

Appendix L:
Traffic Impact Analysis

GATEWAY SOUTH 8 WAREHOUSE

TRAFFIC IMPACT ANALYSIS

SEPTEMBER 29, 2021

PREPARED FOR:

HILLWOOD

901 Via Piemonte, Suite 175
Ontario, California 91764

PREPARED BY:

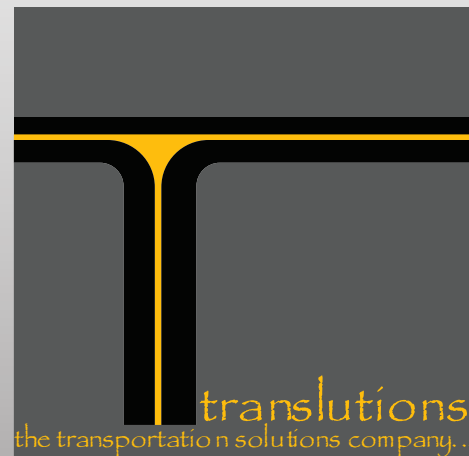

translutions, inc.

17632 Irvine Boulevard, Suite 200
Tustin, California 92780
(949) 656-3131



TABLE OF CONTENTS

1.0 EXECUTIVE SUMMARY	1
1.1 Project Generated VMT	1
1.2 Project Effect on VMT	1
1.3 LOS Analysis Deficiencies and Proposed Improvements.....	1
2.0 INTRODUCTION	2
2.1 Purpose of the Traffic Study and Study Objectives.....	2
2.2 Project Location & Study Area	2
2.3 Analysis Scenarios.....	5
3.0 PROJECT DESCRIPTION	5
3.1 Project Trip Generation	5
3.2 Project Trip Distribution & Assignment.....	5
4.0 LOS DEFINITIONS, PROCEDURES, AND THRESHOLDS	17
4.1 Intersection Levels of Service	17
4.2 Levels of Service Thresholds	17
4.3 Project Deficiencies	17
5.0 VOLUME DEVELOPMENT METHODOLOGY	18
5.1 Existing Traffic Volumes	18
5.2 Opening Year (2023) Base Traffic Volumes	18
5.3 Opening Year (2023) Base plus Other Proposed Projects Traffic Volumes.....	18
5.4 Opening Year (2023) Base plus Other Proposed Projects plus Project Traffic Volumes	18
6.0 EXISTING CONDITIONS	18
6.1 Existing Roadway Conditions.....	18
6.2 Existing Transit Service.....	21
6.3 Existing Bicycle & Pedestrian Facilities.....	21
6.4 Existing Intersection Levels of Service	21
7.0 OPENING YEAR (2023) CONDITIONS	28
7.1 Opening Year (2023) Roadway Conditions	28
7.2 Opening Year (2023) Transit Service	28
7.3 Opening Year (2023) Pedestrian & Bicycle Facilities	28
7.4 Opening Year (2023) Base Intersection Levels of Service.....	28
7.5 Opening Year (2023) Base plus Other Proposed Projects Intersection Levels of Service	28
28	
7.6 Opening Year (2023) Base plus Other Proposed Projects plus Project Intersection	
Levels of Service	28
8.0 CIRCULATION IMPROVEMENTS	36
8.1 Opening Year (2023) Base plus Other Proposed Projects plus Project Conditions.....	36
9.0 VMT ANALYSIS	36
10.0 SUMMARY & CONCLUSIONS	43

APPENDICES

Appendix A: Traffic Counts
 Appendix B: Detailed Volume Development Worksheets
 Appendix C: Level of Service Worksheets
 Appendix D: SBCTA Low VMT Area Screening Tool

FIGURES AND TABLES

FIGURES

Figure 1: Regional Project Location..... 3
 Figure 2: Project Site Plan..... 4
 Figure 3: Study Area Intersections 6
 Figure 4: Project Trip Distribution (Passenger Vehicles) 12
 Figure 5: Project Trip Distribution (Trucks) 13
 Figure 6: Project Trip Assignment (Passenger Vehicles) 14
 Figure 7: Project Trip Assignment (Trucks) 15
 Figure 8: Total Project Trip Assignment 16
 Figure 9: Other Proposed Projects Locations 19
 Figure 10: Transit 22
 Figure 11: Existing Bike Lanes 23
 Figure 12: City of San Bernardino Conceptual Trail System 24
 Figure 13: Pedestrian Sidewalks 25
 Figure 14: Existing Intersection Geometrics and Stop Control 26
 Figure 15: Existing Peak Hour Traffic Volumes 27
 Figure 16: Opening Year (2023) Base Peak Hour Traffic Volumes 30
 Figure 17: Opening Year (2023) Base Plus Other Proposed Projects Peak Hour Traffic Volumes 32
 Figure 18: Opening Year (2023) Base Plus Other Proposed Projects plus Project Intersection Geometrics and Stop Control ... 33
 Figure 19: Opening Year (2023) Base Plus Other Proposed Projects plus Project Peak Hour Traffic Volumes 34
 Figure 20: Opening Year (2023) Base plus Other Proposed Projects plus Project Peak Hour Signal Warrants 37
 Figure 21: Year 2040 With Project Peak Hour Signal Warrants 38
 Figure 22: Opening Year (2023) Base Plus Other Proposed Projects plus Project With Improvements Intersection Geometrics and Stop Control..... 40

TABLES

Table A: Summary of Project Generated VMT 1
 Table B: Summary of Project Effect on VMT 1
 Table C: Project Trip Generation (High-Cube Short Term Transload Warehouse) 7
 Table D: Project Trip Generation (High-Cube Cold Storage Warehouse) 8
 Table E: Total Project Trip Generation Summary (High-Cube Short Term & High-Cube Cold Storage Warehouse) 9
 Table F: Existing Use Trip Generation..... 10
 Table G: Total Net Project Trip Generation Summary 11
 Table H: Intersection LOS Criteria 17
 Table I: Other Proposed Projects Trip Generation..... 20
 Table J: Existing Intersection Levels of Service..... 29
 Table K: Opening Year (2023) Base Intersection Levels of Service..... 31
 Table L: Opening Year (2023) Base plus Other Proposed Projects plus Project Intersection Levels of Service..... 35
 Table M: Opening Year (2023) Base plus Other Proposed Projects plus Project With Improvements Levels of Service 39
 Table N: Project Generated VMT 41
 Table O: Project Effect on VMT 43

1.0 EXECUTIVE SUMMARY

The following Executive Summary includes a summary of the VMT analyses prepared for the proposed Gateway South 8 warehouse development project. A summary of the LOS deficiencies and proposed improvements for the study intersections is also included.

1.1 Project Generated VMT

Table A below summarizes the project generated baseline and year 2040 Vehicle Miles Traveled (VMT) analyses for the proposed project. As shown in Table A, the baseline plus project VMT per service population is 24.4 miles, which is less than the City's General Plan Buildout VMT per service population of 31.6 miles, therefore, the project does not have an VMT impact under baseline plus project conditions. In addition, the year 2040 plus project VMT per service population is 25.4 miles, which is less than the City's General Plan Buildout VMT per service population of 31.6 miles, and therefore, the project does not have an VMT impact under year 2040 plus project conditions.

Table A: Summary of Project Generated VMT

Baseline	Project
OD VMT per service population	24.4
City Threshold**	31.6
Impact Less Than Significant?	Yes
2040	Project
OD VMT per service population	25.4
City Threshold**	31.6
Impact Less Than Significant?	Yes

1.2 Project Effect on VMT

Table B below summarizes the project effect on VMT under baseline and year 2040 conditions for the proposed project. As shown in Table B, the baseline plus project VMT per service population does not increase when compared to the no project condition, therefore, the project does not have an VMT impact under baseline plus project conditions. In addition, the year 2040 plus project VMT per service population does not increase when compared to the no project condition, therefore, the project does not have an VMT impact under year 2040 plus project conditions.

Table B: Summary of Project Effect on VMT

	With Project	Without Project	Difference
Baseline			
VMT per service population	11.010	11.0166	-0.0064
Year 2040			
VMT per service population	12.382	12.3847	-0.0024

1.3 LOS Analysis Deficiencies and Proposed Improvements

The deficient intersections and proposed improvements at the study are intersections are included below.

Existing Conditions

The following intersections currently operate at deficient LOS under existing conditions:

- Lena Road and Orange Show Road (p.m. peak hour).

Opening Year (2023) Base Conditions

The following intersections are forecast to operate at deficient LOS under opening year (2023) base conditions:

- Lena Road and Orange Show Road (p.m. peak hour).

Opening Year (2023) Base plus Other Proposed Projects Conditions

The following intersections are forecast to operate at deficient LOS under opening year (2023) base plus other proposed projects conditions:

- Lena Road and Orange Show Road (p.m. peak hour).

Opening Year (2023) Base plus Other Proposed Projects plus Project Conditions

The following intersections are forecast to operate at deficient LOS under opening year (2023) base plus other proposed projects plus project conditions:

- Lena Road and Orange Show Road (p.m. peak hour).

The following improvements would restore the LOS to acceptable traffic operations:

- Lena Road and Orange Show Road: Installation of an all-way stop control.

2.0 INTRODUCTION

This report presents the methodology, findings and conclusions of the Traffic Impact Analysis (TIA) prepared for the proposed Gateway South 8 warehouse development project. The proposed project site is at the northwest corner of the intersection of Lena Road and Norman Road in the City of San Bernardino. The project proposes the construction of approximately 304,558 square feet of high-cube warehousing uses.

2.1 Purpose of the Traffic Study and Study Objectives

This report is intended to satisfy the requirements for a TIA established by the City of San Bernardino *Traffic Impact Analysis Guidelines* August 2020 (Guidelines) and the San Bernardino County Congestion Management Program (CMP), adopted November 3, 1993, and last revised in 2016. The San Bernardino County CMP is implemented by the San Bernardino County Transportation Authority (SBCTA, previously San Bernardino Associated Governments). The City has adopted vehicle LOS policies that set standards for which local agency infrastructure will strive to maintain. These policies are contained in the General Plan and apply to discretionary approvals of new land use and transportation projects.

The City guidelines require analysis of off-site intersections potentially affected by the project, which the City defines as intersections at which the project is forecast to add 50 or more peak hour trips (two-way). This report evaluates seven intersections and project driveways under four analysis scenarios and proposes circulation improvements for intersections that operate or are forecast to operate at unsatisfactory levels of service. In addition, this reports also evaluates alternative modes of travel in the vicinity of the project.

2.2 Project Location & Study Area

As stated earlier, the project is located at the northwest corner of the intersection of Lena Road and Norman Road in the City of San Bernardino. Figure 1 shows the regional location of the project. The project proposes 304,558 square feet of high-cube warehouse uses. The project opening year is 2023. Figure 2 illustrates the site plan of the proposed project.

Based on the trip generation and trip distribution of the proposed project, and based on discussion with City staff, this report analyzes the following intersections for traffic operations:

1. Foisy Street and Driveway 1.
2. Foisy Street and Norman Road.
3. Driveway 2 and Norman Road.



FIGURE 1

Legend
 Project Boundary

**Gateway South 8 Warehouse
 Regional Project Location**



PROPERTY OWNER
 HILLWOOD INVESTMENT PROPERTIES
 901 VIA MEMORIE, SUITE 175
 OAKLAND, CA 94764
 PHONE: 949-882-8793

APPLICANT
 HILLWOOD INVESTMENT PROPERTIES
 901 VIA MEMORIE, SUITE 175
 OAKLAND, CA 94764
 PHONE: 949-882-8793

APPLICANT'S REPRESENTATIVE
 FPA INC.
 18031 BARDEN AVENUE, SUITE 1100
 IRVINE, CA 92612
 TEL: 949-261-2700
 FAX: 949-261-2851

ADDRESS OF THE PROPERTY
 NW CORNER OF NORMAN ROAD AND LENA ROAD

ASSESSOR'S PARCEL NUMBER
 0280-191-27, 28
 0280-191-29, 30 THROUGH 16, 30
 0280-17-01 THROUGH 11

ZONING
 GENERAL PLAN DESIGNATION: INDUSTRIAL
 ZONING DESIGNATION: "L" INDUSTRIAL LIGHT

- SITE PLAN KEYNOTES**
- HEAVY BROOM FINISH CONC. PAVEMENT.
 - ASPHALT CONCRETE (AC) PAVING
 - CONCRETE WALKWAY
 - DRIVEWAY APPROX TO BE CONSTRUCTED PER "L" DRAWINGS.
 - 6" - 8" (6" MIN. THICK CONCRETE EXTERIOR LANDING PAD TOP AT ALL EXTERIOR MAIN DOORS TO LANDSCAPED AREAS. FRESH TO BE MEDIAL BROOM FINISH.
 - DOCK DOORS TO BE 1/4" AC W/ CRANE WAY W/ 100 LB. ROLLER BEARING CITY REGISTRATION.
 - IF N PROVIDE METAL MANUAL OPERATED GATES W/ 2000-LB PAD LOCK PER FIRE DEPARTMENT STANDARDS FOR DRIVEWAY.
 - EXTERIOR CONC. STAIR.
 - LANDSCAPE. SEE "L" DWGS.
 - CONCRETE TILT-UP SCREEN WALL.
 - BIKE RACK.
 - APPROXIMATE LOCATION OF TRANSFORMER.
 - 1/4" CONCRETE TILT UP SCREEN WALL.
 - TRENCH ENCLOSURE PER CITY STANDARD.
- SITE LEGEND**
- LANDSCAPED AREA
 - STANDARD PARKING STALL (9' X 19')
 - AC. PAVING - SEE "C" DWGS. FOR THICKNESS
 - HANDICAP PARKING STALL (9' X 19')
 - CONCRETE FINISH FOR THICKNESS
 - PROPERTY LINE

PROJECT DATA

	BLDG 8	BLDG 9
SITE AREA	In s.f. 522,294 s.f.	141,108 s.f.
	In acres 12.01 acres	3.24 acres
BUILDING AREA		
Ground Office	10,000 s.f.	6,000 s.f.
Warehouse	298,598 s.f.	
TOTAL	308,598 s.f.	
COVERAGE	59.2%	
AUTO PARKING REQUIRED	244 stalls	
AUTO PARKING PROVIDED		
Standard (9' x 19')	180 stalls	
Disabled	39	
Trailer Parking	47 stalls	
TOTAL	248 stalls	
MAXIMUM FLOOR AREA RATIO		
FAR - 75%		
MINIMUM CLEARANCE FOR CITY:		
Zone - Industrial Light (L)		
MAXIMUM BUILDING HEIGHT ALLOWED		
Height - 50'		
SETBACKS		
Lena Rd - 20'		
S. Foisy - 10'		
Norman Rd - 10'		
Rear/Side - 10'		

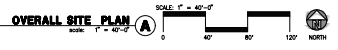
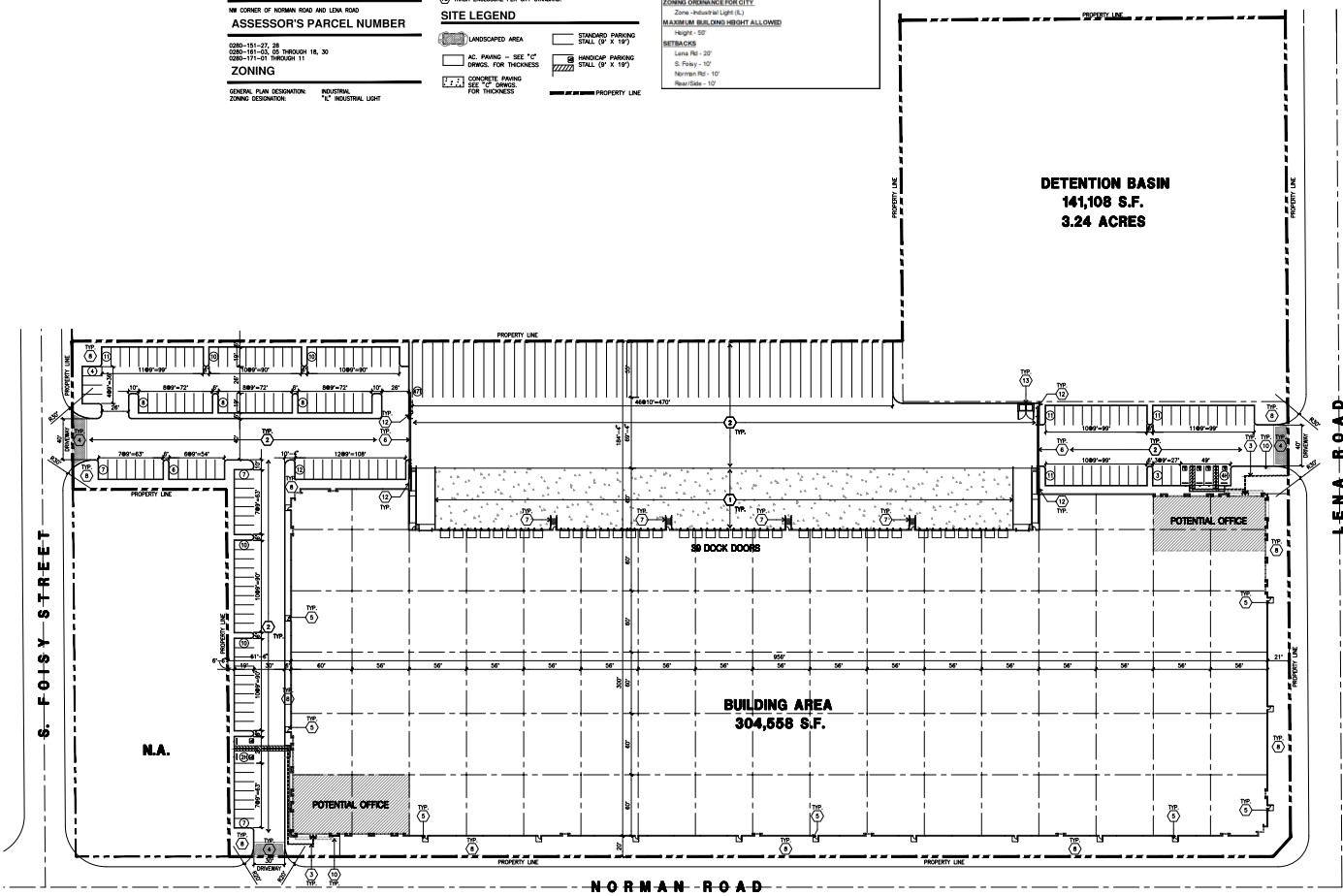
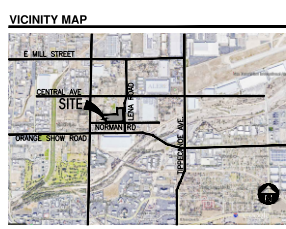

HPA architecture
 FPA, INC.
 18031 BARDEN AVENUE, SUITE 1100
 IRVINE, CA 92612
 TEL: 949-261-2700
 FAX: 949-261-2851
 email: fpa@hpa.com

Owner:
 HILLWOOD
 a PERKINS COMPANY
 901 Via Memorie, Suite 175
 Oakland, CA 94764
 tel: (909) 882-0033
 fax: (909) 882-0073

Project:
 GATEWAY SOUTH BUILDING 8
 SAN BERNARDINO, CA

Consultants:
 CIVIL Thienes Eng.
 STRUCTURAL
 MECHANICAL
 PLUMBING
 ELECTRICAL Hunter Landiscape
 LANDSCAPE
 FIRE PROTECTION
 SOLID NUMBER

Title: OVERALL SITE PLAN

Project Number: 21201
 Drawn by: KT
 Date: 6/11/2021
 Revision:

Sheet:
 DAB-A1.1

FIGURE 1

Gateway South 8 Warehouse Site Plan



4. Lena Road and Central Avenue.
5. Lena Road and Driveway 3.
6. Lena Road and Norman Road.
7. Lena Road and Orange Show Road. and

Figure 3 illustrates intersections included in the TIA.

2.3 Analysis Scenarios

Based on the City guidelines, this report analyzes traffic conditions for the following scenarios:

1. Existing Conditions,
2. Opening Year (2023) Base Conditions,
3. Opening Year (2023) Base plus Other Projects Conditions. and
4. Opening Year (2023) Base plus Other Projects plus Project Conditions.

Consistent with City guidelines, this report analyzes weekday a.m. and p.m. peak hour conditions. The a.m. peak hour is defined as the one hour of highest traffic volumes occurring between 7:00 and 9:00 a.m. The p.m. peak hour is defined as the one hour of highest traffic volumes occurring between 4:00 and 6:00 p.m.

3.0 PROJECT DESCRIPTION

The project proposes the construction of approximately 304,558 square feet of high-cube warehouse uses on approximately 12.01 acres. Access to the project will be provided via three driveways. The driveways will provide full-access ingress/egress to the project.

3.1 Project Trip Generation

The trip generation for the proposed project was developed based on rates from the Institute of Traffic Engineers' (ITE) *Trip Generation Manual* (10th Edition) for Land Use 154 "High-Cube Transload and Short-Term Storage Warehouse" and Land Use 157 "High-Cube Cold Storage Warehouse". Traffic generated by warehousing projects is further classified into automobile and truck traffic. Based on discussion with City staff, the ITE *Trip Generation Manual* (10th Edition Supplement) weighted average rates were used to determine the truck traffic as a percent of the total traffic. In addition, the trucks were further classified based on axle type using the Fontana Truck Trip Generation Study (August 2003). The truck trips were converted to Passenger Car Equivalents using the City of San Bernardino conversion rates of 2.0 for 2-axle trucks, 2.5 for 3-axle trucks, and 3.0 for 4 axle trucks. The project site includes an existing auto body shop. The trips from the auto body were subtracted from the proposed high-cube warehouse trips to develop the total net project trip generation. The trip generation for the auto body shop is based on rates for Land Use "Automobile Care Center" from the ITE Trip Generation Manual. The project trip generation is included in Tables C, D, E, F, and G. Table C includes the trip generation of the proposed 243,646 square foot High-Cube Transload and Short-Term Storage use. Table D includes the trip generation for the proposed 60,912 square foot High-Cube Cold Storage use. Table E includes the total trip generation for both the proposed High-Cube Transload and Short-Term Cold Storage uses. Table F includes the trip generation for the existing 4,500 square foot auto body shop. Table G includes the total net project trip generation. The total net project trip generation is 27 a.m. peak hour PCE trips, 22 p.m. peak hour PCE trips, and 553 daily PCE trips.

3.2 Project Trip Distribution & Assignment

Project trip distribution patterns for the proposed project were developed separately for autos and trucks based on location of local and regional destinations. The project trip generation was applied to the trip distribution patterns for the project to develop trip assignments for new project trips. Figure 4 shows the trip distribution for passenger vehicles and Figure 5 shows the trip distribution for trucks. Figure 6 shows the trip assignment for passenger vehicles and Figure 7 shows the trip assignment for trucks. The total project trip assignment is shown in Figure 8.



FIGURE 3

Gateway South 8 Warehouse
Study Area Intersections

Legend

- Project Boundary
- Study Area Intersections

translutions
the transportation solutions company...

Table C: Project Trip Generation (High-Cube Short Term Transload Warehouse)

Land Use	Units	Peak Hour						Daily
		AM Peak Hour			PM Peak Hour			
		In	Out	Total	In	Out	Total	
Total Vehicle Rates								
Trip Generation Rates ¹	TSF	0.062	0.018	0.080	0.028	0.072	0.100	1.400
PCE Inbound/Outbound Splits		77%	23%	100%	28%	72%	100%	100%
Passenger Car Equivalent Rates Calculations								
Passenger Cars								
Recommended Mix (%) ²		84.09%	44.57%	75.00%	83.21%	92.64%	90.00%	84.29%
PCE Factor ³		1.0	1.0	1.0	1.0	1.0	1.0	1.0
PCE Rates		0.052	0.008	0.060	0.023	0.067	0.090	1.180
2-Axle Trucks								
Recommended Mix (%) ²		2.69%	9.39%	4.23%	2.84%	1.25%	1.69%	2.66%
PCE Factor ³		2.0	2.0	2.0	2.0	2.0	2.0	2.0
PCE Rates		0.003	0.003	0.007	0.002	0.002	0.003	0.075
3-Axle Trucks								
Recommended Mix (%) ²		3.61%	12.59%	5.68%	3.81%	1.67%	2.27%	3.57%
PCE Factor ³		2.5	2.5	2.5	2.5	2.5	2.5	2.5
PCE Rates		0.006	0.006	0.011	0.003	0.003	0.006	0.125
4-Axle Trucks								
Recommended Mix (%) ²		9.60%	33.46%	15.09%	10.13%	4.44%	6.04%	9.48%
PCE Factor ³		3.0	3.0	3.0	3.0	3.0	3.0	3.0
PCE Rates		0.018	0.018	0.036	0.009	0.010	0.018	0.398
Warehouse Net PCE Rate		0.078	0.036	0.114	0.036	0.081	0.117	1.778
Total Project Trip Generation (Trips, By Vehicle Type)								
Warehouse	243.646	TSF						
Passenger Cars			13	2	15	6	16	22
2-Axle Trucks			1	0	1	0	0	0
3-Axle Trucks			0	1	1	1	0	1
4+ Axle Trucks			2	1	3	0	1	1
All Trucks			3	2	5	1	1	2
Total Vehicles			16	4	20	7	17	24
Total Project Trip Generation (Passenger Car Equivalent Trips, By Vehicle Type)								
Passenger Cars			13	2	15	6	16	22
Truck PCE								
2-Axle Trucks			2	0	2	0	0	0
3-Axle Trucks			0	3	3	3	0	3
4+ Axle Trucks			6	3	9	0	3	3
Total Truck PCE			8	6	14	3	3	6
Total PCE			21	8	29	9	19	28

¹ Rates based on Land Use 154 - "High-Cube Transload and Short-Term Storage Warehouse" from Institute of Transportation Engineers (ITE) Trip Generation (10th Ed.+Supplement).

² Truck percentage per ITE 10th Edition (Supplement) with truck type breakdown based on the 2003 Fontana Truck Study.

³ PCE Factor per *City of San Bernardino Transportation Impact Analysis Preparation Guide for Vehicle Miles Traveled and Level of Service Assessment*.

Table D: Project Trip Generation (High-Cube Cold Storage Warehouse)

Land Use	Units	Peak Hour						Daily
		AM Peak Hour			PM Peak Hour			
		In	Out	Total	In	Out	Total	
Total Vehicle Rates								
Trip Generation Rates ¹	TSF	0.089	0.021	0.110	0.047	0.073	0.120	2.120
PCE Inbound/Outbound Splits		81%	19%	100%	39%	61%	100%	100%
Passenger Car Equivalent Rates Calculations								
Passenger Cars								
Recommended Mix (%) ²		83.16%	28.23%	72.73%	70.51%	77.87%	75.00%	64.62%
PCE Factor ³		1.0	1.0	1.0	1.0	1.0	1.0	1.0
PCE Rates		0.074	0.006	0.080	0.033	0.057	0.090	1.370
2-Axle Trucks								
Recommended Mix (%) ²		2.85%	12.15%	4.62%	4.99%	3.75%	4.23%	5.99%
PCE Factor ³		2.0	2.0	2.0	2.0	2.0	2.0	2.0
PCE Rates		0.005	0.005	0.010	0.005	0.005	0.010	0.254
3-Axle Trucks								
Recommended Mix (%) ²		3.82%	16.30%	6.19%	6.70%	5.03%	5.68%	8.03%
PCE Factor ³		2.5	2.5	2.5	2.5	2.5	2.5	2.5
PCE Rates		0.009	0.009	0.017	0.008	0.009	0.017	0.426
4-Axle Trucks								
Recommended Mix (%) ²		10.16%	43.32%	16.46%	17.80%	13.36%	15.09%	21.35%
PCE Factor ³		3.0	3.0	3.0	3.0	3.0	3.0	3.0
PCE Rates		0.027	0.027	0.054	0.025	0.029	0.054	1.358
Warehouse Net PCE Rate		0.115	0.047	0.162	0.070	0.101	0.172	3.408
Total Project Trip Generation (Trips, By Vehicle Type)								
Warehouse	60.912	TSF						
Passenger Cars			5	0	5	2	3	5
2-Axle Trucks			0	0	0	0	0	0
3-Axle Trucks			0	0	0	0	0	0
4+ Axle Trucks			0	1	1	0	1	1
All Trucks			0	1	1	0	1	1
Total Vehicles			5	1	6	2	4	6
Total Project Trip Generation (Passenger Car Equivalent Trips, By Vehicle Type)								
Passenger Cars			5	0	5	2	3	5
Truck PCE								
2-Axle Trucks			0	0	0	0	0	0
3-Axle Trucks			0	0	0	0	0	0
4+ Axle Trucks			0	3	3	0	3	3
Total Truck PCE			0	3	3	0	3	3
Total PCE			5	3	8	2	6	8

¹ Rates based on Land Use 157 - "High-Cube Cold Storage Warehouse" from Institute of Transportation Engineers (ITE) Trip Generation (10th Ed.+Supplement).

² Truck percentage per ITE 10th Edition (Supplement) with truck type breakdown based on the 2003 Fontana Truck Study.

³ PCE Factor per *City of San Bernardino Transportation Impact Analysis Preparation Guide for Vehicle Miles Traveled and Level of Service Assessment*.

Table E: Total Project Trip Generation Summary (High-Cube Short Term & High-Cube Cold Storage Warehouse)

Land Use	Units	Peak Hour						Daily
		AM Peak Hour			PM Peak Hour			
		In	Out	Total	In	Out	Total	
Total Project Trip Generation (Trips, By Vehicle Type)								
High Cube & Cold Storage	304.558	TSF						
Passenger Cars			18	2	20	8	19	27
2-Axle Trucks			1	0	1	0	0	0
3-Axle Trucks			0	1	1	1	0	1
4+ Axle Trucks			2	2	4	0	2	2
All Trucks			3	3	6	1	2	3
Total Vehicles			21	5	26	9	21	30
Total Project Trip Generation (Passenger Car Equivalent Trips, By Vehicle Type)								
Passenger Cars			18	2	20	8	19	27
Truck PCE								
2-Axle Trucks			2	0	2	0	0	0
3-Axle Trucks			0	3	3	3	0	3
4+ Axle Trucks			6	6	12	0	6	6
Total Truck PCE			8	9	17	3	6	9
Total PCE			26	11	37	11	25	36

Table F: Existing Use Trip Generation

Land Use	Units ¹	Peak Hours						Daily
		AM Peak Hour			PM Peak Hour			
		In	Out	Total	In	Out	Total	
Body Shop	4.5 TSF							
Trip Generation Rates ²		1.49	0.77	2.25	1.49	1.62	3.11	19.32
PCE Inbound/Outbound Splits		7	3	10	7	7	14	87
Total Trip Generation		7	3	10	7	7	14	87

¹ TSF=Thousand Square Feet

² Trip generation based on rates for Land Use 942 - "Automobile Care Center" from Institute of Transportation Engineers' (ITE) Trip Generation (10th Edition).

Table G: Total Net Project Trip Generation Summary

Land Use	Units	Peak Hour						Daily
		AM Peak Hour			PM Peak Hour			
		In	Out	Total	In	Out	Total	
Total Project Trip Generation (Trips, By Vehicle Type)								
Proposed High Cube & Cold Storage	304.558	TSF						
Passenger Cars			18	2	20	8	19	27
Truck PCE								
2-Axle Trucks			2	0	2	0	0	0
3-Axle Trucks			0	3	3	3	0	3
4+ Axle Trucks			6	6	12	0	6	6
Total Truck PCE			8	9	17	3	6	9
Total PCE			26	11	37	11	25	36
Existing Body Shop	4.500	TSF	7	3	10	7	7	14
Total Net PCE			19	8	27	4	18	22

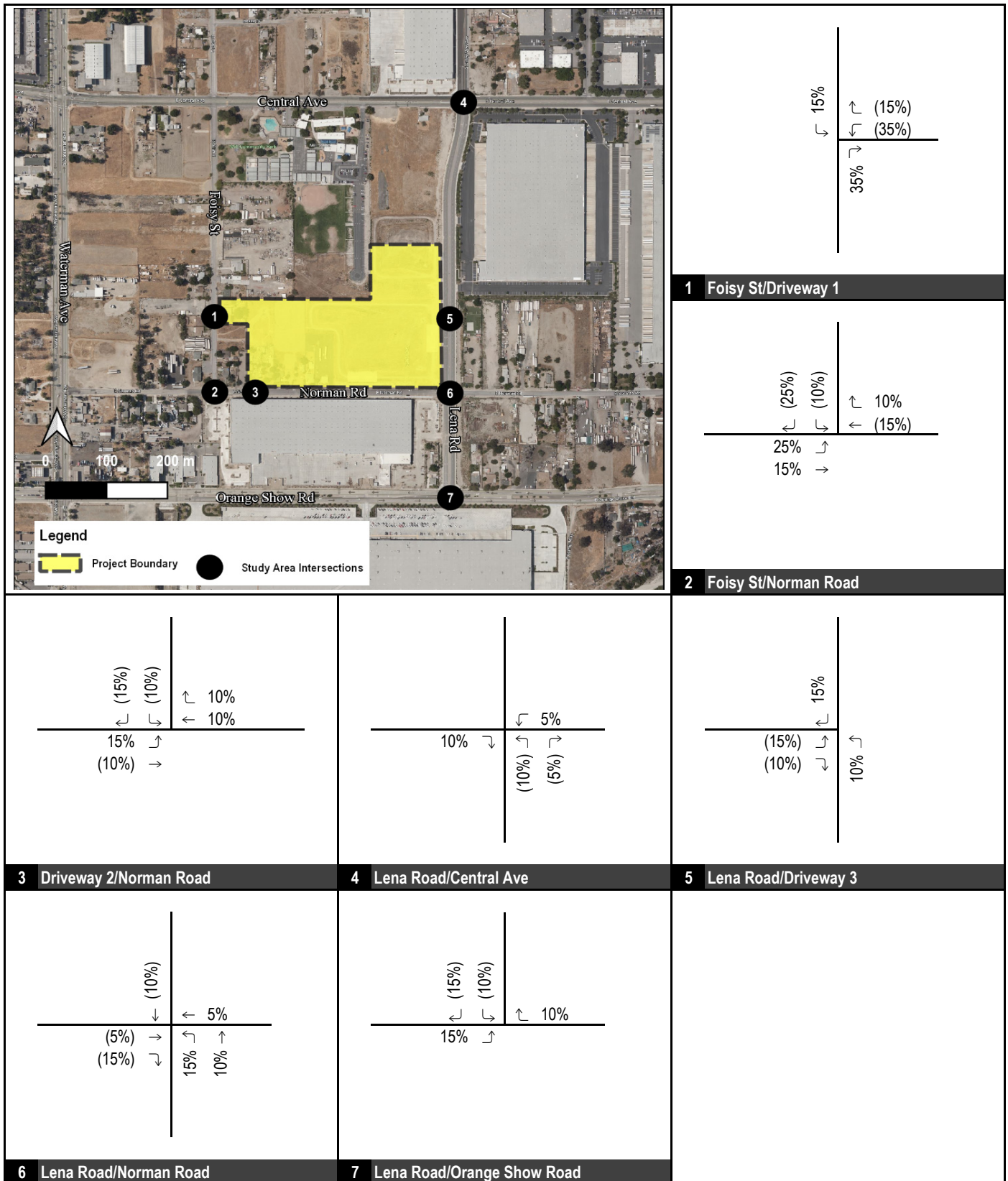

FIGURE 4

XXX%(YYY%) Inbound%(Outbound%) Percent



**Gateway South 8 Warehouse
 Project Trip Distribution (Autos)**

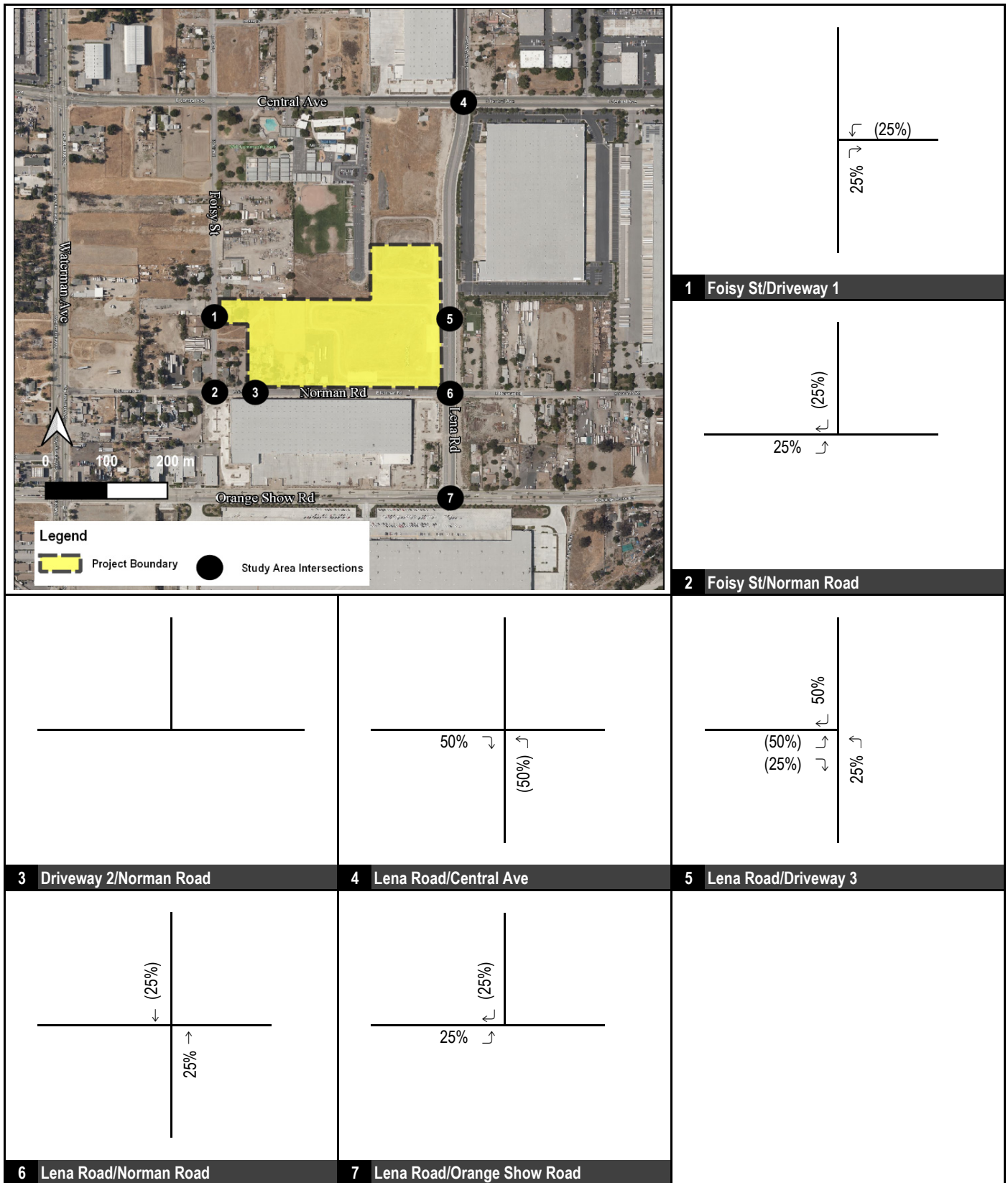

FIGURE 5

XXX%(YYY%) Inbound%(Outbound%) Percent



**Gateway South 8 Warehouse
Project Trip Distribution (Trucks)**

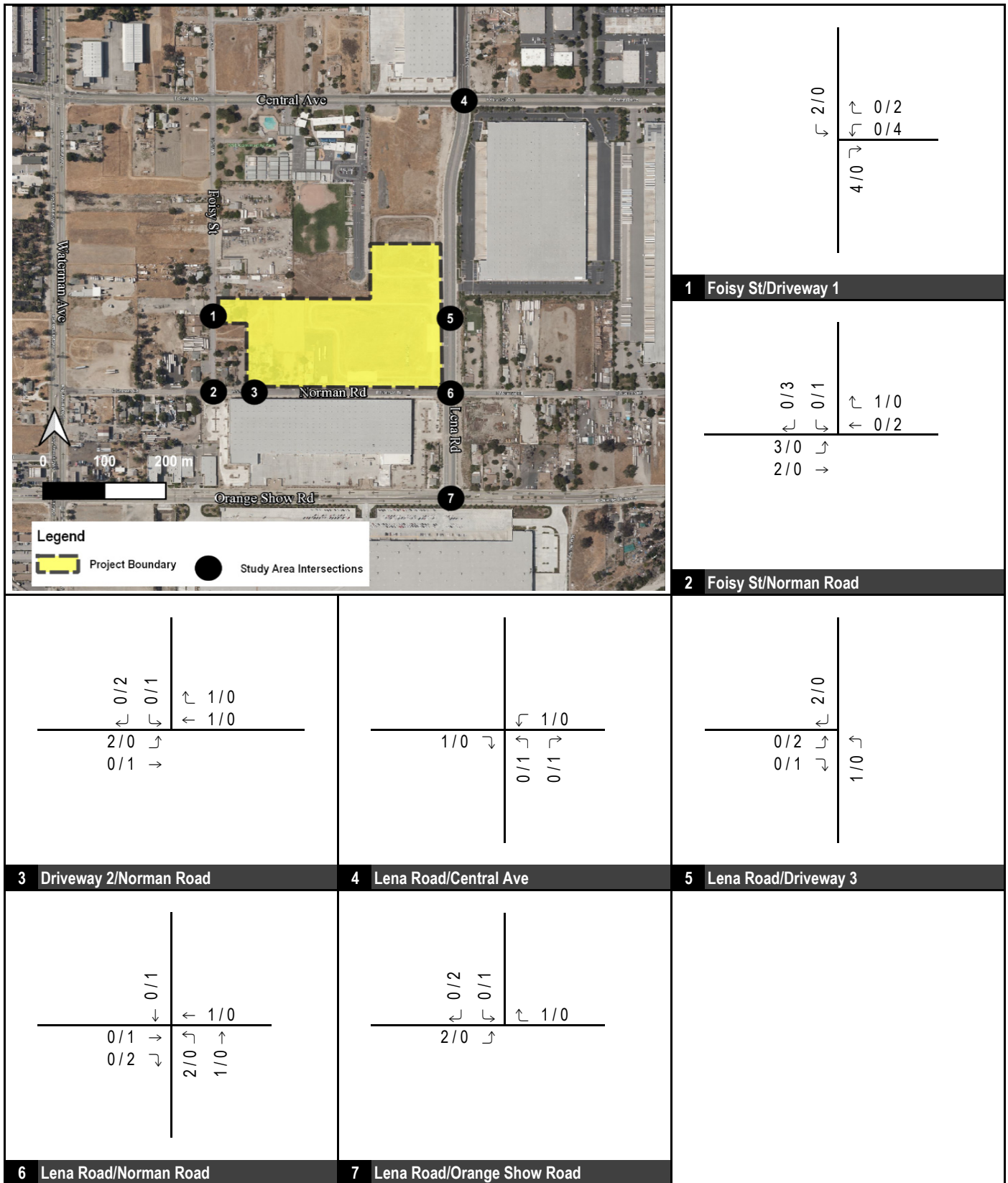

FIGURE 6

XXX / YYY AM / PM Peak Hour Trips



**Gateway South 8 Warehouse
Project Trip Assignment (Autos)**

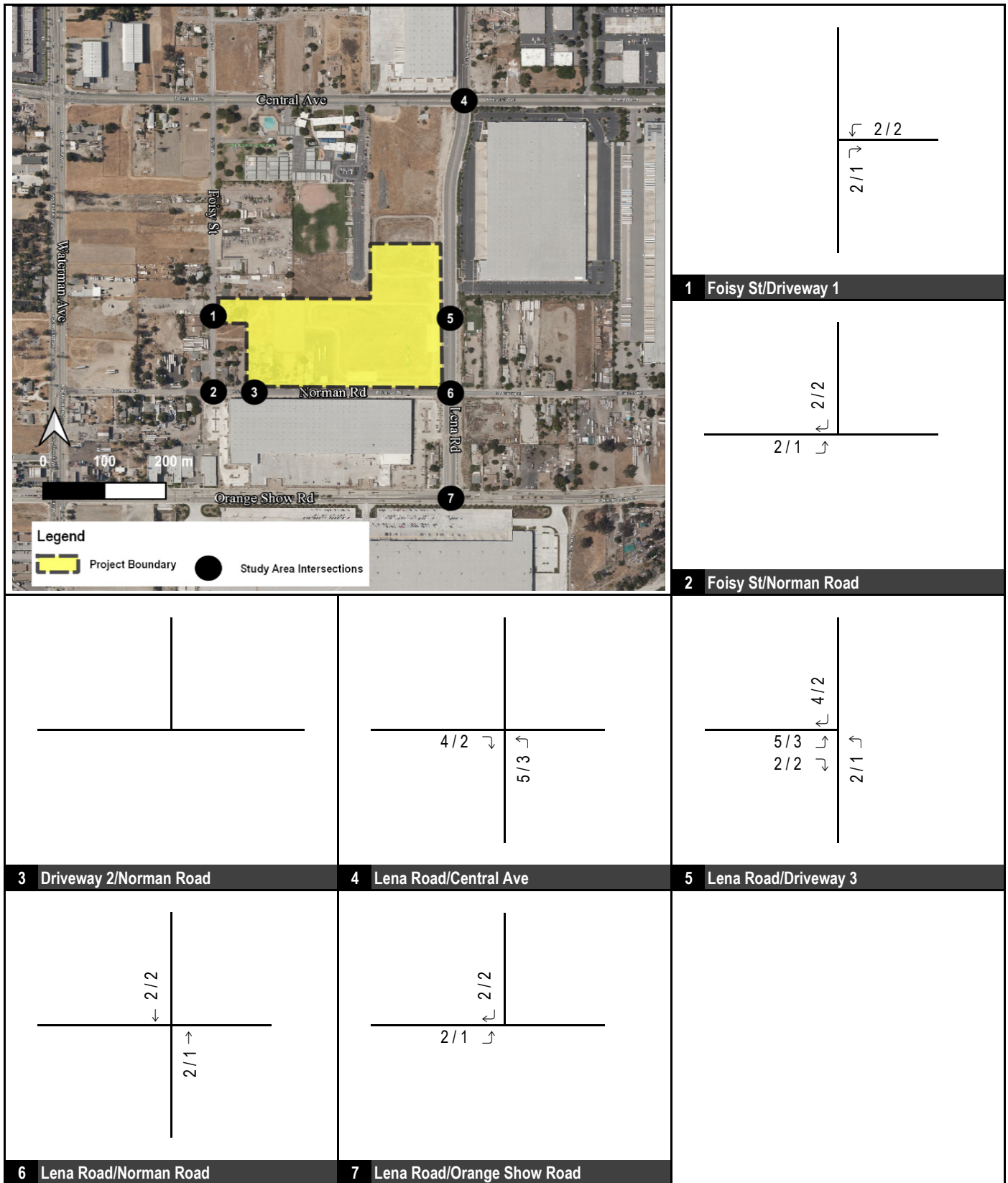

FIGURE 7

XXX / YYY AM / PM Peak Hour Trips



**Gateway South 8 Warehouse
Project Trip Assignment (Trucks)**

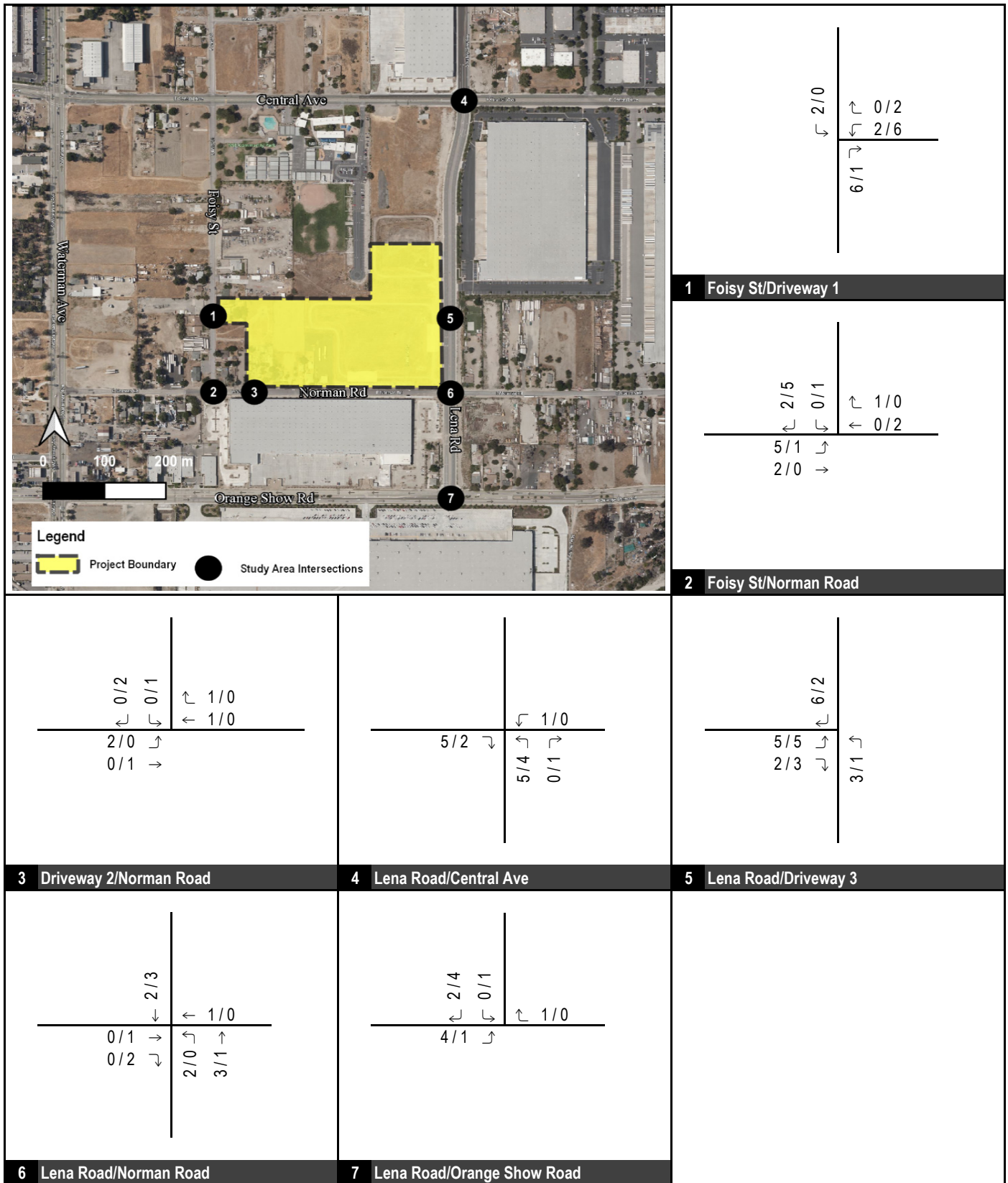

FIGURE 8

XXX / YYY AM / PM Peak Hour Trips



**Gateway South 8 Warehouse
 Total Project Trip Assignment**

4.0 LOS DEFINITIONS, PROCEDURES, AND THRESHOLDS

Level of service (LOS) is a measure of the quality of operational conditions within a traffic stream and is generally expressed in terms of such measures as speed and travel time, freedom to maneuver, traffic interruptions, and comfort and convenience. Levels range from A to F, with LOS A representing excellent (free-flow) conditions and LOS F representing extreme congestion. Consistent to the guidelines, the Highway Capacity Manual (HCM) procedures have been used to evaluate levels of service. This section discusses the LOS definitions, procedures, and thresholds used in this report.

4.1 Intersection Levels of Service

The analysis of traffic operations at intersections was conducted according to the Highway Capacity Manual 6th Edition (HCM) delay methodologies, which is described in the Highway Capacity Manual (Transportation Research Board, Washington, D.C., November 2016). Under the HCM methodology, LOS for signalized intersections is based on the average delay experienced by vehicles traveling through an intersection, whereas for unsignalized intersections, the LOS is based on the worst approach where the minor leg has a shared lane and on the worst movement where the minor leg has dedicated turn lanes. Table H presents a brief description of each level of service letter grade, as well as the range of delays associated with each grade.

4.2 Levels of Service Thresholds

The City of San Bernardino uses LOS D as the minimum level of service standard for intersection operations. Therefore, study intersections operating at LOS E, or F are required to be mitigated to provide LOS conformity with the City's General Plan goals.

Table H: Intersection LOS Criteria

LOS	Description of Drivers' Perception and Traffic Operation	Delay in Seconds	
		Unsignalized	Signalized
A	This level is typically assigned when the volume-to-capacity ratio is low and either progression is exceptionally favorable, or the cycle length is very short. If it is due to favorable progression, most vehicles arrive during the green indication and travel through the intersection without stopping.	≤ 10	≤ 10
B	This level is assigned when the volume-to-capacity ratio is low and either progression is highly favorable, or the cycle length is short. More vehicles stop than with LOS A.	> 10 and ≤ 15	> 10 and ≤ 20
C	This level is typically assigned when progression is favorable, or the cycle length is moderate. Individual cycle failures (i.e., one or more queued vehicles are not able to depart as a result of insufficient capacity during the cycle) may begin to appear at this level. The number of vehicles stopping is significant, although many vehicles still pass through the intersection without stopping.	> 15 and ≤ 25	> 20 and ≤ 35
D	This level is typically assigned when the volume-to-capacity ratio is high and either progression is ineffective, or the cycle length is long. Many vehicles stop and individual cycle failures are noticeable.	> 25 and ≤ 35	> 35 and ≤ 55
E	This level is typically assigned when the volume-to-capacity ratio is high, progression is unfavorable, and the cycle length is long. Individual cycle failures are frequent.	> 35 and ≤ 50	> 55 and ≤ 80
F	This level is typically assigned when the volume-to-capacity ratio is very high, progression is very poor, and the cycle length is long. Most cycles fail to clear the queue.	> 50	> 80

Source: *Highway Capacity Manual, 6th Edition*

4.3 Project Deficiencies

The City Guidelines include project deficiencies for intersection operations. Based on the guidelines, intersections are considered to be deficient when any of the following changes in the volume to capacity ratios occur between the without and with project conditions:

- LOS C: > 0.04
- LOS D: > 0.02
- LOS E, F: > 0.01

5.0 VOLUME DEVELOPMENT METHODOLOGY

Forecast traffic volumes at study intersections were developed based on discussion with City staff and consistent with the guidelines in the CMP. This section discusses the volume development methodology used to forecast future traffic volumes.

5.1 Existing Traffic Volumes

Existing traffic volumes are based on peak hour intersection turn movement counts collected by Counts Unlimited Inc. in June 2021. Vehicle classification counts (e.g., passenger vehicle, 2-axle truck, 3-axle truck, and 4 or more axle truck), were conducted at all existing study area intersections. Consistent with the City guidelines, PCE volumes at these intersections were calculated using a PCE factor of 2.0 for 2-axle trucks, 2.5 for 3-axle trucks, and 3.0 for trucks with 4 or more axles. Detailed volume development worksheets are included in Appendix B.

5.2 Opening Year (2023) Base Traffic Volumes

Opening year (2023) base peak hour traffic volumes were developed by applying an annual growth rate of 3 percent per year (2021 to 2023) to the existing traffic volumes at each study intersection. Detailed volume development worksheets are included in Appendix B.

5.3 Opening Year (2023) Base plus Other Proposed Projects Traffic Volumes

Opening year (2023) base plus other proposed projects peak hour traffic volumes were developed by adding project trips from other proposed projects to the opening year (2023) base traffic volumes. Figure 9 shows the locations of the other proposed projects. Table I lists the other proposed projects included in the analysis. The other proposed projects are anticipated to generate 411 a.m. peak hour trips, 442 p.m. peak hour trips, and 8,594 daily trips. Detailed volume development worksheets are included in Appendix B.

5.4 Opening Year (2023) Base plus Other Proposed Projects plus Project Traffic Volumes

Traffic volumes for opening year (2023) base plus Other Proposed Projects plus Project were developed by adding the trip assignment to the opening year (2023) base plus Other Proposed Projects peak hour traffic volumes.

6.0 EXISTING CONDITIONS

This section discusses the existing transportation conditions in the study area.



6.1 Existing Roadway Conditions

Regional access to the project site is provided by Interstate 10 to the south and west, and State Route 210 to the north and Interstate 15 to the east. Local access is provided by the following roadways:

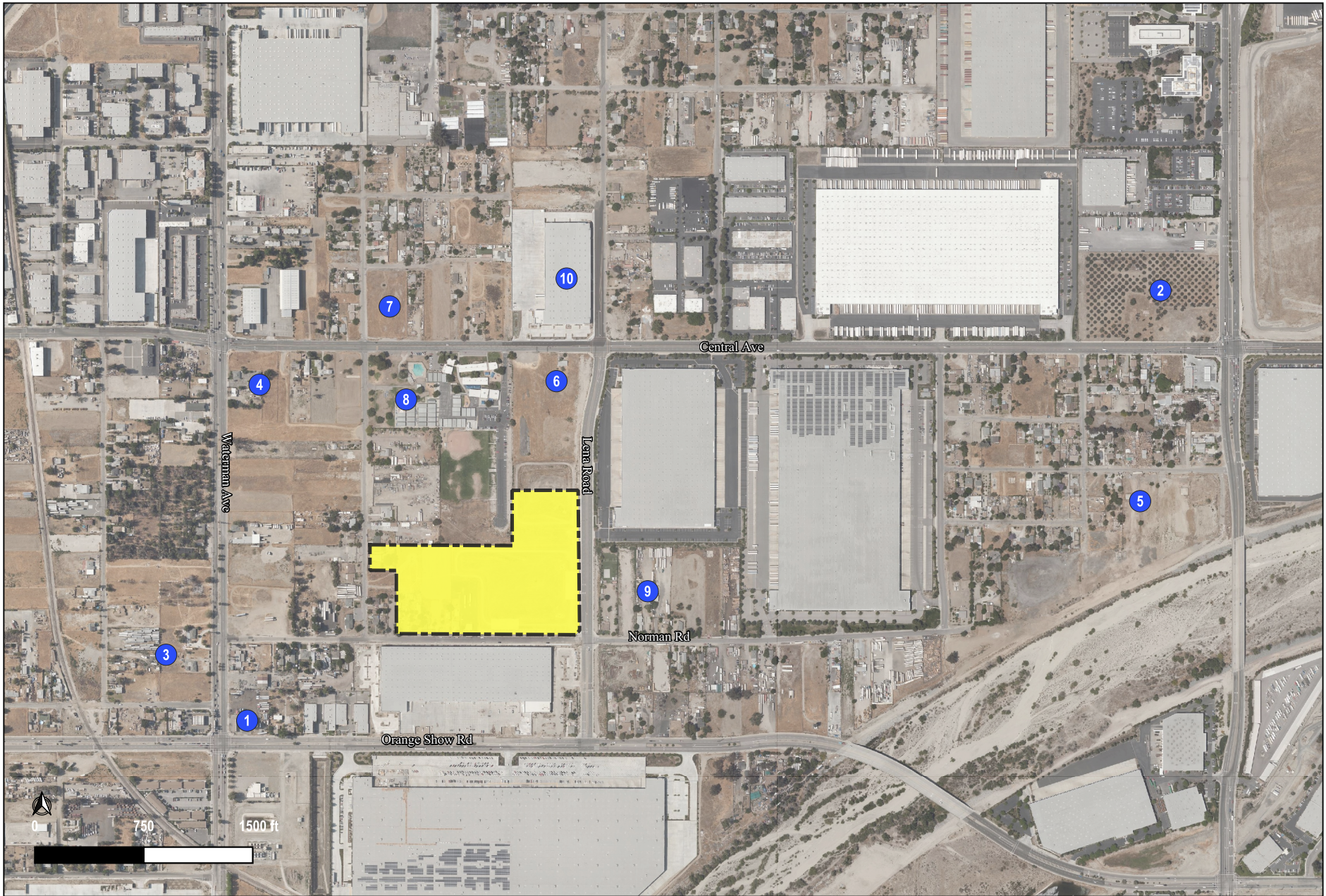
- **Central Avenue** is oriented in the east-west direction and is a four-lane roadway. There is a raised median on Central Avenue from Lena Road to Foisy Street. There is a two-way left-turn lane on Central Avenue from Lena Road to Tippecanoe Avenue. On-street parking is prohibited. The speed limit on Central Avenue is 40 miles per hour. There are no existing bike lanes on Central Avenue. Central Avenue is classified as a Secondary Arterial in the City's General Plan.
- **Lena Road** is oriented in the north-south direction and is a four-lane roadway. There is a two-way left-turn lane on Lena Road from Central Avenue to Norman Road. On-street parking is prohibited. There are no existing bike lanes on Lena Road. There is no posted speed limit on Lena Road. Lena Road is classified as a Major Arterial in the City's General Plan.
- **Orange Show Road** is oriented in the east-west direction and is a four-lane roadway. There is a raised median on Orange Show Road from Lena Road to Waterman Avenue. On-street parking is permitted. The speed limit on Orange Show Road is 50 miles per hour. There are no existing bike lanes on Orange Show Road. Orange Show Road is classified as a Major Arterial in the City's General Plan.
- **Norman Road** is oriented in the east-west direction and is a two-lane roadway. There are no raised medians or two-left-turn lanes on Norman Road. On-street parking is prohibited. There is no posted speed limit on Norman



Legend

 Project Boundary  Other Proposed Projects

 **translutions**
the transportation solutions company...

FIGURE 9

**Gateway South 7 Warehouse
Other Proposed Project Locations**

Table I: Other Proposed Projects Trip Generation

Project Number	Location	Land Use	Quantity	Units	A.M. Peak Hour			P.M. Peak Hour			Daily							
					In	Out	Total	In	Out	Total								
1	1195 S. Waterman Ave	Gasoline Station w/Convenience Market ¹	18	FP	10.14	10.14	20.27	7.81	7.81	15.61	198.16							
		Trip Generation Rates										182	182	365	140	140	281	3,567
		Trip Generation										(113)	(113)	(226)	(79)	(79)	(157)	(384)
		Pass-By Trips										69	69	139	62	62	124	3,183
2	NWC Central Ave/Tippecanoe Ave	Gasoline Station w/Convenience Market ¹	8	FP	10.14	10.14	20.27	7.81	7.81	15.61	198.16							
		Trip Generation Rates										81	81	162	62	62	125	1,585
		Trip Generation										(50)	(50)	(101)	(35)	(35)	(70)	(170)
		Pass-By Trips										31	31	62	27	27	55	1,415
		Total Net Trip Generation	7	TSF	15.06	10.04	25.10	14.17	14.17	28.34	346.23							
		Fast-Food Restaurant ²										104	69	173	98	98	196	2,389
		Trip Generation Rates										(42)	(42)	(85)	(49)	(49)	(98)	(183)
		Trip Generation										61	27	88	49	49	98	2,206
3	NWC of Waterman Ave/Ennis St	Warehousing ³	343	TSF	18	3	21	8	23	31	405							
		Trip Generation (Passenger Cars)										8	11	19	16	26	42	207
		Trip Generation (Truck PCEs)										4	SEC Waterman Ave/Central Ave	Warehousing ⁴	198	TSF	24	6
Trip Generation (Passenger Cars)	8	3	11	8	9	17	324											
Trip Generation (Truck PCEs)	5	SEC Benedict Rd/Sunnyside Ave	Warehousing ⁴	173	TSF	21	5	26	7	21	28	197						
Trip Generation (Passenger Cars)			8										3	11	5	9	14	285
Trip Generation (Truck PCEs)	6	SWC Central Ave/Lena Rd	Warehousing ⁵										135	TSF	14	5	19	6
Trip Generation (Passenger Cars)			8	8	16	5	14	19	136									
Trip Generation (Truck PCEs)	7	NEC Foisy St/Central Ave	Warehousing ⁴	3	TSF	0	0	0	1	0	1	4						
Trip Generation (Passenger Cars)			0										0	0	0	0	0	3
Trip Generation (Truck PCEs)			8										SEC Foisy St/Central Ave	Warehousing ⁶	447	TSF	49	14
Trip Generation (Passenger Cars)	34	10		44	14	36	50	451										
Trip Generation (Truck PCEs)	9	NEC Lena Rd/Norman Rd	Warehousing ⁷	231	TSF	12	3	15	5	14	19	272						
Trip Generation (Passenger Cars)			7										3	10	2	8	10	131
Trip Generation (Truck PCEs)	10	NWC Lena Rd/Central Ave	Warehousing ⁴										155	TSF	18	5	23	6
Trip Generation (Passenger Cars)			8	3	11	8	6	14	253									
Trip Generation (Truck PCEs)			Total Trip Generation				243	168	411	196	246	442						

Notes: TSF = Thousand Square Feet, FP = Fueling Positions

¹ Trip generation based on rates for Land Use 945 - "Gasoline/Service Station With Convenience Market" from Institute of Transportation Engineers' (ITE) *Trip Generation* (10th Edition).

² Trip generation based on rates for Land Use 933 - "Fast-Food Restaurant without Drive-Through Window" from Institute of Transportation Engineers' (ITE) *Trip Generation* (10th Edition).

³ Rates based on Land Use 154 - "High-Cube Transload and Short-Term Storage Warehouse" from Institute of Transportation Engineers (ITE) *Trip Generation* (10th Ed.+Supplement).

⁴ Rates based on Land Use 150 "Warehousing" from Institute of Transportation Engineers (ITE) *Trip Generation* (10th Ed.+Supplement).

⁵ Trip Generation from "Valley View Warehouse TIA" from Translutions (May, 2018.)

⁶ Trip Generation from "Foisy East Warehouse Traffic Impact Study" from Kimley Horn (June, 2020.)

⁷ Trip Generation from "Gateway South 7 Warehouse TIA" from Translutions (September, 2021.)

- Road. There are no existing bike lanes on Norman Road. Norman Road is classified as Local in the City's General Plan.
- **Foisy Street** is oriented in the north-south direction and is a two-lane roadway. On-street parking is not permitted. There is no posted speed limit on Foisy Street. There are no existing bike lanes on Foisy Street, and it is classified as a Local roadway in the City's General Plan.

6.2 Existing Transit Service

Public transportation services within the City of San Bernardino and near the proposed project include bus transit service (Omnitrans) and commuter rail transportation (Metrolink). These services are further described below.

Bus Service. Public transportation in the City of San Bernardino is provided by Omnitrans, which is the regional transit operator in San Bernardino County. The following transit routes operate near the project:

- **Route 8** provides service near the project site. Route 8 connects the project area to Redlands, Loma Linda, and the San Bernardino Transfer Center. Near the study area, Route 8 travels along Tippecanoe Avenue and Mill Street. Route 8 operates at 60-minute headways during the week. The nearest stop is located near the intersection of Tippecanoe Avenue and Central Avenue.
- **Route 305** serves the City of San Bernardino and Grand Terrace, connecting with the San Bernardino Transit Center, the Montecito Memorial Park, and the Grand Terrace Civic Center. Headways are 60-minutes on weekdays and weekends. The nearest stop is near the intersection of Waterman Avenue and Orange Show Road.

Commuter Rail Service. Commuter rail service is provided by Metrolink, which is operated by the Southern California Regional Rail Authority (SCRRA). Metrolink train service is available between the counties of Ventura, Los Angeles, San Bernardino, Orange, Riverside, and north San Diego. The area is served by the San Bernardino Line, which runs east-west between the San Bernardino Station and the Los Angeles Union Station. The San Bernardino Station is the nearest Metrolink station to the project site and is approximately 3.5 miles from the project area. Figure 10 illustrates the transit lines within the project area.

6.3 Existing Bicycle & Pedestrian Facilities

The City's bikeway network includes three types of facilities and are discussed below:

- **Class I Bikeways** A Class I bikeway is a dedicated travel-way for bicyclists. The most common applications for these facilities are along rivers, canals, and utility rights-of-way, within college campuses, or within and between parks.
- **Class II Bikeways** Class II bikeways delineate the right-of-way assigned to bicyclists along roadways. Bike lane signs and pavement markings help define these bike lanes.
- **Class III Bikeways** Class III bikeways are shared facilities that serve either to provide continuity to other bicycle facilities or designate preferred routes through high demand corridors. These facilities are normally shared with motor vehicles on the street, or with pedestrians on sidewalks.

Figure 11 illustrates the existing bike lanes within the project area. As shown in Figure 11, there are no existing bike lanes on Lena Road or Norman Road within the project area. Figure 12 illustrates the City of San Bernardino's Conceptual Trail System. As shown in Figure 12, bike lanes are proposed on Tippecanoe Avenue, Waterman Avenue, and Orange Show Road within the project area. Pedestrian circulation in San Bernardino is primarily provided via sidewalks. Figure 13 illustrates the existing pedestrian facilities near the project. As illustrated in Figure 13, there are sidewalks adjacent to the project on Norman Road. Foisy Street does not have sidewalks adjacent to the project and sidewalks are continuous on Lena Road.

6.4 Existing Intersection Levels of Service

An intersection level of service analysis was conducted for existing conditions to determine current circulation system performance. Figure 14 shows the existing lane geometrics and stop controls at the study intersections. Existing traffic volumes at study intersections are shown in Figure 15. Detailed volume development worksheets are included in



Legend

- Project Boundary
- Bus Stops
- Route 8
- Route 305



FIGURE 10

Gateway South 8 Warehouse
Transit Facilities



Legend
 Project Boundary



FIGURE 11

Gateway South 8 Warehouse
 Existing Bike Lanes

Conceptual Trail System

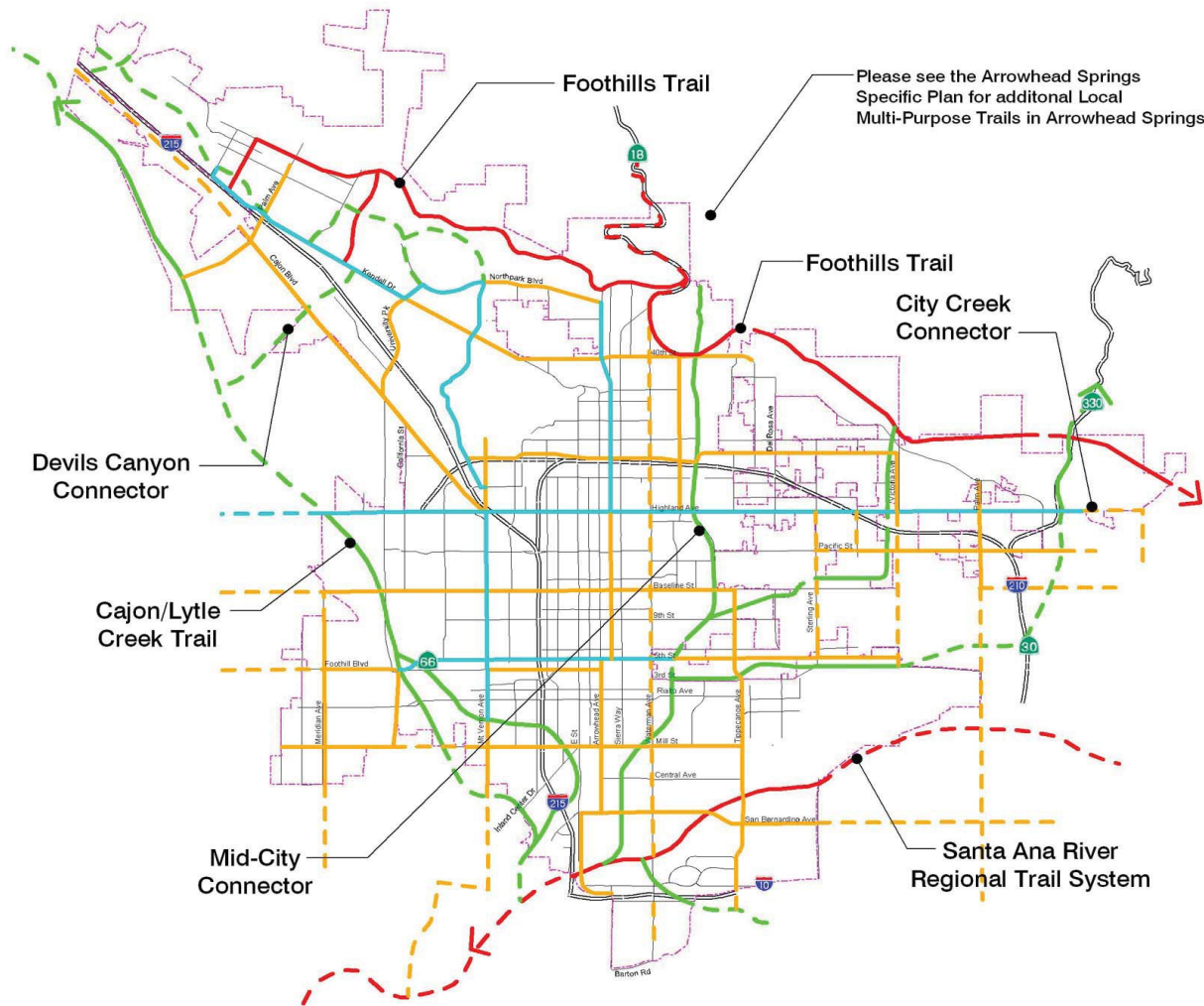

Please see the Arrowhead Springs Specific Plan for additional Local Multi-Purpose Trails in Arrowhead Springs



The City of
SAN BERNARDINO
General Plan

Figure PRT-2

Source: City of San Bernardino General Plan

FIGURE 12

Gateway South 8 Warehouse City of San Bernardino Conceptual Trail System



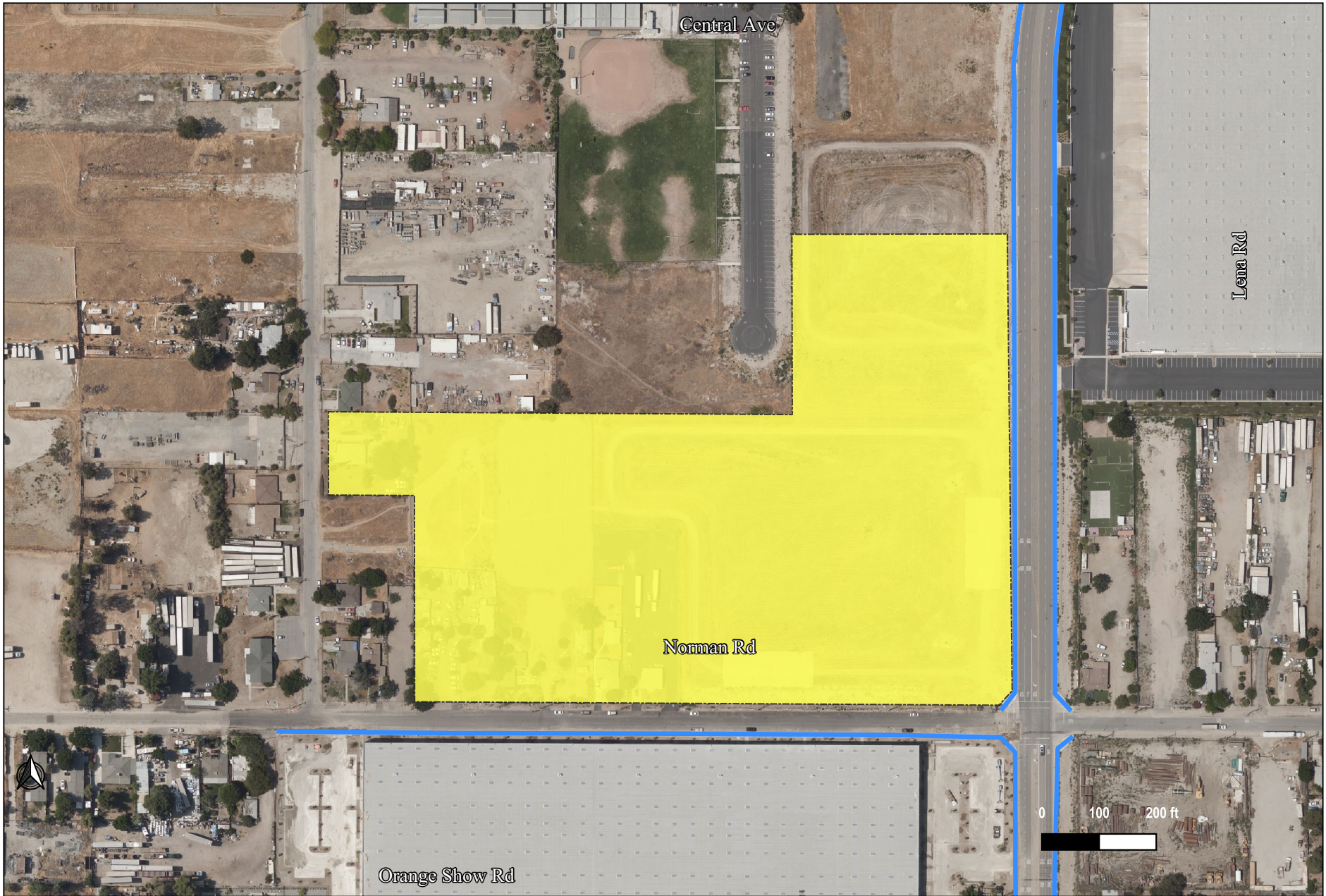

Legend
 Project Boundary Sidewalks



FIGURE 13
Gateway South 8 Warehouse
Pedestrian Sidewalks

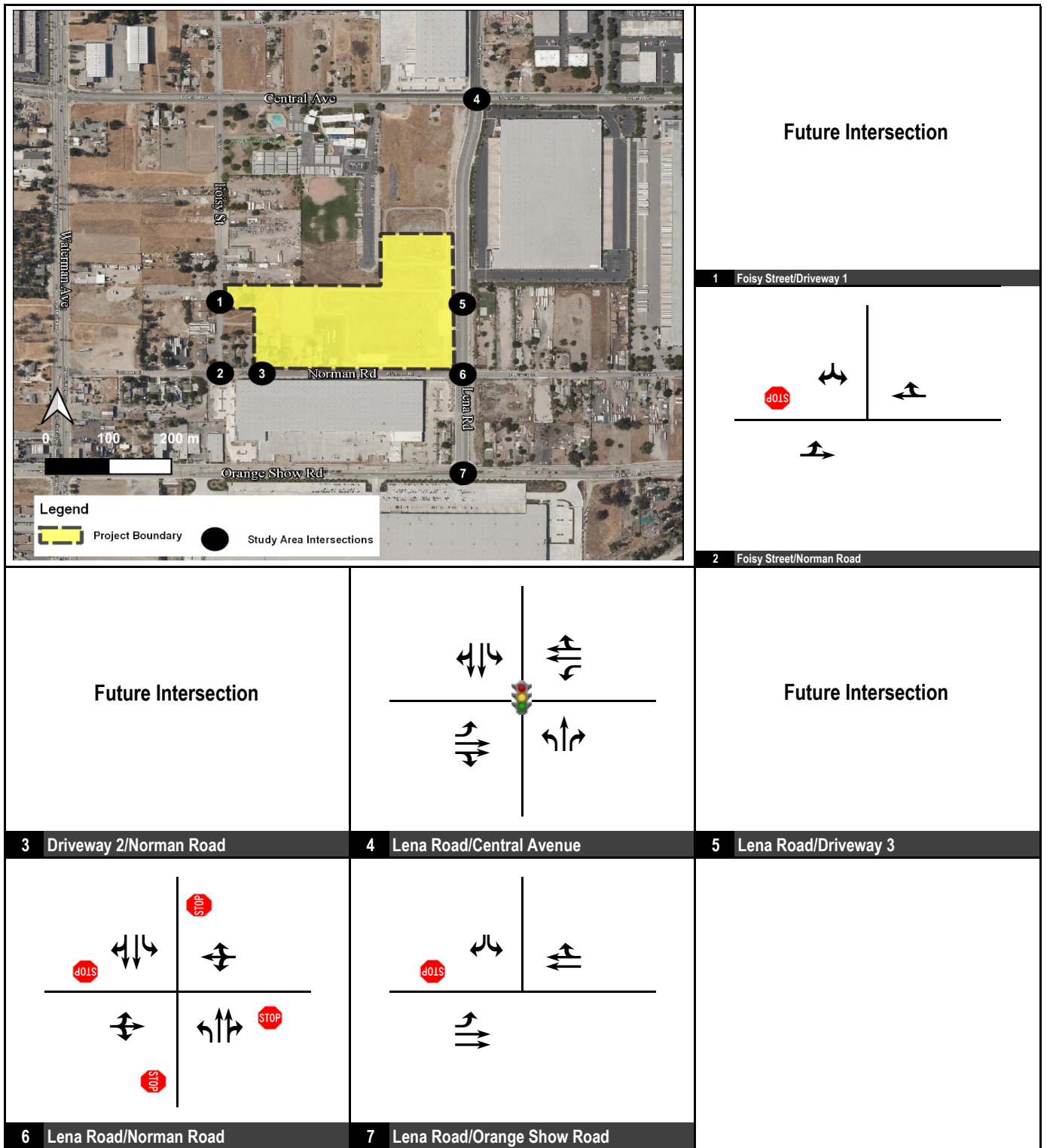

FIGURE 14

Legend

-  Signal
-  Stop Sign

Gateway South 8 Warehouse
Existing Intersection Lane Geometrics and Stop Control



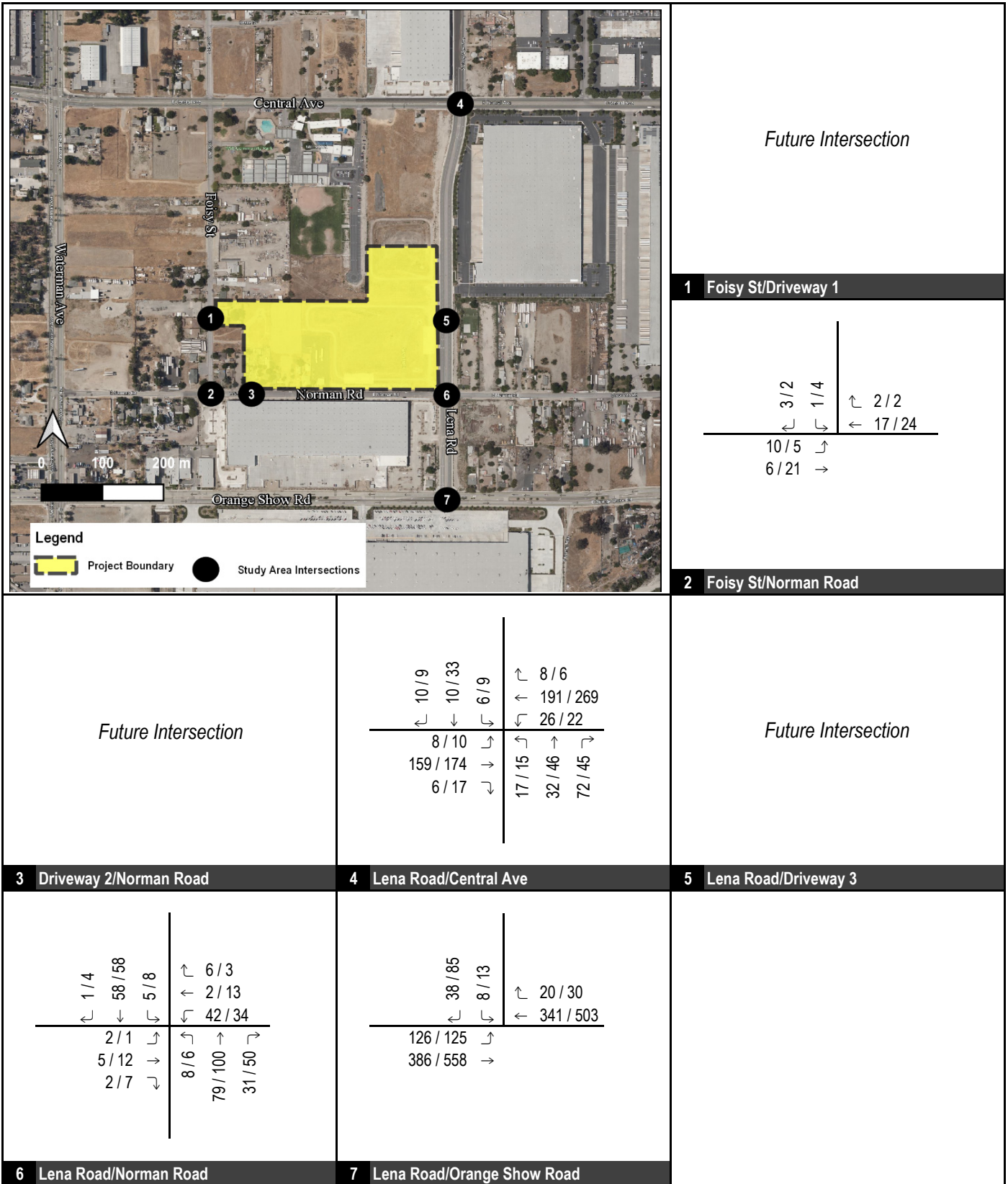

FIGURE 15

XXX / YYY AM / PM Volumes

**Gateway South 8 Warehouse
Existing Peak Hour Traffic Volumes**



Appendix B. The existing levels of service for the study area intersections are summarized in Table J. Level of service calculation worksheets are contained in Appendix C. As shown in Table J, all study area intersections are currently operating at satisfactory levels of service with the exception of the following:

- Lena Road and Orange Show Road (p.m. peak hour).

7.0 OPENING YEAR (2023) CONDITIONS

This section discusses opening year transportation conditions in the study area. It is anticipated that the project will open in 2023.

7.1 Opening Year (2023) Roadway Conditions

Opening year roadway conditions are assumed to be the same as those under existing conditions.

7.2 Opening Year (2023) Transit Service

Transit service under opening year conditions is anticipated to remain the same as under existing conditions.

7.3 Opening Year (2023) Pedestrian & Bicycle Facilities

Pedestrian and bicycle facilities under opening year conditions are anticipated to remain the same as under existing conditions.

7.4 Opening Year (2023) Base Intersection Levels of Service

An intersection level of service analysis was conducted for opening year (2023) base conditions to determine circulation system performance. Opening year (2023) base traffic volumes at study intersections are shown in Figure 16. Detailed volume development worksheets are included in Appendix B. Opening year (2023) base levels of service for the study area intersections are summarized in Table K. Level of service calculation worksheets are contained in Appendix C. As shown in Table K, all study area intersections are forecast to operate at satisfactory levels of service with the exception of the following:

- Lena Road and Orange Show Road (p.m. peak hour).

7.5 Opening Year (2023) Base plus Other Proposed Projects Intersection Levels of Service

An intersection level of service analysis was conducted for opening year (2023) base plus other proposed projects to determine circulation system performance. Opening year (2023) base plus other proposed projects traffic volumes at study intersections are shown in Figure 17. The opening year base plus other proposed projects levels of service for the study area intersections are summarized in Table L. Level of service calculation worksheets are contained in Appendix C. As shown in Table L, all study area intersections are forecast to operate at satisfactory levels of service with the exception of the following:

- Lena Road and Orange Show Road (p.m. peak hour).

7.6 Opening Year (2023) Base plus Other Proposed Projects plus Project Intersection Levels of Service

An intersection level of service analysis was conducted for opening year (2023) base plus other proposed projects plus project to determine circulation system performance. Figure 18 shows the opening year (2023) base plus other proposed projects lane geometrics and stop controls at the study intersections. Opening year (2023) base plus other proposed projects plus project traffic volumes at study intersections are shown in Figure 19. The opening year base plus other proposed projects levels of service for the study area intersections are summarized in Table L. Level of service calculation worksheets are contained in Appendix C. As shown in Table L, all study area intersections are forecast to operate at satisfactory levels of service with the exception of the following:

- Lena Road and Orange Show Road (p.m. peak hour).

Table J: Existing Levels of Service

Intersection	Jurisdiction	LOS Standard	Control	Without Project					
				AM Peak Hour			PM Peak Hour		
				Delay	V/C	LOS	Delay	V/C	LOS
1 . Foisy Street/Driveway 1	San Bernardino	D	TWSC	<i>Future Intersection</i>					
2 . Foisy Street/Norman Road	San Bernardino	D	TWSC	8.5	-	A	8.7	-	A
3 . Driveway 2/Norman Road	San Bernardino	D	TWSC	<i>Future Intersection</i>					
4 . Lena Road/Central Avenue	San Bernardino	D	Signal	25.4	0.13	C	27.7	0.18	C
5 . Lena Road/Driveway 3	San Bernardino	D	TWSC	<i>Future Intersection</i>					
6 . Lena Road/Norman Road	San Bernardino	D	AWSC	8	-	A	8.1	-	A
7 . Lena Road/Orange Show Road	San Bernardino	D	TWSC	20.6	0.038	C	36.3	0.123	E *

Notes:

* Exceeds LOS Standard

LOS = Level of Service

TWSC = Two-Way Stop Control; For TWSC intersections, reported delay is for worst-case movement. Volume to capacity ratios for TWSC intersections operating at LOS C or worse are reported from HCM 6th Edition movement that defines LOS.

For Signalized intersections operating at LOS C or worse, Volume to capacity ratios have been reported using the HCM 2000 methodology, since HCM 6th E reports the maximum V/C ratio.

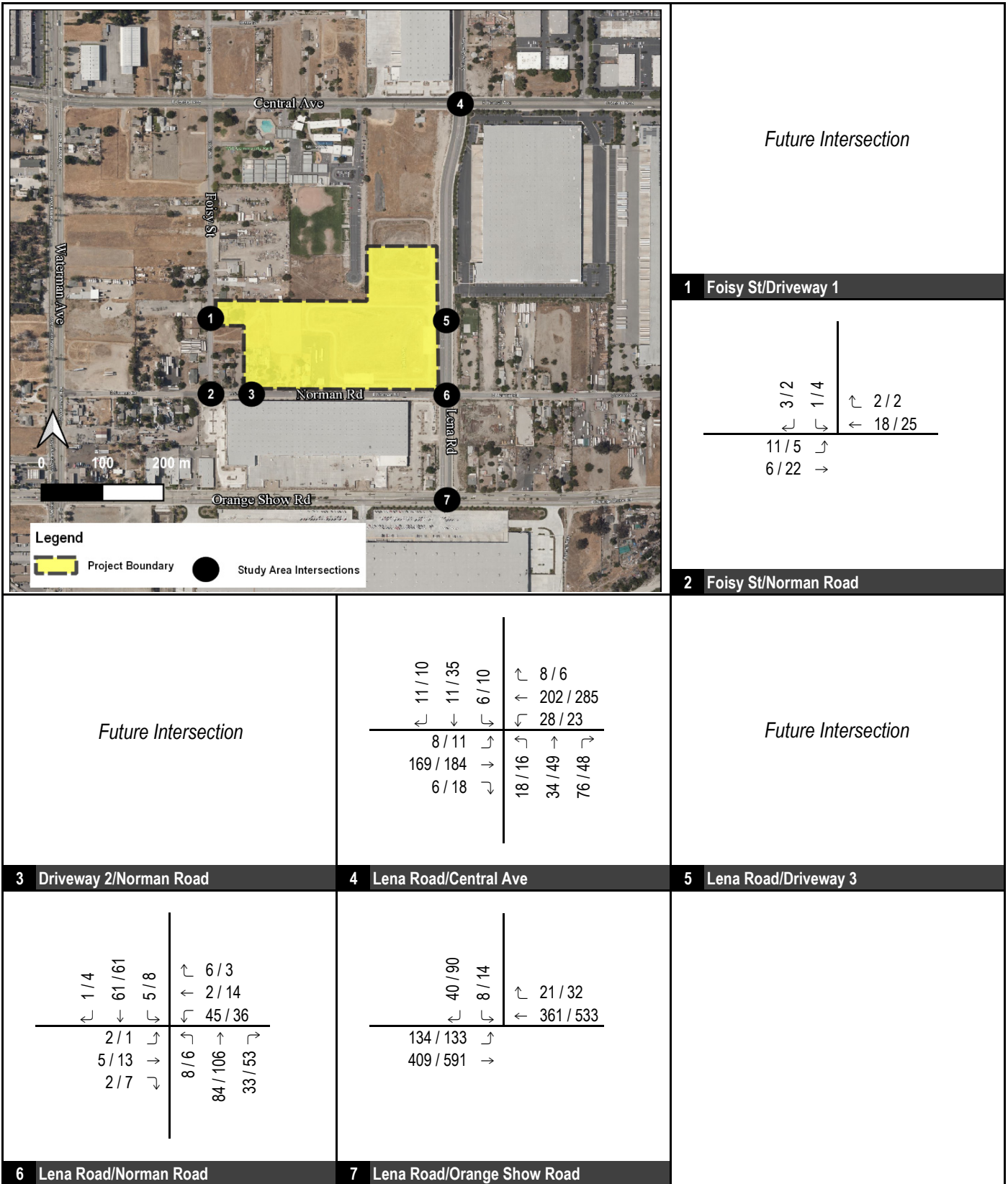

FIGURE 16

XXX / YYY AM / PM Volumes



**Gateway South 8 Warehouse
 Opening Year Base Peak Hour Traffic Volumes**

Table K: Opening Year (2023) Base Levels of Service

Intersection	Jurisdiction	LOS Standard	Control	Without Project					
				AM Peak Hour			PM Peak Hour		
				Delay	V/C	LOS	Delay	V/C	LOS
1 . Foisy Street/Driveway 1	San Bernardino	D	TWSC	<i>Future Intersection</i>					
2 . Foisy Street/Norman Road	San Bernardino	D	TWSC	8.5	-	A	8.7	-	A
3 . Driveway 2/Norman Road	San Bernardino	D	TWSC	<i>Future Intersection</i>					
4 . Lena Road/Central Avenue	San Bernardino	D	Signal	25.4	0.13	C	28.2	0.19	C
5 . Lena Road/Driveway 3	San Bernardino	D	TWSC	<i>Future Intersection</i>					
6 . Lena Road/Norman Road	San Bernardino	D	AWSC	8.1	-	A	8.1	-	A
7 . Lena Road/Orange Show Road	San Bernardino	D	TWSC	22.2	0.042	C	41.8	0.15	E *

Notes:

* Exceeds LOS Standard

LOS = Level of Service

TWSC = Two-Way Stop Control; For TWSC intersections, reported delay is for worst-case movement. Volume to capacity ratios for TWSC intersections operating at LOS C or worse are reported from HCM 6th Edition movement that defines LOS.

For Signalized intersections operating at LOS C or worse, Volume to capacity ratios have been reported using the HCM 2000 methodology, since HCM 6th E reports the maximum V/C ratio.

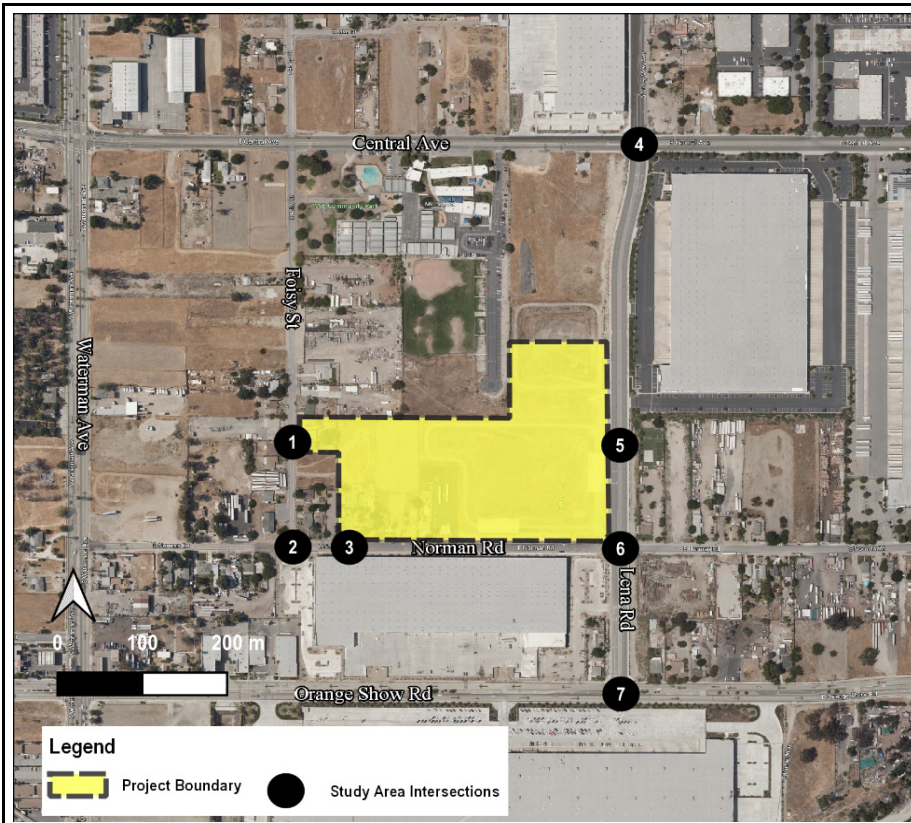

Future Intersection

1 Foisy St/Driveway 1

3 / 2	1 / 4	2 / 2
←	↘	←
11 / 5		26 / 33
14 / 32	→	

2 Foisy St/Norman Road

Future Intersection

13 / 13	17 / 41	17 / 20	16 / 16
←	↓	↘	←
11 / 14		41 / 36	
193 / 214	→	31 / 44	39 / 55
12 / 21	↘	89 / 63	

Future Intersection

3 Driveway 2/Norman Road

4 Lena Road/Central Ave

5 Lena Road/Driveway 3

7 / 10	75 / 85	6 / 8	6 / 4
←	↓	↘	←
8 / 8		47 / 42	2 / 15
6 / 13	→	10 / 7	110 / 122
3 / 10	↘	39 / 55	

63 / 112	11 / 24	29 / 37
←	↘	←
156 / 145		374 / 547
423 / 606	→	

Future Intersection

6 Lena Road/Norman Road

7 Lena Road/Orange Show Road

FIGURE 17

**Gateway South 8 Warehouse
Opening Year Base Plus Other Proposed Projects
Peak Hour Traffic Volumes**

XXX / YYY AM / PM Volumes



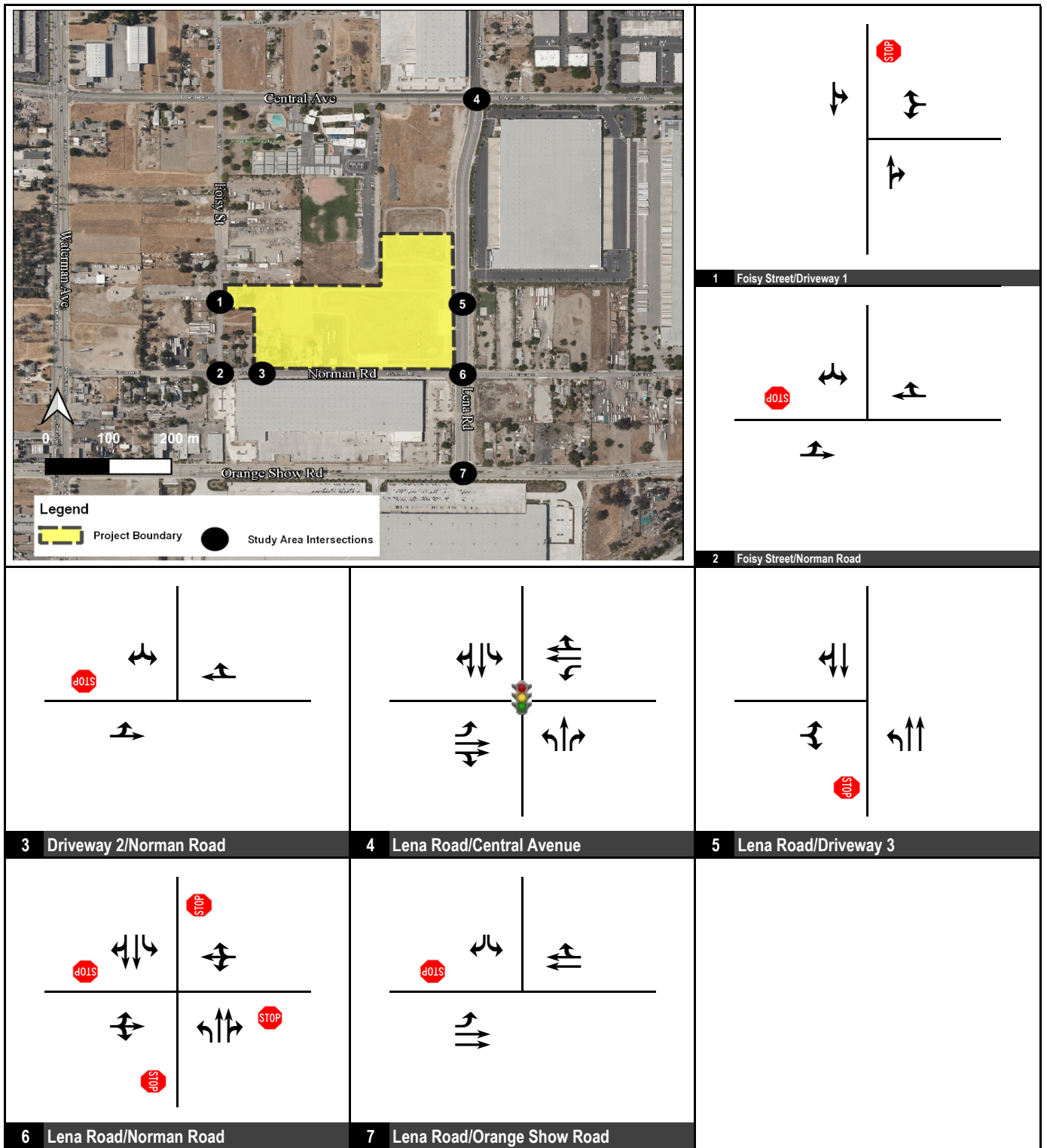

FIGURE 18

Legend

-  Signal
-  Stop Sign

Gateway South 8 Warehouse
Opening Year Base (2023) Base Plus Other Proposed Projects
Intersection Lane Geometrics and Stop Control



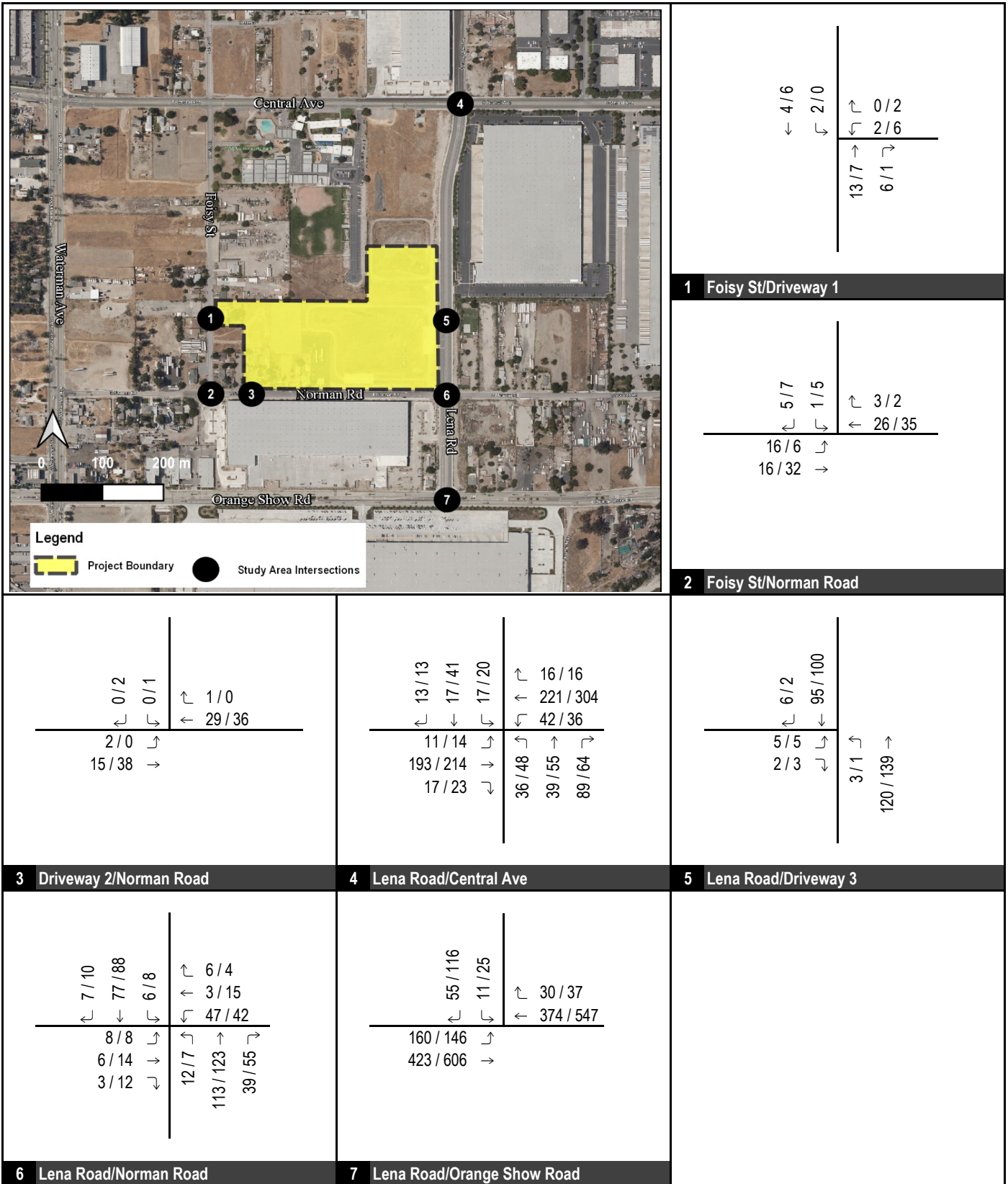

FIGURE 19
Gateway South 8 Warehouse
Opening Year Base Plus Other Proposed Projects Plus Project
Peak Hour Traffic Volumes

XXX / YYY AM / PM Volumes



Table L: Opening Year (2023) Base plus Other Proposed Projects plus Project Levels of Service

Intersection	LOS Standard	Control	Without Project						With Project						V/C Change	
			AM Peak Hour			PM Peak Hour			AM Peak Hour			PM Peak Hour			AM	PM
			Delay	V/C	LOS	Delay	V/C	LOS	Delay	V/C	LOS	Delay	V/C	LOS		
1 . Foisy Street/Driveway 1	D	TWSC	Future Intersection						8.6	-	A	8.5	0.22	A	-	-
2 . Foisy Street/Norman Road	D	TWSC	8.5	-	A	8.8	-	A	8.5	-	A	8.7	-	A	-	-
3 . Driveway 2/Norman Road	D	TWSC	Future Intersection						7.3	-	A	8.6	-	A	-	-
4 . Lena Road/Central Avenue	D	Signal	26.4	0.15	C	28.9	0.22	C	26.3	0.15	C	29.5	0.22	C	0.000	0.000
5 . Lena Road/Driveway 3	D	TWSC	Future Intersection						9.3	-	A	9.3	-	A	-	-
6 . Lena Road/Norman Road	D	AWSC	8.3	-	A	8.4	-	A	8.4	-	A	8.5	-	A	-	-
7 . Lena Road/Orange Show Road	D	TWSC	25.3	0.067	D	54.1	0.288	F *	25.8	0.068	D	55.6	0.288	F *	0.001	0.000

Notes:

* Exceeds LOS Standard

LOS = Level of Service

TWSC = Two-Way Stop Control; For TWSC intersections, reported delay is for worst-case movement. Volume to capacity ratios for TWSC intersections operating at LOS C or worse are reported from HCM 6th Edition movement that defines LOS.

For Signalized intersections operating at LOS C or worse, Volume to capacity ratios have been reported using the HCM 2000 methodology, since HCM 6th Edition reports the maximum V/C ratio.

8.0 CIRCULATION IMPROVEMENTS

The City guidelines require that circulation improvements be recommended at any intersection which operates at unsatisfactory level of service. These include conversion of stop control, signalization, changes to signal phasing, and/or addition of lanes as appropriate.

8.1 Opening Year (2023) Base plus Other Proposed Projects plus Project Conditions

Under opening year (2023) base plus other proposed projects plus project conditions, the following improvements are recommended to restore satisfactory operations:

- **Lena Road and Orange Show Road** – Possible improvements for this intersection could be the installation of all-way stop signs or the installation of a traffic signal. Peak hour signal warrants were conducted at this intersection to determine if a signal was required based on the 2014 California Manual of Uniform Traffic Control Devices Revision 6 (Warrant 3 – Peak Hour). The opening year (2023) base plus other proposed projects peak hour warrants are included in Figure 20 and show that the warrants are not met under the a.m. and p.m. peak hours. To determine if signal warrants would be met in the future, peak hour signal warrants were conducted for year 2040 with project. The year 2040 peak hour volumes were developed from traffic model forecasts from the SBTAM and post-processed consistent with City guidelines. The year 2040 with project volumes are included in Appendix B. The year 2040 with project peak hour warrants are included in Figure 21 and show that the warrants are not met under the a.m. and p.m. peak hours. Therefore, based on the recommendation of the MUTCD, a signal should not be installed at this intersection. In addition, this intersection operates at satisfactory LOS with an all-way stop control and this should be considered if deemed necessary by the City. The project related increase in v/c ratio is 0.001 for intersections operating at LOS D. The project related v/c ratio is 1.1 in the p.m. peak hour, which is less than the City's guidance of 0.01 for intersections operating at LOS F. The intersection operations are not deficient due to the project. Therefore, based on discussion with City staff, a fair share calculation is not required for this intersection.

The resulting levels of service for opening year (2023) base plus other proposed projects plus project improvement conditions are included in Table M. Figure 22 illustrates the recommended improvements. With the implementation of recommended improvements, all intersections will operate at satisfactory levels of service.

9.0 VMT ANALYSIS

Based on the City guidelines, there are three types of screening criteria that lead agencies can apply to screen projects from a project-level VMT assessment. These screening steps include Transit Priority Area Screening, Low VMT Area Screening, Project Type Screening. The SBCTA low VMT area screening tool is included in Appendix D. The project does not screen out from any of the steps mentioned above and therefore, a complete VMT analysis and forecasting through the SBTAM model was conducted to determine if the project may have a significant VMT impact. The VMT analysis included below analyzes the project generated VMT and project effect on VMT consistent with the City guidelines. Based on the City guidelines, this report analyzes the project generated VMT and project effect on VMT for the following scenarios:

1. Baseline conditions.
2. Baseline plus project conditions.
3. Year 2040 without project conditions; and
4. Year 2040 plus project conditions.

CEQA VMT Impact Thresholds

The City guidelines have established thresholds of significance for project generated VMT for use as part of the environmental review process under CEQA. The following would result in a significant project generated VMT:

WARRANT 3, PEAK HOUR

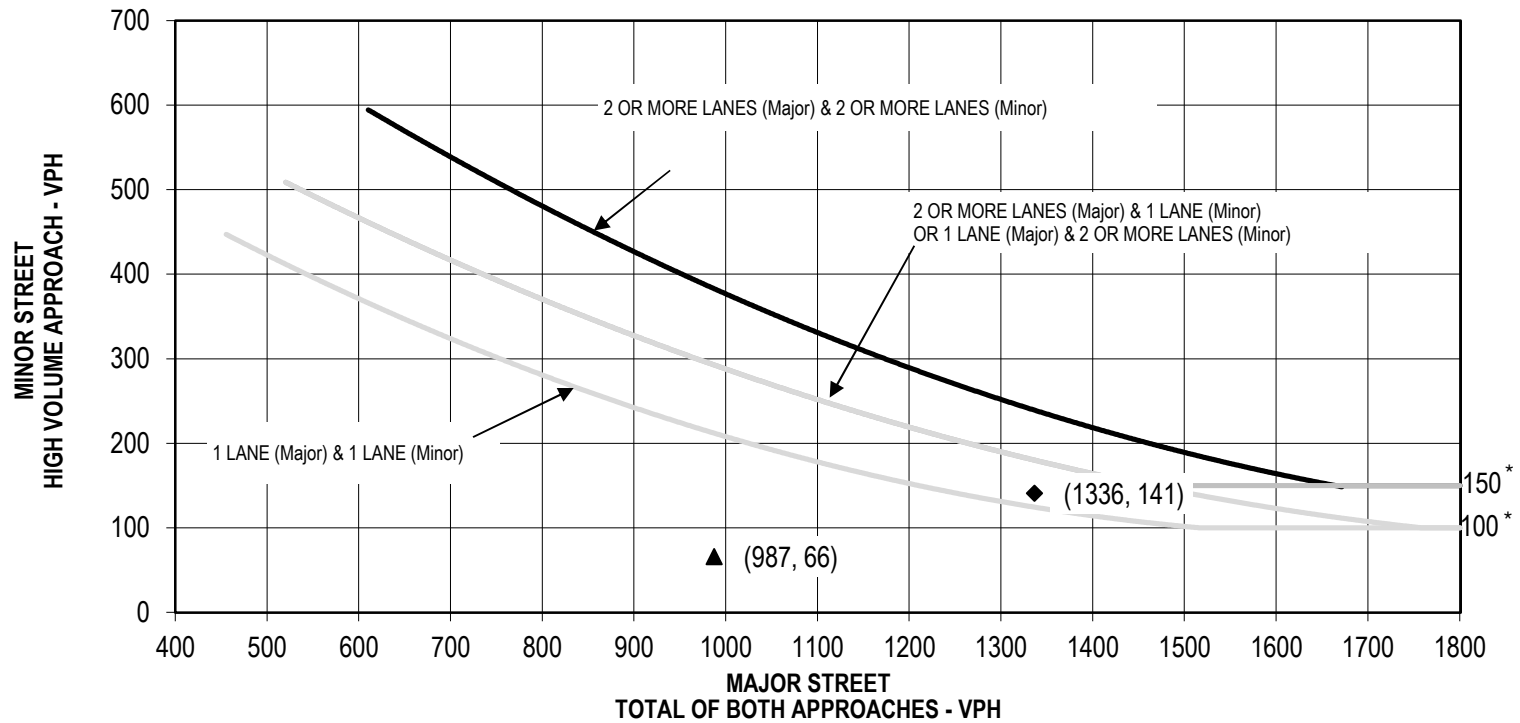

★ 150 VPH applies as the lower threshold volume for a minor street approach with two or more lanes and 100 VPH applies as the lower threshold volume for a minor street approaching with one lane.

FIGURE 20

- ▲ AM Peak Hour
- ◆ PM Peak Hour

SOURCE: MANUAL ON UNIFORM TRAFFIC CONTROL DEVICES REVISION 6 2014 EDITION, FIGURE 4C-3

**Gateway South 8 Warehouse
Signal Warrant for Lena Road/Orange Show Road
Opening Year (2023) Base plus Other Proposed Projects plus Project Peak Hour Signal Warrant**



WARRANT 3, PEAK HOUR

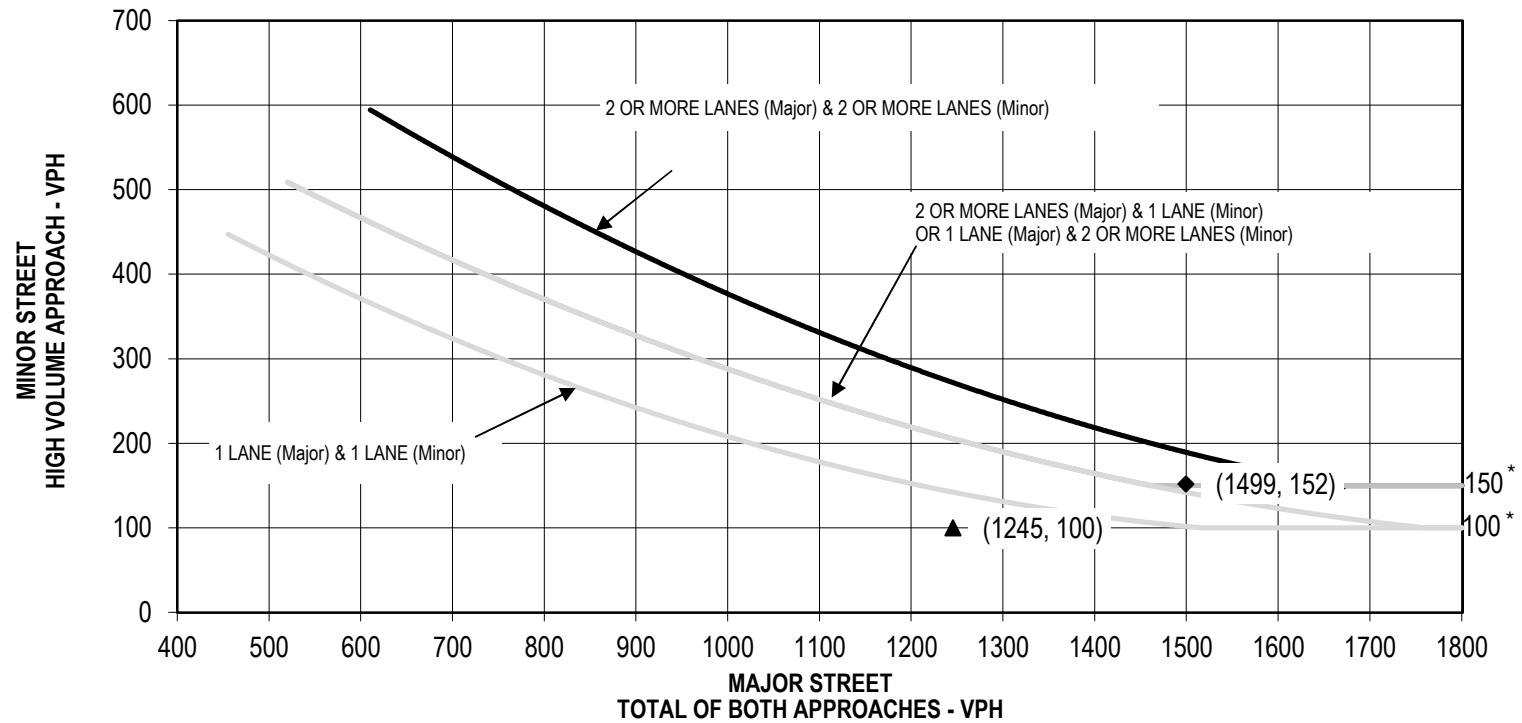

★ 150 VPH applies as the lower threshold volume for a minor street approach with two or more lanes and 100 VPH applies as the lower threshold volume for a minor street approaching with one lane.

FIGURE 21

- ▲ AM Peak Hour
- ◆ PM Peak Hour

SOURCE: MANUAL ON UNIFORM TRAFFIC CONTROL DEVICES REVISION 6 2014 EDITION, FIGURE 4C-3

**Gateway South 8 Warehouse
Signal Warrant for Lena Road/Orange Show Road
Year 2040 With Project Peak Hour Signal Warrants**



Table M: Opening Year (2023) Base plus Other Proposed Projects plus Project With Improvements Levels of Service

Intersection	Jurisdiction	LOS Standard	Control	With Project				With Project With Improvements				
				AM Peak Hour		PM Peak Hour		AM Peak Hour		PM Peak Hour		
				Delay	LOS	Delay	LOS	Control	Delay	LOS	Delay	LOS
5 . Lena Road/Orange Show Road	San Bernardino	D	TWSC	25.8	D	55.6	F *	AWSC	11.7	B	26.4	D

Notes:

* Exceeds LOS Standard

LOS = Level of Service

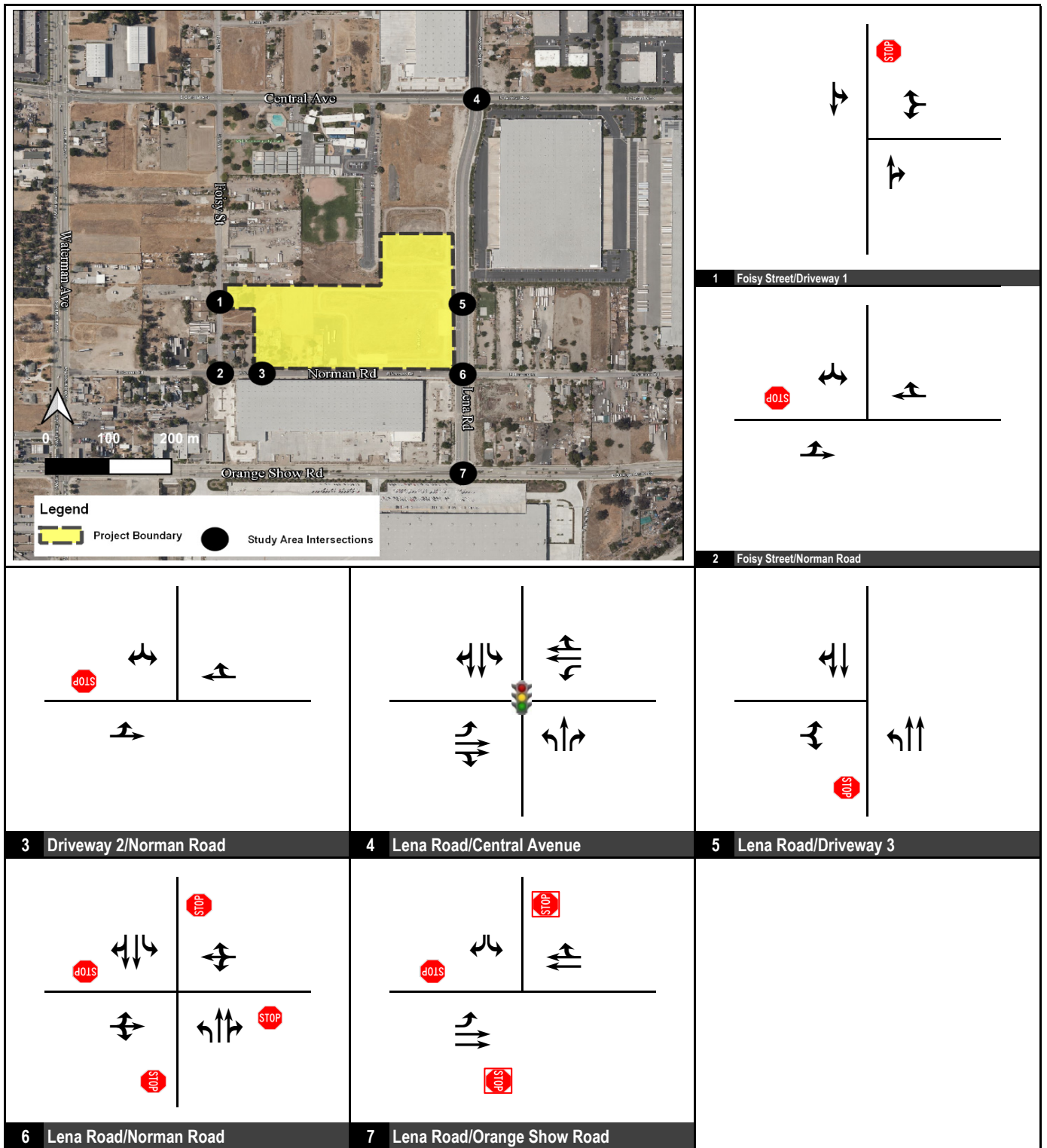

FIGURE 22

Legend

- Signal
- Stop Sign
- Improvements

**Gateway South 8 Warehouse
Opening Year (2023) Base Plus Other Proposed Projects plus Project
With Improvements Intersection Geometrics and Stop Control**



1. The baseline plus project generated VMT per service population exceeds the City of San Bernardino General Plan Buildout VMT per service population, or
2. The cumulative (2040) plus project generated VMT per service population exceeds the City of San Bernardino General Plan Buildout VMT per service population.

The project's effect on VMT would be considered significant if it resulted in the cumulative link-level boundary VMT per service population within the City of San Bernardino to increase under the plus project condition to the no project condition.

Project Generated VMT

The project generated VMT per service population is compared back to the appropriate benchmark noted in the Impact thresholds section above under baseline and year 2040 conditions.

Baseline Conditions

The baseline VMT conditions is derived from the SBCTA Screening tool. The baseline VMT per service population from the screening tool is 29.6 miles.

Baseline Plus Project Conditions

The baseline plus project conditions was derived from a SBTAM model run by adding the project related Socio-Economic Data (SED), which is based on SCAG's employee forecast data to Traffic Analysis Zone (TAZ) 53806201 and moving the baseline no project SED data to an adjacent TAZ. The project was coded using a service population of 152. The project generated VMT was extracted from the model using the origin-destination trip matrix. Table N shows the baseline plus project VMT per service population. As shown in Table N, the baseline plus project VMT per service population is 24.4 miles. Based on the City thresholds, a project would have a significant VMT impact if the baseline plus project generated VMT per service population exceeds the City's General Plan Buildout VMT per service population of 31.6 miles. The baseline plus project VMT per service population is 24.4 miles, which is less than the City's General Plan Buildout VMT per service population of 31.6 miles, therefore, the project does not have an VMT impact under baseline plus project conditions.

Table N: Project Generated VMT

Baseline	Project
Population	-
Employment	152
Service Population	152
Homebased Work (HBW) VMT*	2,556
OD VMT*	3,173
HBW VMT per employee	16.8
OD VMT per service population	24.4
City Threshold**	31.6
Impact Less Than Significant?	Yes
2040	Project
Population	-

Employment	152
Service Population	152
Homebased Work (HBW) VMT*	2,441
OD VMT*	3,856
HBW VMT per employee	16.1
OD VMT per service population	25.4
City Threshold**	31.6
Impact Less Than Significant?	Yes

*: Derived from a SBTAM model run by adding project related SED, based on SCAG's employee forecast data. .

** : Obtained from SBCTA SB743 screening tool (<https://www.gosbcta.com/vmtscreening>)

Year 2040 Conditions

The year 2040 VMT per service population is derived from the SBCTA Screening tool. the year 2040 VMT per service population from the screening tool is 31.6 miles.

Year 2040 Plus Project Conditions

The year 2040 plus project conditions was derived from a SBTAM model run by adding the project related Socio-Economic Data (SED), which is based on SCAG's employee forecast data to Traffic Analysis Zone (TAZ) 53806201 and moving the year 2040 no project SED data to an adjacent TAZ. The project was coded using a service population of 152. The project generated VMT was extracted from the model using the origin-destination trip matrix. Table N shows the year 2040 plus project VMT per service population. As shown in Table N, the year 2040 plus project VMT per service population is 25.4 miles. The year 2040 VMT per service population for the City is 31.6 miles. Based on the City thresholds, a project would have a significant VMT impact if the year 2040 plus project generated VMT per service population exceeds the City's General Plan Buildout VMT per service population. The year 2040 plus project VMT per service population is 25.4 miles, which is less than the City's General Plan Buildout VMT per service population of 31.6 miles, and therefore, the project does not have an VMT impact under year 2040 plus project conditions.

Project Effect on VMT

The project effect on VMT compares how the project changes VMT on the Citywide network and compares it to the no project condition under baseline and year 2040 conditions. The project effect on VMT was estimated using the SBTAM using the City of San Bernardino boundary and extracting the total link-level VMT for both the without and with project conditions consistent with the City guidelines.

Baseline Plus Project Conditions

Table O below shows the baseline plus project effect on VMT per service population. As shown in Table O, the baseline plus project VMT per service population is 11.010 miles. The baseline no project VMT per service population for the City is 11.0166 miles. Based on the City thresholds, a project would have a significant VMT impact if the baseline VMT per service population within the City increases under the plus project condition compared to the no project condition. The baseline plus project VMT per service population does not increase when compared to the no project condition, therefore, the project does not have an VMT impact under baseline plus project conditions.

Year 2040 Plus Project Conditions

Table O below shows the year 2040 plus project VMT per service population. As shown in Table O, the year 2040 plus project VMT per service population is 12.382 miles. The year 2040 no project VMT per service population for the City is 12.384 miles. Based on the City thresholds, a project would have a significant VMT impact if the year 2040 VMT per service population within the City increases under the plus project condition compared to the no project condition. The year 2040 plus project VMT per service population does not increase when compared to the no project condition, therefore, the project does not have an VMT impact under year 2040 plus project conditions.

Table O: Project Effect on VMT

	With Project	Without Project	Difference
Baseline			
Roadway VMT	3,565,903	3,566,315	-
Service Population	323,874	323,722	-
VMT per service population	11.010	11.0166	-0.0064
Year 2040			
Roadway VMT	4,665,050	4,664,057	-
Service Population	376,749	376,597	-
VMT per service population	12.382	12.384	-0.0024

10.0 SUMMARY & CONCLUSIONS

The project proposes the construction of approximately 304,558 square feet of high-cube warehousing uses. Access to the project will be provided via three driveways. The driveways will provide full-access ingress/egress to the project. With the implementation of the recommended improvements, all intersections will operate at satisfactory levels of service.

APPENDIX A: TRAFFIC COUNTS

City of San Bernardino
 N/S: Foisy Street
 E/W: Norman Road
 Weather: Clear

File Name : SBC_Foisy_Norman AM
 Site Code : 99921350
 Start Date : 7/13/2021
 Page No : 1

Groups Printed- Passenger Vehicles - Large 2 Axle Vehicles - 3 Axle Vehicles - 4+ Axle Trucks

Start Time	Foisy Street Southbound			Norman Road Westbound			Norman Road Eastbound			Int. Total
	Left	Right	App. Total	Thru	Right	App. Total	Left	Thru	App. Total	
07:00 AM	0	1	1	3	0	3	1	2	3	7
07:15 AM	0	0	0	2	0	2	0	1	1	3
07:30 AM	0	1	1	2	0	2	1	2	3	6
07:45 AM	0	0	0	3	1	4	0	1	1	5
Total	0	2	2	10	1	11	2	6	8	21
08:00 AM	0	1	1	5	0	5	3	1	4	10
08:15 AM	0	0	0	3	0	3	1	0	1	4
08:30 AM	1	2	3	2	2	4	2	2	4	11
08:45 AM	0	0	0	4	0	4	2	3	5	9
Total	1	3	4	14	2	16	8	6	14	34
Grand Total	1	5	6	24	3	27	10	12	22	55
Apprch %	16.7	83.3		88.9	11.1		45.5	54.5		
Total %	1.8	9.1	10.9	43.6	5.5	49.1	18.2	21.8	40	
Passenger Vehicles	1	4	5	22	3	25	9	12	21	51
% Passenger Vehicles	100	80	83.3	91.7	100	92.6	90	100	95.5	92.7
Large 2 Axle Vehicles	0	1	1	1	0	1	0	0	0	2
% Large 2 Axle Vehicles	0	20	16.7	4.2	0	3.7	0	0	0	3.6
3 Axle Vehicles	0	0	0	0	0	0	1	0	1	1
% 3 Axle Vehicles	0	0	0	0	0	0	10	0	4.5	1.8
4+ Axle Trucks	0	0	0	1	0	1	0	0	0	1
% 4+ Axle Trucks	0	0	0	4.2	0	3.7	0	0	0	1.8

Start Time	Foisy Street Southbound			Norman Road Westbound			Norman Road Eastbound			Int. Total
	Left	Right	App. Total	Thru	Right	App. Total	Left	Thru	App. Total	
Peak Hour Analysis From 07:00 AM to 08:45 AM - Peak 1 of 1										
Peak Hour for Entire Intersection Begins at 08:00 AM										
08:00 AM	0	1	1	5	0	5	3	1	4	10
08:15 AM	0	0	0	3	0	3	1	0	1	4
08:30 AM	1	2	3	2	2	4	2	2	4	11
08:45 AM	0	0	0	4	0	4	2	3	5	9
Total Volume	1	3	4	14	2	16	8	6	14	34
% App. Total	25	75		87.5	12.5		57.1	42.9		
PHF	.250	.375	.333	.700	.250	.800	.667	.500	.700	.773

City of San Bernardino
 N/S: Foisy Street
 E/W: Norman Road
 Weather: Clear

File Name : SBC_Foisy_Norman AM
 Site Code : 99921350
 Start Date : 7/13/2021
 Page No : 2

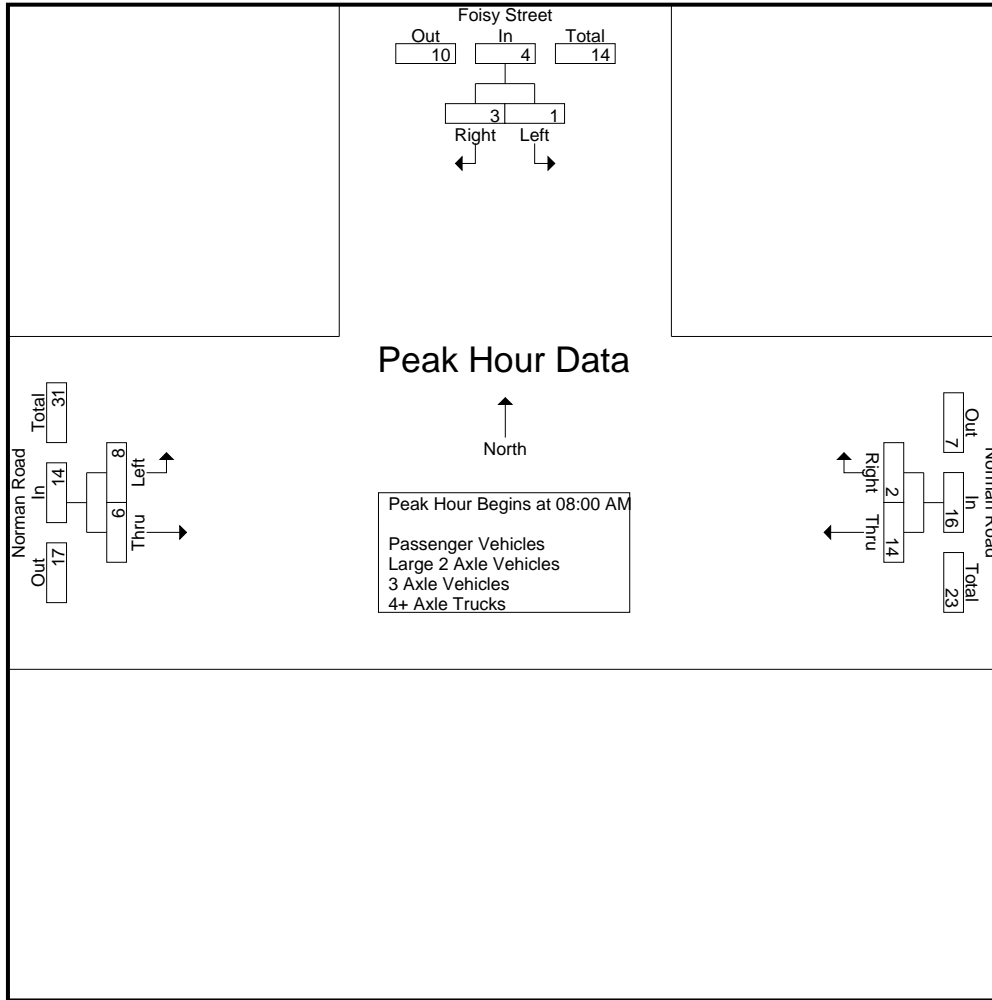

Peak Hour Analysis From 07:00 AM to 08:45 AM - Peak 1 of 1
 Peak Hour for Each Approach Begins at:

	07:45 AM			07:45 AM			08:00 AM		
+0 mins.	0	0	0	3	1	4	3	1	4
+15 mins.	0	1	1	5	0	5	1	0	1
+30 mins.	0	0	0	3	0	3	2	2	4
+45 mins.	1	2	3	2	2	4	2	3	5
Total Volume	1	3	4	13	3	16	8	6	14
% App. Total	25	75		81.2	18.8		57.1	42.9	
PHF	.250	.375	.333	.650	.375	.800	.667	.500	.700

City of San Bernardino
 N/S: Foisy Street
 E/W: Norman Road
 Weather: Clear

File Name : SBC_Foisy_Norman AM
 Site Code : 99921350
 Start Date : 7/13/2021
 Page No : 1

Groups Printed- Passenger Vehicles

Start Time	Foisy Street Southbound			Norman Road Westbound			Norman Road Eastbound			Int. Total
	Left	Right	App. Total	Thru	Right	App. Total	Left	Thru	App. Total	
07:00 AM	0	1	1	3	0	3	1	2	3	7
07:15 AM	0	0	0	2	0	2	0	1	1	3
07:30 AM	0	0	0	2	0	2	1	2	3	5
07:45 AM	0	0	0	3	1	4	0	1	1	5
Total	0	1	1	10	1	11	2	6	8	20
08:00 AM	0	1	1	4	0	4	3	1	4	9
08:15 AM	0	0	0	3	0	3	1	0	1	4
08:30 AM	1	2	3	1	2	3	2	2	4	10
08:45 AM	0	0	0	4	0	4	1	3	4	8
Total	1	3	4	12	2	14	7	6	13	31
Grand Total	1	4	5	22	3	25	9	12	21	51
Apprch %	20	80		88	12		42.9	57.1		
Total %	2	7.8	9.8	43.1	5.9	49	17.6	23.5	41.2	

Start Time	Foisy Street Southbound			Norman Road Westbound			Norman Road Eastbound			Int. Total
	Left	Right	App. Total	Thru	Right	App. Total	Left	Thru	App. Total	
08:00 AM	0	1	1	4	0	4	3	1	4	9
08:15 AM	0	0	0	3	0	3	1	0	1	4
08:30 AM	1	2	3	1	2	3	2	2	4	10
08:45 AM	0	0	0	4	0	4	1	3	4	8
Total Volume	1	3	4	12	2	14	7	6	13	31
% App. Total	25	75		85.7	14.3		53.8	46.2		
PHF	.250	.375	.333	.750	.250	.875	.583	.500	.813	.775

Peak Hour Analysis From 08:00 AM to 08:45 AM - Peak 1 of 1

Peak Hour for Entire Intersection Begins at 08:00 AM

City of San Bernardino
 N/S: Foisy Street
 E/W: Norman Road
 Weather: Clear

File Name : SBC_Foisy_Norman AM
 Site Code : 99921350
 Start Date : 7/13/2021
 Page No : 2

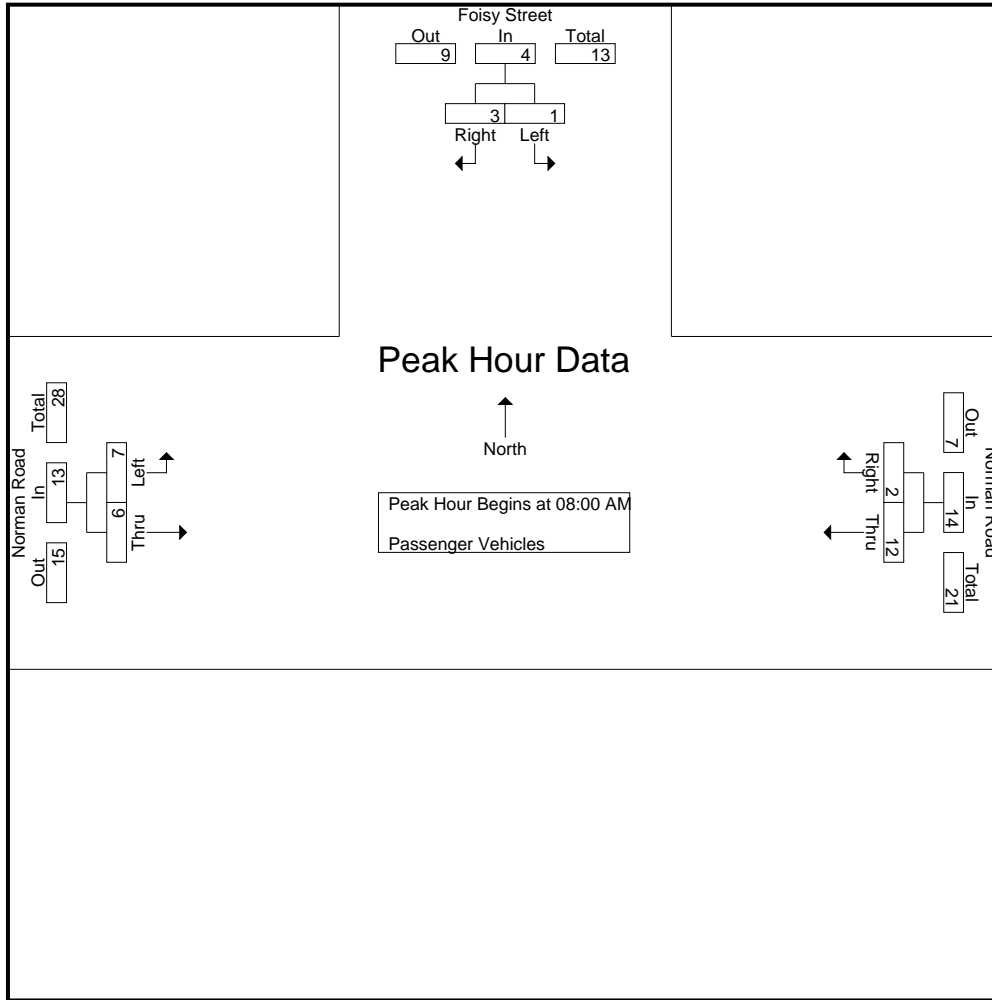

Peak Hour Analysis From 08:00 AM to 08:45 AM - Peak 1 of 1
 Peak Hour for Each Approach Begins at:

	08:00 AM			08:00 AM			08:00 AM		
+0 mins.	0	1	1	4	0	4	3	1	4
+15 mins.	0	0	0	3	0	3	1	0	1
+30 mins.	1	2	3	1	2	3	2	2	4
+45 mins.	0	0	0	4	0	4	1	3	4
Total Volume	1	3	4	12	2	14	7	6	13
% App. Total	25	75		85.7	14.3		53.8	46.2	
PHF	.250	.375	.333	.750	.250	.875	.583	.500	.813

City of San Bernardino
 N/S: Foisy Street
 E/W: Norman Road
 Weather: Clear

File Name : SBC_Foisy_Norman AM
 Site Code : 99921350
 Start Date : 7/13/2021
 Page No : 1

Groups Printed- Large 2 Axle Vehicles

Start Time	Foisy Street Southbound			Norman Road Westbound			Norman Road Eastbound			Int. Total
	Left	Right	App. Total	Thru	Right	App. Total	Left	Thru	App. Total	
07:00 AM	0	0	0	0	0	0	0	0	0	0
07:15 AM	0	0	0	0	0	0	0	0	0	0
07:30 AM	0	1	1	0	0	0	0	0	0	1
07:45 AM	0	0	0	0	0	0	0	0	0	0
Total	0	1	1	0	0	0	0	0	0	1
08:00 AM	0	0	0	1	0	1	0	0	0	1
08:15 AM	0	0	0	0	0	0	0	0	0	0
08:30 AM	0	0	0	0	0	0	0	0	0	0
08:45 AM	0	0	0	0	0	0	0	0	0	0
Total	0	0	0	1	0	1	0	0	0	1
Grand Total	0	1	1	1	0	1	0	0	0	2
Apprch %	0	100		100	0		0	0		
Total %	0	50	50	50	0	50	0	0	0	

Start Time	Foisy Street Southbound			Norman Road Westbound			Norman Road Eastbound			Int. Total
	Left	Right	App. Total	Thru	Right	App. Total	Left	Thru	App. Total	
08:00 AM	0	0	0	1	0	1	0	0	0	1
08:15 AM	0	0	0	0	0	0	0	0	0	0
08:30 AM	0	0	0	0	0	0	0	0	0	0
08:45 AM	0	0	0	0	0	0	0	0	0	0
Total Volume	0	0	0	1	0	1	0	0	0	1
% App. Total	0	0		100	0		0	0		
PHF	.000	.000	.000	.250	.000	.250	.000	.000	.000	.250

Peak Hour Analysis From 08:00 AM to 08:45 AM - Peak 1 of 1
 Peak Hour for Entire Intersection Begins at 08:00 AM

City of San Bernardino
 N/S: Foisy Street
 E/W: Norman Road
 Weather: Clear

File Name : SBC_Foisy_Norman AM
 Site Code : 99921350
 Start Date : 7/13/2021
 Page No : 2

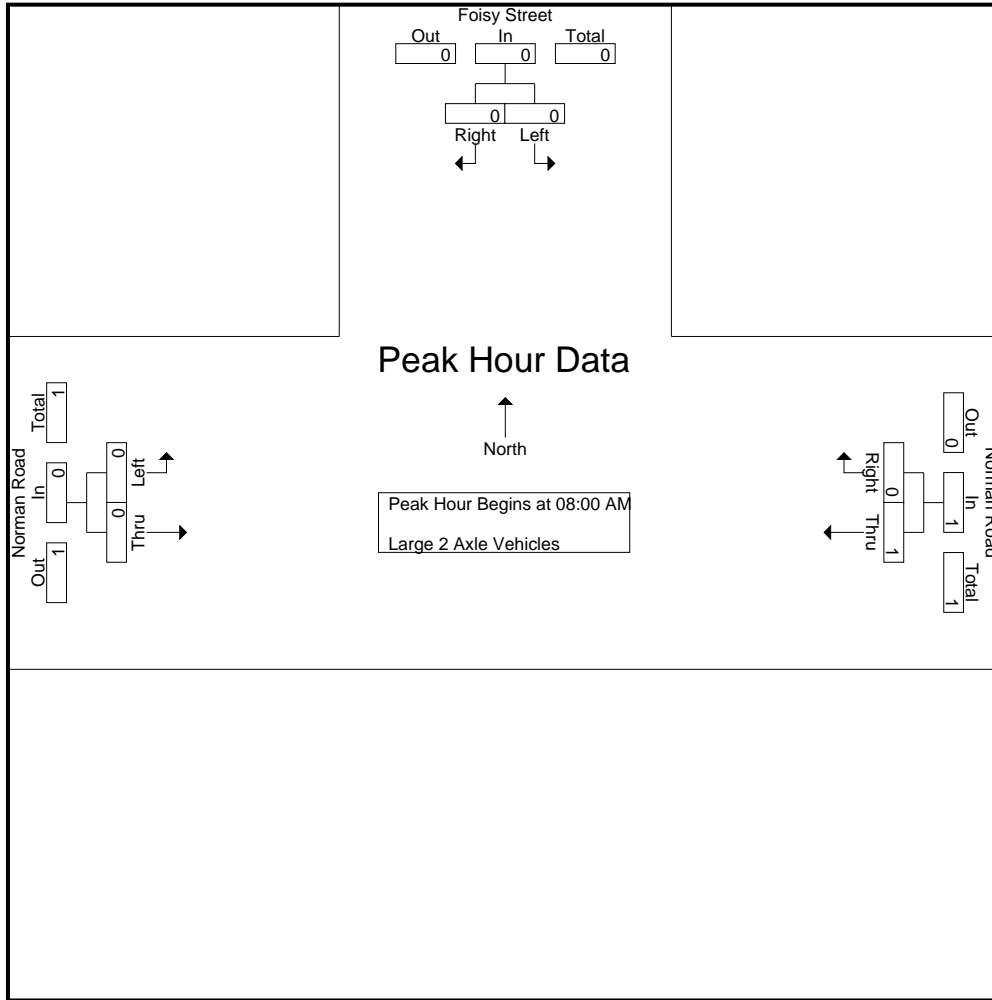

Peak Hour Analysis From 08:00 AM to 08:45 AM - Peak 1 of 1
 Peak Hour for Each Approach Begins at:

	08:00 AM			08:00 AM			08:00 AM		
+0 mins.	0	0	0	1	0	1	0	0	0
+15 mins.	0	0	0	0	0	0	0	0	0
+30 mins.	0	0	0	0	0	0	0	0	0
+45 mins.	0	0	0	0	0	0	0	0	0
Total Volume	0	0	0	1	0	1	0	0	0
% App. Total	0	0	0	100	0	100	0	0	0
PHF	.000	.000	.000	.250	.000	.250	.000	.000	.000

City of San Bernardino
 N/S: Foisy Street
 E/W: Norman Road
 Weather: Clear

File Name : SBC_Foisy_Norman AM
 Site Code : 99921350
 Start Date : 7/13/2021
 Page No : 1

Groups Printed- 3 Axle Vehicles

Start Time	Foisy Street Southbound			Norman Road Westbound			Norman Road Eastbound			Int. Total
	Left	Right	App. Total	Thru	Right	App. Total	Left	Thru	App. Total	
07:00 AM	0	0	0	0	0	0	0	0	0	0
07:15 AM	0	0	0	0	0	0	0	0	0	0
07:30 AM	0	0	0	0	0	0	0	0	0	0
07:45 AM	0	0	0	0	0	0	0	0	0	0
Total	0	0	0	0	0	0	0	0	0	0
08:00 AM	0	0	0	0	0	0	0	0	0	0
08:15 AM	0	0	0	0	0	0	0	0	0	0
08:30 AM	0	0	0	0	0	0	0	0	0	0
08:45 AM	0	0	0	0	0	0	1	0	1	1
Total	0	0	0	0	0	0	1	0	1	1
Grand Total	0	0	0	0	0	0	1	0	1	1
Apprch %	0	0		0	0		100	0		
Total %	0	0		0	0		100	0	100	

Start Time	Foisy Street Southbound			Norman Road Westbound			Norman Road Eastbound			Int. Total
	Left	Right	App. Total	Thru	Right	App. Total	Left	Thru	App. Total	
08:00 AM	0	0	0	0	0	0	0	0	0	0
08:15 AM	0	0	0	0	0	0	0	0	0	0
08:30 AM	0	0	0	0	0	0	0	0	0	0
08:45 AM	0	0	0	0	0	0	1	0	1	1
Total Volume	0	0	0	0	0	0	1	0	1	1
% App. Total	0	0		0	0		100	0		
PHF	.000	.000	.000	.000	.000	.000	.250	.000	.250	.250

Peak Hour Analysis From 08:00 AM to 08:45 AM - Peak 1 of 1
 Peak Hour for Entire Intersection Begins at 08:00 AM

City of San Bernardino
 N/S: Foisy Street
 E/W: Norman Road
 Weather: Clear

File Name : SBC_Foisy_Norman AM
 Site Code : 99921350
 Start Date : 7/13/2021
 Page No : 2

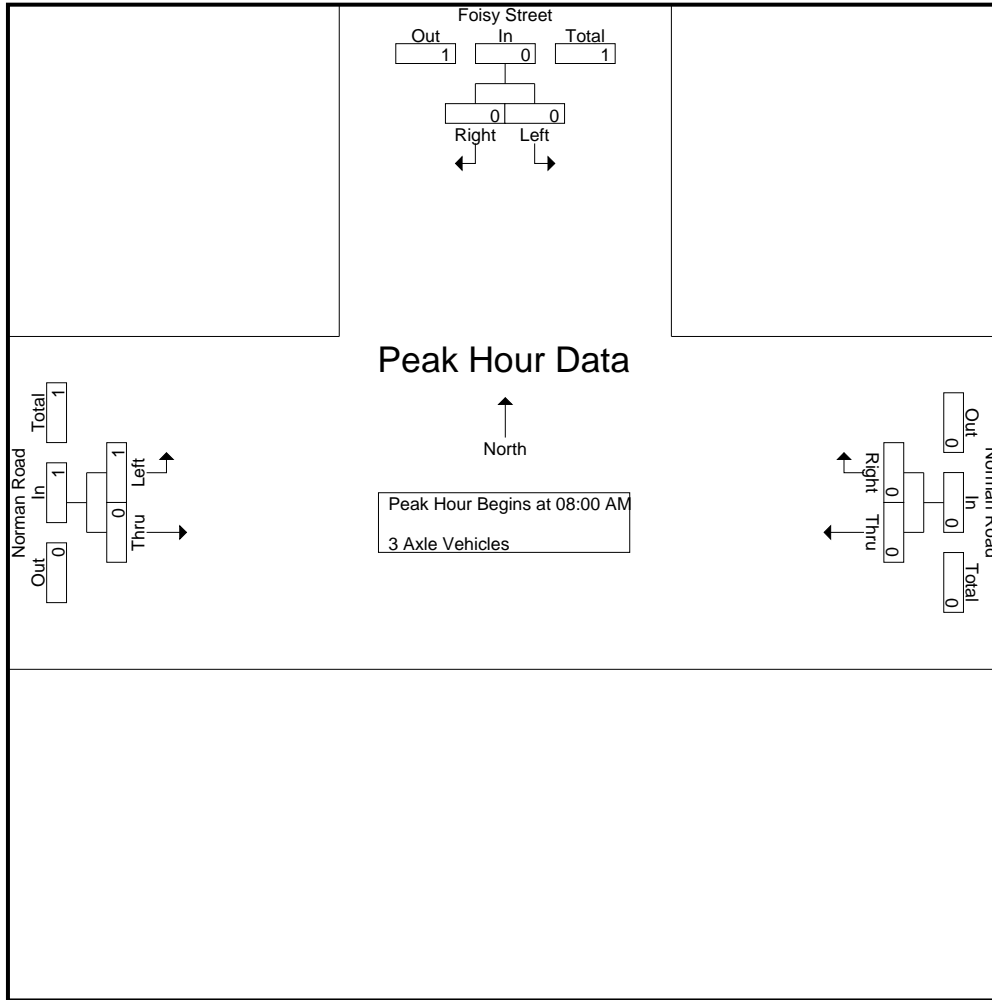

Peak Hour Analysis From 08:00 AM to 08:45 AM - Peak 1 of 1
 Peak Hour for Each Approach Begins at:

	08:00 AM			08:00 AM			08:00 AM		
+0 mins.	0	0	0	0	0	0	0	0	0
+15 mins.	0	0	0	0	0	0	0	0	0
+30 mins.	0	0	0	0	0	0	0	0	0
+45 mins.	0	0	0	0	0	0	1	0	1
Total Volume	0	0	0	0	0	0	1	0	1
% App. Total	0	0	0	0	0	0	100	0	100
PHF	.000	.000	.000	.000	.000	.000	.250	.000	.250

City of San Bernardino
 N/S: Foisy Street
 E/W: Norman Road
 Weather: Clear

File Name : SBC_Foisy_Norman AM
 Site Code : 99921350
 Start Date : 7/13/2021
 Page No : 1

Groups Printed- 4+ Axle Trucks

Start Time	Foisy Street Southbound			Norman Road Westbound			Norman Road Eastbound			Int. Total
	Left	Right	App. Total	Thru	Right	App. Total	Left	Thru	App. Total	
07:00 AM	0	0	0	0	0	0	0	0	0	0
07:15 AM	0	0	0	0	0	0	0	0	0	0
07:30 AM	0	0	0	0	0	0	0	0	0	0
07:45 AM	0	0	0	0	0	0	0	0	0	0
Total	0	0	0	0	0	0	0	0	0	0
08:00 AM	0	0	0	0	0	0	0	0	0	0
08:15 AM	0	0	0	0	0	0	0	0	0	0
08:30 AM	0	0	0	1	0	1	0	0	0	1
08:45 AM	0	0	0	0	0	0	0	0	0	0
Total	0	0	0	1	0	1	0	0	0	1
Grand Total	0	0	0	1	0	1	0	0	0	1
Apprch %	0	0		100	0		0	0		
Total %	0	0		100	0	100	0	0		

Start Time	Foisy Street Southbound			Norman Road Westbound			Norman Road Eastbound			Int. Total
	Left	Right	App. Total	Thru	Right	App. Total	Left	Thru	App. Total	
08:00 AM	0	0	0	0	0	0	0	0	0	0
08:15 AM	0	0	0	0	0	0	0	0	0	0
08:30 AM	0	0	0	1	0	1	0	0	0	1
08:45 AM	0	0	0	0	0	0	0	0	0	0
Total Volume	0	0	0	1	0	1	0	0	0	1
% App. Total	0	0		100	0		0	0		
PHF	.000	.000	.000	.250	.000	.250	.000	.000	.000	.250

Peak Hour Analysis From 08:00 AM to 08:45 AM - Peak 1 of 1

Peak Hour for Entire Intersection Begins at 08:00 AM

City of San Bernardino
 N/S: Foisy Street
 E/W: Norman Road
 Weather: Clear

File Name : SBC_Foisy_Norman AM
 Site Code : 99921350
 Start Date : 7/13/2021
 Page No : 2

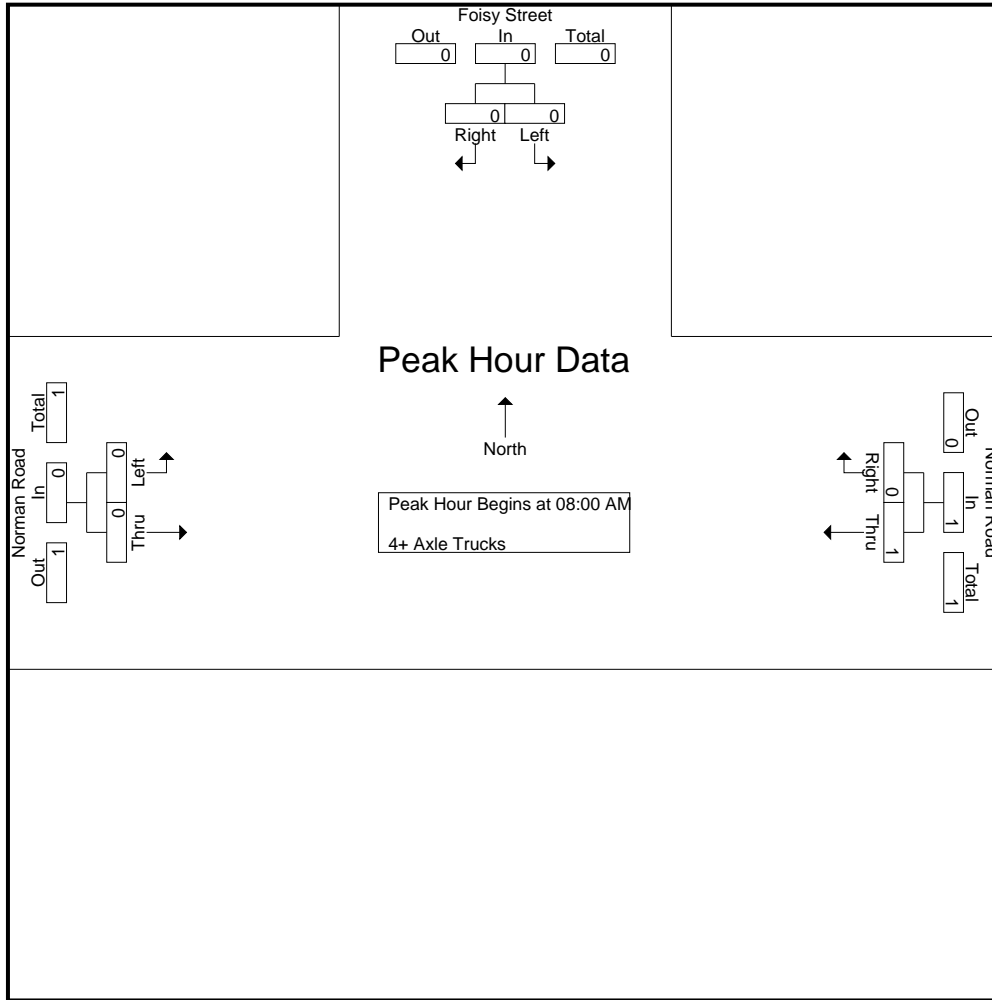

Peak Hour Analysis From 08:00 AM to 08:45 AM - Peak 1 of 1
 Peak Hour for Each Approach Begins at:

	08:00 AM			08:00 AM			08:00 AM		
+0 mins.	0	0	0	0	0	0	0	0	0
+15 mins.	0	0	0	0	0	0	0	0	0
+30 mins.	0	0	0	1	0	1	0	0	0
+45 mins.	0	0	0	0	0	0	0	0	0
Total Volume	0	0	0	1	0	1	0	0	0
% App. Total	0	0	0	100	0	100	0	0	0
PHF	.000	.000	.000	.250	.000	.250	.000	.000	.000

City of San Bernardino
 N/S: Foisy Street
 E/W: Norman Road
 Weather: Clear

File Name : SBC_Foisy_Norman PM
 Site Code : 99921350
 Start Date : 7/13/2021
 Page No : 1

Groups Printed- Passenger Vehicles - Large 2 Axle Vehicles - 3 Axle Vehicles - 4+ Axle Trucks

Start Time	Foisy Street Southbound			Norman Road Westbound			Norman Road Eastbound			Int. Total
	Left	Right	App. Total	Thru	Right	App. Total	Left	Thru	App. Total	
04:00 PM	1	0	1	2	0	2	0	3	3	6
04:15 PM	0	0	0	5	0	5	2	4	6	11
04:30 PM	0	1	1	4	1	5	0	5	5	11
04:45 PM	2	1	3	7	0	7	2	5	7	17
Total	3	2	5	18	1	19	4	17	21	45
05:00 PM	0	0	0	3	0	3	0	2	2	5
05:15 PM	1	1	2	4	0	4	2	4	6	12
05:30 PM	1	0	1	5	2	7	1	7	8	16
05:45 PM	0	1	1	3	0	3	1	0	1	5
Total	2	2	4	15	2	17	4	13	17	38
Grand Total	5	4	9	33	3	36	8	30	38	83
Apprch %	55.6	44.4		91.7	8.3		21.1	78.9		
Total %	6	4.8	10.8	39.8	3.6	43.4	9.6	36.1	45.8	
Passenger Vehicles	4	4	8	27	3	30	8	26	34	72
% Passenger Vehicles	80	100	88.9	81.8	100	83.3	100	86.7	89.5	86.7
Large 2 Axle Vehicles	0	0	0	2	0	2	0	0	0	2
% Large 2 Axle Vehicles	0	0	0	6.1	0	5.6	0	0	0	2.4
3 Axle Vehicles	1	0	1	3	0	3	0	2	2	6
% 3 Axle Vehicles	20	0	11.1	9.1	0	8.3	0	6.7	5.3	7.2
4+ Axle Trucks	0	0	0	1	0	1	0	2	2	3
% 4+ Axle Trucks	0	0	0	3	0	2.8	0	6.7	5.3	3.6

Start Time	Foisy Street Southbound			Norman Road Westbound			Norman Road Eastbound			Int. Total
	Left	Right	App. Total	Thru	Right	App. Total	Left	Thru	App. Total	
Peak Hour Analysis From 04:00 PM to 05:45 PM - Peak 1 of 1										
Peak Hour for Entire Intersection Begins at 04:45 PM										
04:45 PM	2	1	3	7	0	7	2	5	7	17
05:00 PM	0	0	0	3	0	3	0	2	2	5
05:15 PM	1	1	2	4	0	4	2	4	6	12
05:30 PM	1	0	1	5	2	7	1	7	8	16
Total Volume	4	2	6	19	2	21	5	18	23	50
% App. Total	66.7	33.3		90.5	9.5		21.7	78.3		
PHF	.500	.500	.500	.679	.250	.750	.625	.643	.719	.735

City of San Bernardino
 N/S: Foisy Street
 E/W: Norman Road
 Weather: Clear

File Name : SBC_Foisy_Norman PM
 Site Code : 99921350
 Start Date : 7/13/2021
 Page No : 2

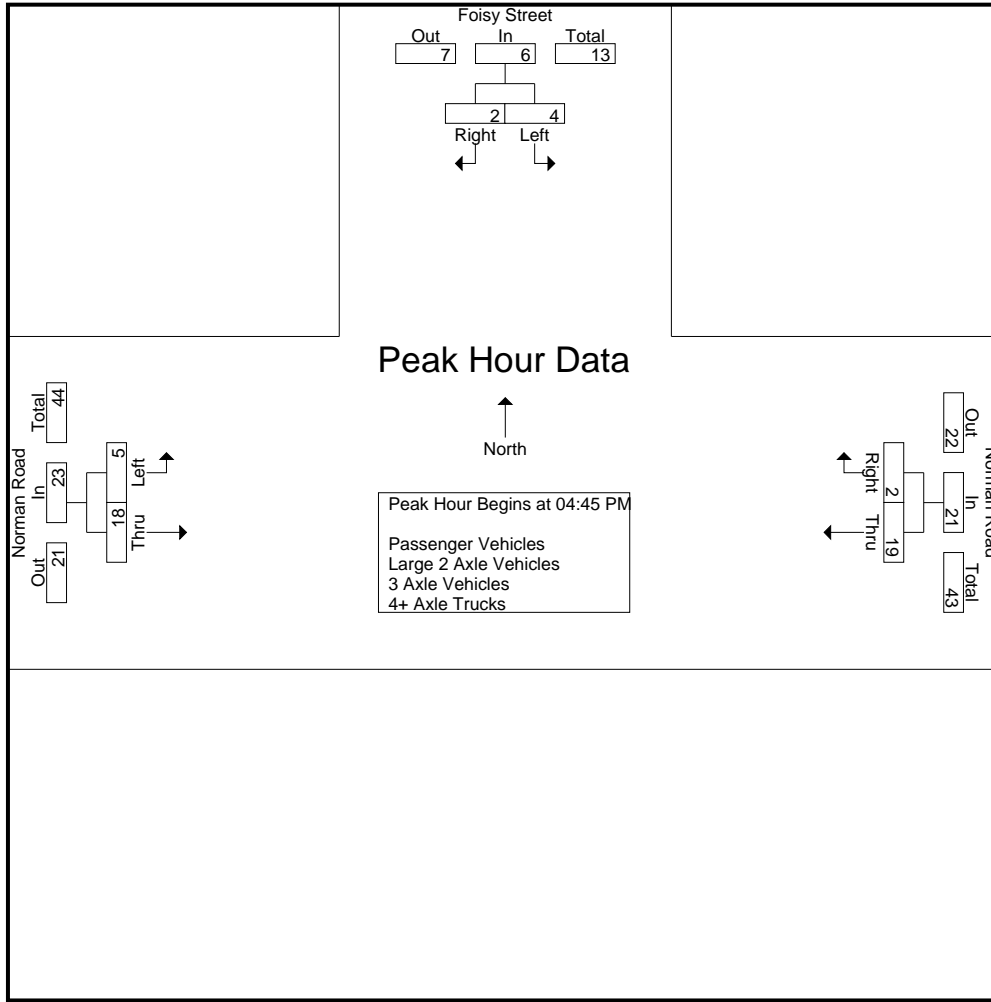

Peak Hour Analysis From 04:00 PM to 05:45 PM - Peak 1 of 1
 Peak Hour for Each Approach Begins at:

	04:30 PM			04:45 PM			04:45 PM		
+0 mins.	0	1	1	7	0	7	2	5	7
+15 mins.	2	1	3	3	0	3	0	2	2
+30 mins.	0	0	0	4	0	4	2	4	6
+45 mins.	1	1	2	5	2	7	1	7	8
Total Volume	3	3	6	19	2	21	5	18	23
% App. Total	50	50		90.5	9.5		21.7	78.3	
PHF	.375	.750	.500	.679	.250	.750	.625	.643	.719

City of San Bernardino
 N/S: Foisy Street
 E/W: Norman Road
 Weather: Clear

File Name : SBC_Foisy_Norman PM
 Site Code : 99921350
 Start Date : 7/13/2021
 Page No : 1

Groups Printed- Passenger Vehicles

Start Time	Foisy Street Southbound			Norman Road Westbound			Norman Road Eastbound			Int. Total
	Left	Right	App. Total	Thru	Right	App. Total	Left	Thru	App. Total	
04:00 PM	0	0	0	1	0	1	0	3	3	4
04:15 PM	0	0	0	4	0	4	2	3	5	9
04:30 PM	0	1	1	4	1	5	0	4	4	10
04:45 PM	2	1	3	5	0	5	2	4	6	14
Total	2	2	4	14	1	15	4	14	18	37
05:00 PM	0	0	0	3	0	3	0	2	2	5
05:15 PM	1	1	2	3	0	3	2	3	5	10
05:30 PM	1	0	1	5	2	7	1	7	8	16
05:45 PM	0	1	1	2	0	2	1	0	1	4
Total	2	2	4	13	2	15	4	12	16	35
Grand Total	4	4	8	27	3	30	8	26	34	72
Apprch %	50	50		90	10		23.5	76.5		
Total %	5.6	5.6	11.1	37.5	4.2	41.7	11.1	36.1	47.2	

Start Time	Foisy Street Southbound			Norman Road Westbound			Norman Road Eastbound			Int. Total
	Left	Right	App. Total	Thru	Right	App. Total	Left	Thru	App. Total	
04:45 PM	2	1	3	5	0	5	2	4	6	14
05:00 PM	0	0	0	3	0	3	0	2	2	5
05:15 PM	1	1	2	3	0	3	2	3	5	10
05:30 PM	1	0	1	5	2	7	1	7	8	16
Total Volume	4	2	6	16	2	18	5	16	21	45
% App. Total	66.7	33.3		88.9	11.1		23.8	76.2		
PHF	.500	.500	.500	.800	.250	.643	.625	.571	.656	.703

Peak Hour Analysis From 04:45 PM to 05:30 PM - Peak 1 of 1

Peak Hour for Entire Intersection Begins at 04:45 PM

City of San Bernardino
 N/S: Foisy Street
 E/W: Norman Road
 Weather: Clear

File Name : SBC_Foisy_Norman PM
 Site Code : 99921350
 Start Date : 7/13/2021
 Page No : 2

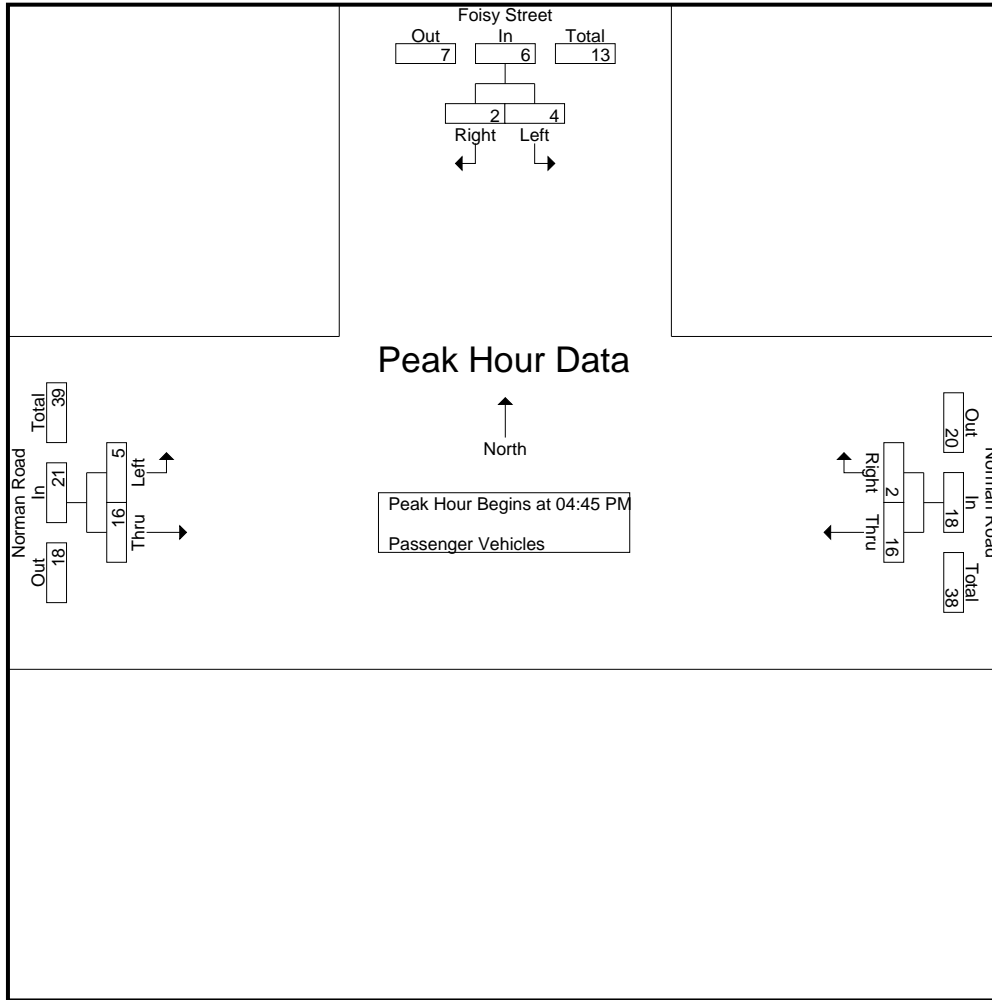

Peak Hour Analysis From 04:45 PM to 05:30 PM - Peak 1 of 1
 Peak Hour for Each Approach Begins at:

	04:45 PM			04:45 PM			04:45 PM		
+0 mins.	2	1	3	5	0	5	2	4	6
+15 mins.	0	0	0	3	0	3	0	2	2
+30 mins.	1	1	2	3	0	3	2	3	5
+45 mins.	1	0	1	5	2	7	1	7	8
Total Volume	4	2	6	16	2	18	5	16	21
% App. Total	66.7	33.3		88.9	11.1		23.8	76.2	
PHF	.500	.500	.500	.800	.250	.643	.625	.571	.656

City of San Bernardino
 N/S: Foisy Street
 E/W: Norman Road
 Weather: Clear

File Name : SBC_Foisy_Norman PM
 Site Code : 99921350
 Start Date : 7/13/2021
 Page No : 1

Groups Printed- Large 2 Axle Vehicles

Start Time	Foisy Street Southbound			Norman Road Westbound			Norman Road Eastbound			Int. Total
	Left	Right	App. Total	Thru	Right	App. Total	Left	Thru	App. Total	
04:00 PM	0	0	0	1	0	1	0	0	0	1
04:15 PM	0	0	0	0	0	0	0	0	0	0
04:30 PM	0	0	0	0	0	0	0	0	0	0
04:45 PM	0	0	0	1	0	1	0	0	0	1
Total	0	0	0	2	0	2	0	0	0	2
05:00 PM	0	0	0	0	0	0	0	0	0	0
05:15 PM	0	0	0	0	0	0	0	0	0	0
05:30 PM	0	0	0	0	0	0	0	0	0	0
05:45 PM	0	0	0	0	0	0	0	0	0	0
Total	0	0	0	0	0	0	0	0	0	0
Grand Total	0	0	0	2	0	2	0	0	0	2
Apprch %	0	0		100	0		0	0		
Total %	0	0		100	0	100	0	0		

Start Time	Foisy Street Southbound			Norman Road Westbound			Norman Road Eastbound			Int. Total
	Left	Right	App. Total	Thru	Right	App. Total	Left	Thru	App. Total	
04:45 PM	0	0	0	1	0	1	0	0	0	1
05:00 PM	0	0	0	0	0	0	0	0	0	0
05:15 PM	0	0	0	0	0	0	0	0	0	0
05:30 PM	0	0	0	0	0	0	0	0	0	0
Total Volume	0	0	0	1	0	1	0	0	0	1
% App. Total	0	0		100	0		0	0		
PHF	.000	.000	.000	.250	.000	.250	.000	.000	.000	.250

Peak Hour Analysis From 04:45 PM to 05:30 PM - Peak 1 of 1
 Peak Hour for Entire Intersection Begins at 04:45 PM

City of San Bernardino
 N/S: Foisy Street
 E/W: Norman Road
 Weather: Clear

File Name : SBC_Foisy_Norman PM
 Site Code : 99921350
 Start Date : 7/13/2021
 Page No : 2

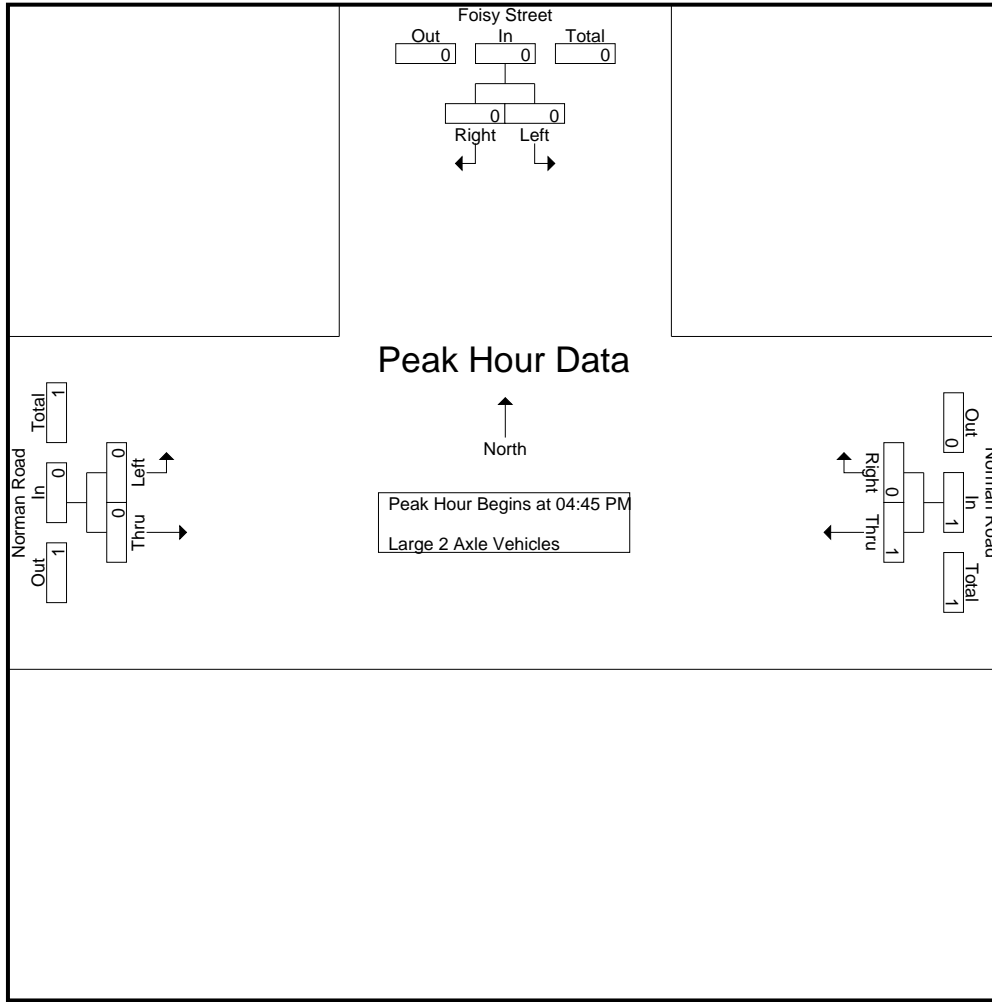

Peak Hour Analysis From 04:45 PM to 05:30 PM - Peak 1 of 1
 Peak Hour for Each Approach Begins at:

	04:45 PM			04:45 PM			04:45 PM		
+0 mins.	0	0	0	1	0	1	0	0	0
+15 mins.	0	0	0	0	0	0	0	0	0
+30 mins.	0	0	0	0	0	0	0	0	0
+45 mins.	0	0	0	0	0	0	0	0	0
Total Volume	0	0	0	1	0	1	0	0	0
% App. Total	0	0	0	100	0	100	0	0	0
PHF	.000	.000	.000	.250	.000	.250	.000	.000	.000

City of San Bernardino
 N/S: Foisy Street
 E/W: Norman Road
 Weather: Clear

File Name : SBC_Foisy_Norman PM
 Site Code : 99921350
 Start Date : 7/13/2021
 Page No : 1

Groups Printed- 3 Axle Vehicles

Start Time	Foisy Street Southbound			Norman Road Westbound			Norman Road Eastbound			Int. Total
	Left	Right	App. Total	Thru	Right	App. Total	Left	Thru	App. Total	
04:00 PM	1	0	1	0	0	0	0	0	0	1
04:15 PM	0	0	0	1	0	1	0	0	0	1
04:30 PM	0	0	0	0	0	0	0	0	0	0
04:45 PM	0	0	0	1	0	1	0	1	1	2
Total	1	0	1	2	0	2	0	1	1	4
05:00 PM	0	0	0	0	0	0	0	0	0	0
05:15 PM	0	0	0	0	0	0	0	1	1	1
05:30 PM	0	0	0	0	0	0	0	0	0	0
05:45 PM	0	0	0	1	0	1	0	0	0	1
Total	0	0	0	1	0	1	0	1	1	2
Grand Total	1	0	1	3	0	3	0	2	2	6
Apprch %	100	0		100	0		0	100		
Total %	16.7	0	16.7	50	0	50	0	33.3	33.3	

Start Time	Foisy Street Southbound			Norman Road Westbound			Norman Road Eastbound			Int. Total
	Left	Right	App. Total	Thru	Right	App. Total	Left	Thru	App. Total	
04:45 PM	0	0	0	1	0	1	0	1	1	2
05:00 PM	0	0	0	0	0	0	0	0	0	0
05:15 PM	0	0	0	0	0	0	0	1	1	1
05:30 PM	0	0	0	0	0	0	0	0	0	0
Total Volume	0	0	0	1	0	1	0	2	2	3
% App. Total	0	0		100	0		0	100		
PHF	.000	.000	.000	.250	.000	.250	.000	.500	.500	.375

Peak Hour Analysis From 04:45 PM to 05:30 PM - Peak 1 of 1

Peak Hour for Entire Intersection Begins at 04:45 PM

City of San Bernardino
 N/S: Foisy Street
 E/W: Norman Road
 Weather: Clear

File Name : SBC_Foisy_Norman PM
 Site Code : 99921350
 Start Date : 7/13/2021
 Page No : 2

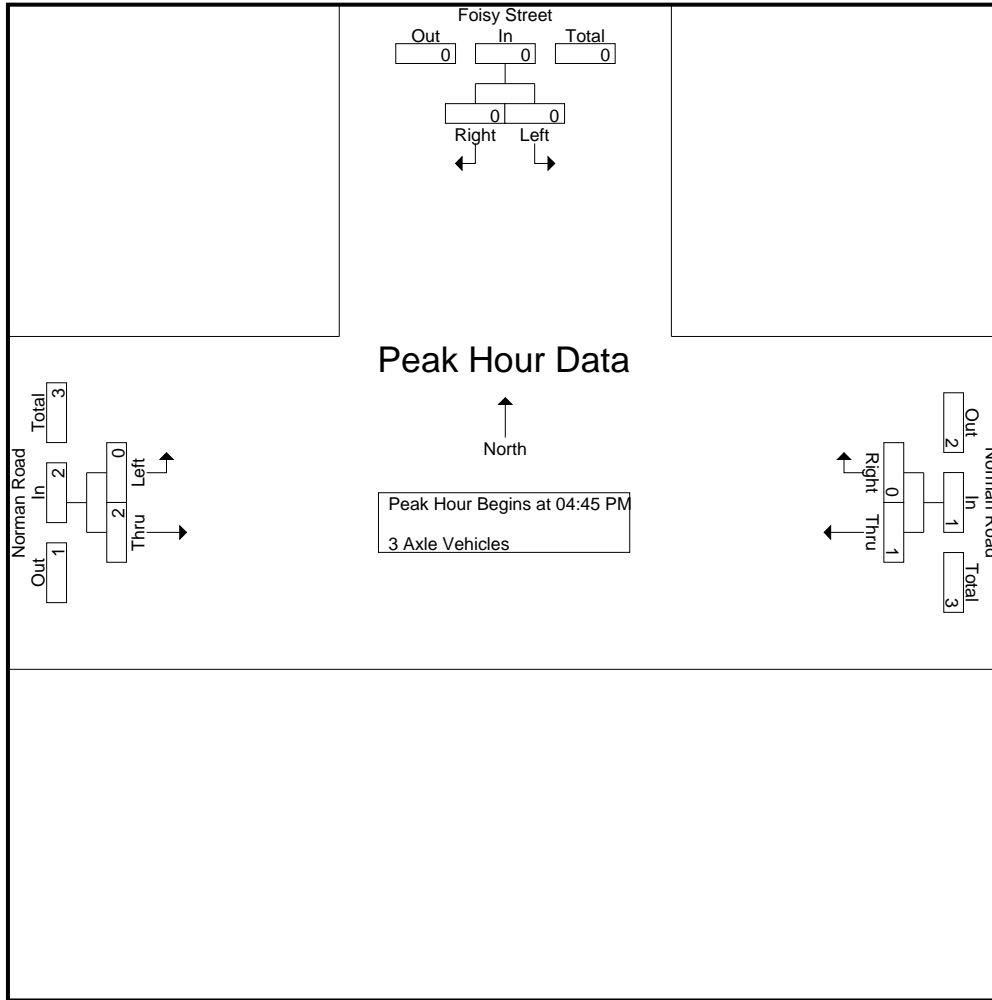

Peak Hour Analysis From 04:45 PM to 05:30 PM - Peak 1 of 1
 Peak Hour for Each Approach Begins at:

	04:45 PM			04:45 PM			04:45 PM		
+0 mins.	0	0	0	1	0	1	0	1	1
+15 mins.	0	0	0	0	0	0	0	0	0
+30 mins.	0	0	0	0	0	0	0	1	1
+45 mins.	0	0	0	0	0	0	0	0	0
Total Volume	0	0	0	1	0	1	0	2	2
% App. Total	0	0	0	100	0	100	0	100	100
PHF	.000	.000	.000	.250	.000	.250	.000	.500	.500

City of San Bernardino
 N/S: Foisy Street
 E/W: Norman Road
 Weather: Clear

File Name : SBC_Foisy_Norman PM
 Site Code : 99921350
 Start Date : 7/13/2021
 Page No : 1

Groups Printed- 4+ Axle Trucks

Start Time	Foisy Street Southbound			Norman Road Westbound			Norman Road Eastbound			Int. Total
	Left	Right	App. Total	Thru	Right	App. Total	Left	Thru	App. Total	
04:00 PM	0	0	0	0	0	0	0	0	0	0
04:15 PM	0	0	0	0	0	0	0	1	1	1
04:30 PM	0	0	0	0	0	0	0	1	1	1
04:45 PM	0	0	0	0	0	0	0	0	0	0
Total	0	0	0	0	0	0	0	2	2	2
05:00 PM	0	0	0	0	0	0	0	0	0	0
05:15 PM	0	0	0	1	0	1	0	0	0	1
05:30 PM	0	0	0	0	0	0	0	0	0	0
05:45 PM	0	0	0	0	0	0	0	0	0	0
Total	0	0	0	1	0	1	0	0	0	1
Grand Total	0	0	0	1	0	1	0	2	2	3
Apprch %	0	0		100	0		0	100		
Total %	0	0		33.3	0	33.3	0	66.7	66.7	

Start Time	Foisy Street Southbound			Norman Road Westbound			Norman Road Eastbound			Int. Total
	Left	Right	App. Total	Thru	Right	App. Total	Left	Thru	App. Total	
04:45 PM	0	0	0	0	0	0	0	0	0	0
05:00 PM	0	0	0	0	0	0	0	0	0	0
05:15 PM	0	0	0	1	0	1	0	0	0	1
05:30 PM	0	0	0	0	0	0	0	0	0	0
Total Volume	0	0	0	1	0	1	0	0	0	1
% App. Total	0	0		100	0		0	0		
PHF	.000	.000	.000	.250	.000	.250	.000	.000	.000	.250

Peak Hour Analysis From 04:45 PM to 05:30 PM - Peak 1 of 1
 Peak Hour for Entire Intersection Begins at 04:45 PM

City of San Bernardino
 N/S: Foisy Street
 E/W: Norman Road
 Weather: Clear

File Name : SBC_Foisy_Norman PM
 Site Code : 99921350
 Start Date : 7/13/2021
 Page No : 2

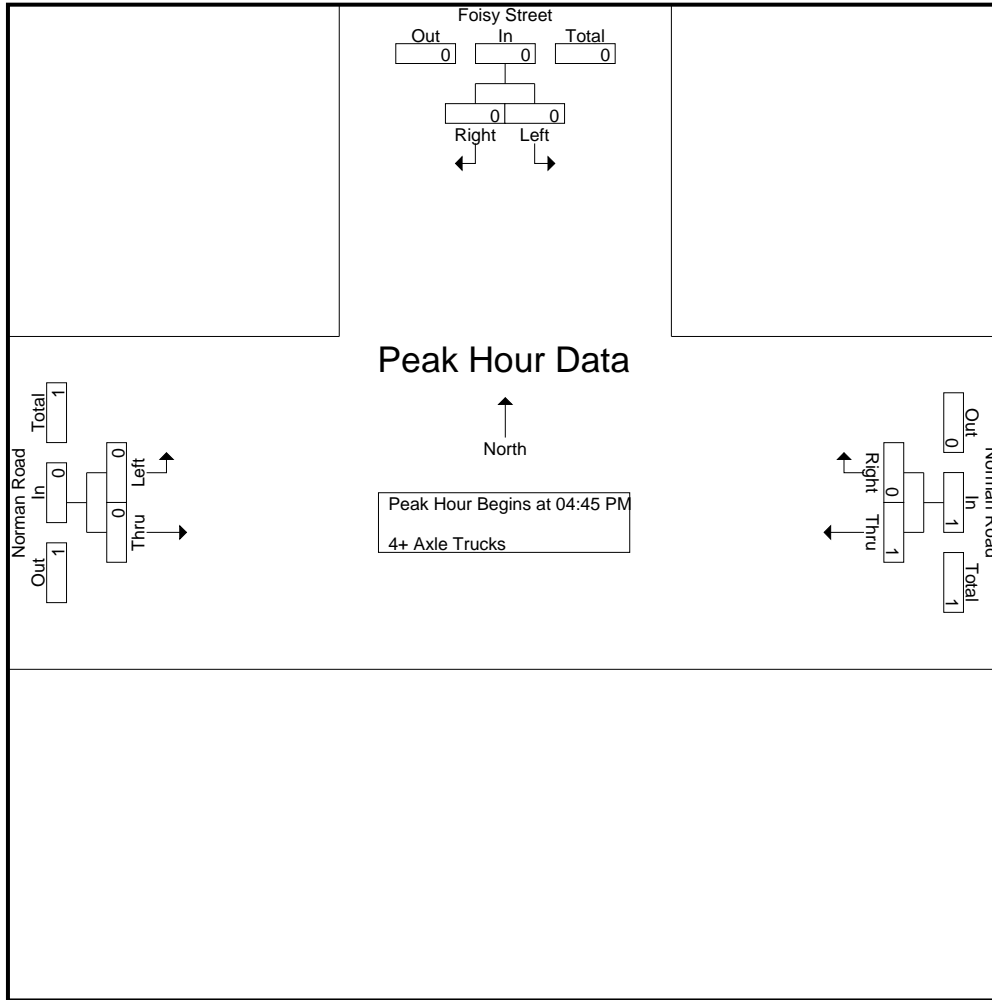

Peak Hour Analysis From 04:45 PM to 05:30 PM - Peak 1 of 1
 Peak Hour for Each Approach Begins at:

	04:45 PM			04:45 PM			04:45 PM		
+0 mins.	0	0	0	0	0	0	0	0	0
+15 mins.	0	0	0	0	0	0	0	0	0
+30 mins.	0	0	0	1	0	1	0	0	0
+45 mins.	0	0	0	0	0	0	0	0	0
Total Volume	0	0	0	1	0	1	0	0	0
% App. Total	0	0	0	100	0	100	0	0	0
PHF	.000	.000	.000	.250	.000	.250	.000	.000	.000

City of San Bernardino
 N/S: Valley View Ave/Lena Road
 E/W: Central Avenue
 Weather: Clear

File Name : 01_SBC_Lena_Central AM
 Site Code : 99921278
 Start Date : 6/15/2021
 Page No : 1

Groups Printed- Passenger Vehicles - Large 2 Axle Vehicles - 3 Axle Vehicles - 4+ Axle Trucks

Start Time	Valley View Avenue Southbound				Central Avenue Westbound				Lena Road Northbound				Central Avenue Eastbound				Int. Total
	Left	Thru	Right	App. Total	Left	Thru	Right	App. Total	Left	Thru	Right	App. Total	Left	Thru	Right	App. Total	
07:00 AM	0	6	3	9	2	35	2	39	1	9	14	24	0	33	3	36	108
07:15 AM	1	4	4	9	1	38	2	41	5	7	5	17	0	48	0	48	115
07:30 AM	2	0	2	4	7	40	3	50	3	7	15	25	4	32	1	37	116
07:45 AM	0	3	1	4	6	38	1	45	2	9	23	34	2	34	0	36	119
Total	3	13	10	26	16	151	8	175	11	32	57	100	6	147	4	157	458
08:00 AM	3	3	3	9	6	39	2	47	3	7	14	24	2	35	3	40	120
08:15 AM	1	5	2	8	3	44	1	48	4	5	7	16	4	26	4	34	106
08:30 AM	1	4	3	8	4	35	2	41	4	5	8	17	3	25	5	33	99
08:45 AM	1	7	2	10	8	49	1	58	1	3	7	11	2	17	5	24	103
Total	6	19	10	35	21	167	6	194	12	20	36	68	11	103	17	131	428
Grand Total	9	32	20	61	37	318	14	369	23	52	93	168	17	250	21	288	886
Apprch %	14.8	52.5	32.8		10	86.2	3.8		13.7	31	55.4		5.9	86.8	7.3		
Total %	1	3.6	2.3	6.9	4.2	35.9	1.6	41.6	2.6	5.9	10.5	19	1.9	28.2	2.4	32.5	
Passenger Vehicles	9	32	19	60	32	274	13	319	17	50	76	143	16	236	17	269	791
% Passenger Vehicles	100	100	95	98.4	86.5	86.2	92.9	86.4	73.9	96.2	81.7	85.1	94.1	94.4	81	93.4	89.3
Large 2 Axle Vehicles	0	0	0	0	0	12	1	13	0	0	2	2	0	2	1	3	18
% Large 2 Axle Vehicles	0	0	0	0	0	3.8	7.1	3.5	0	0	2.2	1.2	0	0.8	4.8	1	2
3 Axle Vehicles	0	0	0	0	0	12	0	12	2	0	6	8	0	6	1	7	27
% 3 Axle Vehicles	0	0	0	0	0	3.8	0	3.3	8.7	0	6.5	4.8	0	2.4	4.8	2.4	3
4+ Axle Trucks	0	0	1	1	5	20	0	25	4	2	9	15	1	6	2	9	50
% 4+ Axle Trucks	0	0	5	1.6	13.5	6.3	0	6.8	17.4	3.8	9.7	8.9	5.9	2.4	9.5	3.1	5.6

Start Time	Valley View Avenue Southbound				Central Avenue Westbound				Lena Road Northbound				Central Avenue Eastbound				Int. Total
	Left	Thru	Right	App. Total	Left	Thru	Right	App. Total	Left	Thru	Right	App. Total	Left	Thru	Right	App. Total	
Peak Hour Analysis From 07:00 AM to 08:45 AM - Peak 1 of 1																	
Peak Hour for Entire Intersection Begins at 07:15 AM																	
07:15 AM	1	4	4	9	1	38	2	41	5	7	5	17	0	48	0	48	115
07:30 AM	2	0	2	4	7	40	3	50	3	7	15	25	4	32	1	37	116
07:45 AM	0	3	1	4	6	38	1	45	2	9	23	34	2	34	0	36	119
08:00 AM	3	3	3	9	6	39	2	47	3	7	14	24	2	35	3	40	120
Total Volume	6	10	10	26	20	155	8	183	13	30	57	100	8	149	4	161	470
% App. Total	23.1	38.5	38.5		10.9	84.7	4.4		13	30	57		5	92.5	2.5		
PHF	.500	.625	.625	.722	.714	.969	.667	.915	.650	.833	.620	.735	.500	.776	.333	.839	.979

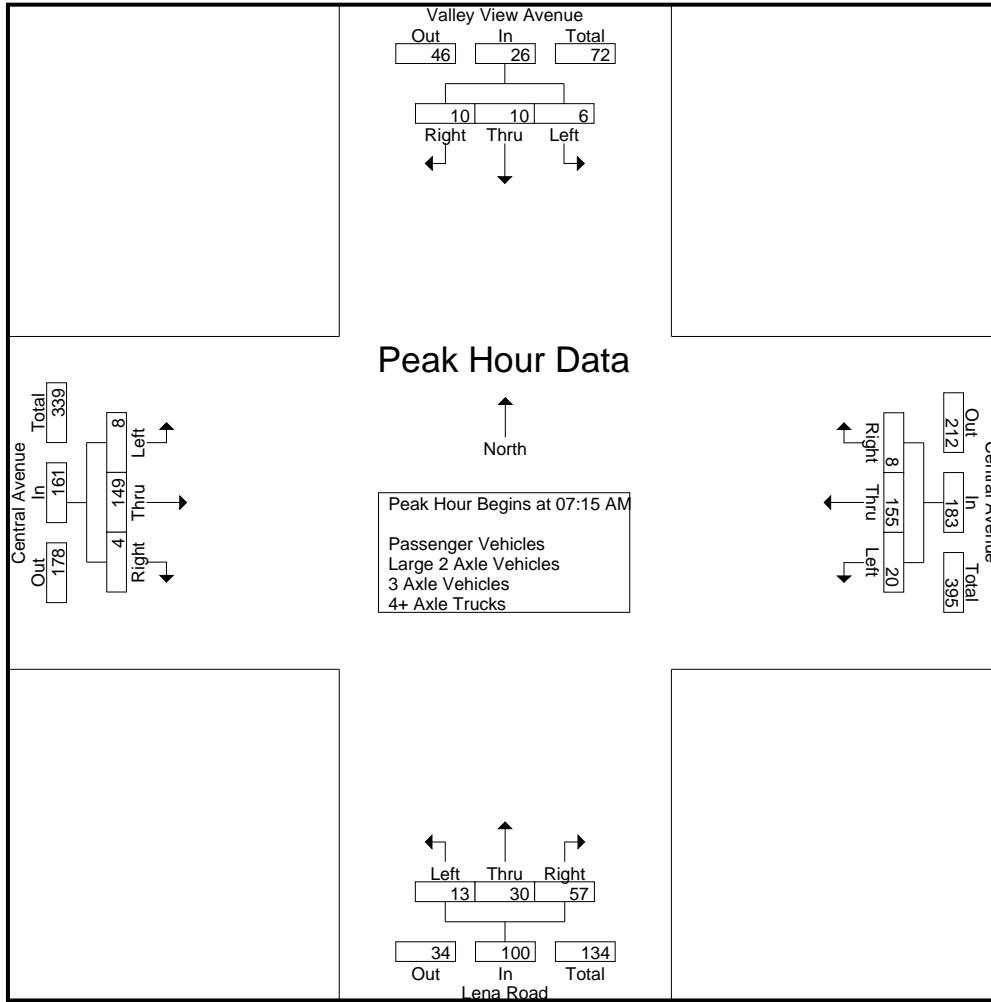

Peak Hour Analysis From 07:00 AM to 08:45 AM - Peak 1 of 1
 Peak Hour for Each Approach Begins at:

	08:00 AM				08:00 AM				07:00 AM				07:15 AM			
+0 mins.	3	3	3	9	6	39	2	47	1	9	14	24	0	48	0	48
+15 mins.	1	5	2	8	3	44	1	48	5	7	5	17	4	32	1	37
+30 mins.	1	4	3	8	4	35	2	41	3	7	15	25	2	34	0	36
+45 mins.	1	7	2	10	8	49	1	58	2	9	23	34	2	35	3	40
Total Volume	6	19	10	35	21	167	6	194	11	32	57	100	8	149	4	161
% App. Total	17.1	54.3	28.6		10.8	86.1	3.1		11	32	57		5	92.5	2.5	
PHF	.500	.679	.833	.875	.656	.852	.750	.836	.550	.889	.620	.735	.500	.776	.333	.839

City of San Bernardino
 N/S: Valley View Ave/Lena Road
 E/W: Central Avenue
 Weather: Clear

File Name : 01_SBC_Lena_Central AM
 Site Code : 99921278
 Start Date : 6/15/2021
 Page No : 1

Groups Printed- Passenger Vehicles

Start Time	Valley View Avenue Southbound				Central Avenue Westbound				Lena Road Northbound				Central Avenue Eastbound				Int. Total
	Left	Thru	Right	App. Total	Left	Thru	Right	App. Total	Left	Thru	Right	App. Total	Left	Thru	Right	App. Total	
07:00 AM	0	6	3	9	2	30	1	33	1	8	12	21	0	29	3	32	95
07:15 AM	1	4	4	9	1	30	2	33	5	7	4	16	0	47	0	47	105
07:30 AM	2	0	2	4	7	37	3	47	2	7	13	22	4	30	1	35	108
07:45 AM	0	3	1	4	6	34	1	41	2	8	20	30	2	32	0	34	109
Total	3	13	10	26	16	131	7	154	10	30	49	89	6	138	4	148	417
08:00 AM	3	3	3	9	3	33	2	38	2	7	11	20	2	34	2	38	105
08:15 AM	1	5	1	7	2	41	1	44	3	5	6	14	3	24	3	30	95
08:30 AM	1	4	3	8	4	25	2	31	1	5	6	12	3	24	5	32	83
08:45 AM	1	7	2	10	7	44	1	52	1	3	4	8	2	16	3	21	91
Total	6	19	9	34	16	143	6	165	7	20	27	54	10	98	13	121	374
Grand Total	9	32	19	60	32	274	13	319	17	50	76	143	16	236	17	269	791
Apprch %	15	53.3	31.7		10	85.9	4.1		11.9	35	53.1		5.9	87.7	6.3		
Total %	1.1	4	2.4	7.6	4	34.6	1.6	40.3	2.1	6.3	9.6	18.1	2	29.8	2.1	34	

Start Time	Valley View Avenue Southbound				Central Avenue Westbound				Lena Road Northbound				Central Avenue Eastbound				Int. Total
	Left	Thru	Right	App. Total	Left	Thru	Right	App. Total	Left	Thru	Right	App. Total	Left	Thru	Right	App. Total	
07:15 AM	1	4	4	9	1	30	2	33	5	7	4	16	0	47	0	47	105
07:30 AM	2	0	2	4	7	37	3	47	2	7	13	22	4	30	1	35	108
07:45 AM	0	3	1	4	6	34	1	41	2	8	20	30	2	32	0	34	109
08:00 AM	3	3	3	9	3	33	2	38	2	7	11	20	2	34	2	38	105
Total Volume	6	10	10	26	17	134	8	159	11	29	48	88	8	143	3	154	427
% App. Total	23.1	38.5	38.5		10.7	84.3	5		12.5	33	54.5		5.2	92.9	1.9		
PHF	.500	.625	.625	.722	.607	.905	.667	.846	.550	.906	.600	.733	.500	.761	.375	.819	.979

Peak Hour Analysis From 07:15 AM to 08:00 AM - Peak 1 of 1
 Peak Hour for Entire Intersection Begins at 07:15 AM

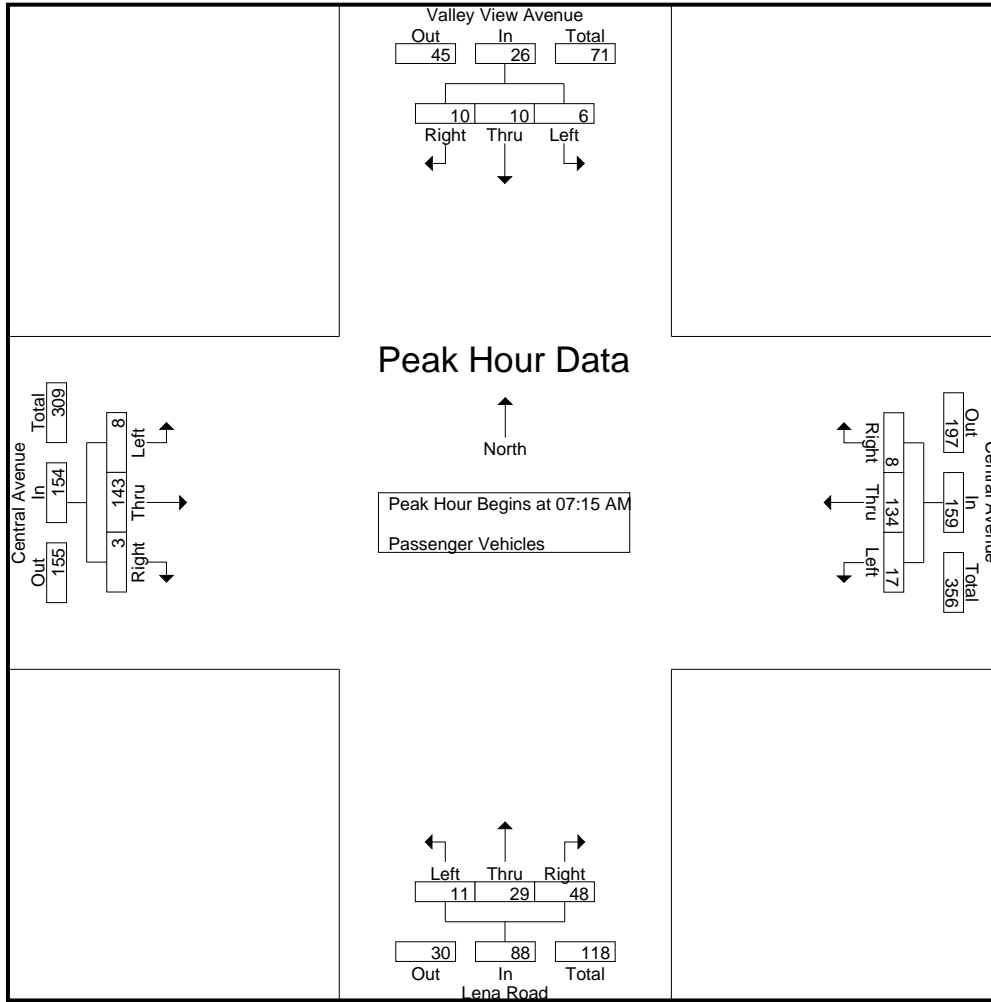

Peak Hour Analysis From 07:15 AM to 08:00 AM - Peak 1 of 1
 Peak Hour for Each Approach Begins at:

	07:15 AM				07:15 AM				07:15 AM				07:15 AM			
+0 mins.	1	4	4	9	1	30	2	33	5	7	4	16	0	47	0	47
+15 mins.	2	0	2	4	7	37	3	47	2	7	13	22	4	30	1	35
+30 mins.	0	3	1	4	6	34	1	41	2	8	20	30	2	32	0	34
+45 mins.	3	3	3	9	3	33	2	38	2	7	11	20	2	34	2	38
Total Volume	6	10	10	26	17	134	8	159	11	29	48	88	8	143	3	154
% App. Total	23.1	38.5	38.5		10.7	84.3	5		12.5	33	54.5		5.2	92.9	1.9	
PHF	.500	.625	.625	.722	.607	.905	.667	.846	.550	.906	.600	.733	.500	.761	.375	.819

City of San Bernardino
 N/S: Valley View Ave/Lena Road
 E/W: Central Avenue
 Weather: Clear

File Name : 01_SBC_Lena_Central AM
 Site Code : 99921278
 Start Date : 6/15/2021
 Page No : 1

Groups Printed- Large 2 Axle Vehicles

Start Time	Valley View Avenue Southbound				Central Avenue Westbound				Lena Road Northbound				Central Avenue Eastbound				Int. Total
	Left	Thru	Right	App. Total	Left	Thru	Right	App. Total	Left	Thru	Right	App. Total	Left	Thru	Right	App. Total	
07:00 AM	0	0	0	0	0	1	1	2	0	0	0	0	0	0	0	0	2
07:15 AM	0	0	0	0	0	1	0	1	0	0	1	1	0	0	0	0	2
07:30 AM	0	0	0	0	0	0	0	0	0	0	1	1	0	0	0	0	1
07:45 AM	0	0	0	0	0	0	0	0	0	0	0	0	0	1	0	1	1
Total	0	0	0	0	0	2	1	3	0	0	2	2	0	1	0	1	6
08:00 AM	0	0	0	0	0	2	0	2	0	0	0	0	0	0	0	0	2
08:15 AM	0	0	0	0	0	2	0	2	0	0	0	0	0	1	1	2	4
08:30 AM	0	0	0	0	0	6	0	6	0	0	0	0	0	0	0	0	6
08:45 AM	0	0	0	0	0	0	0	0	0	0	0	0	0	0	0	0	0
Total	0	0	0	0	0	10	0	10	0	0	0	0	0	1	1	2	12
Grand Total	0	0	0	0	0	12	1	13	0	0	2	2	0	2	1	3	18
Apprch %	0	0	0		0	92.3	7.7		0	0	100		0	66.7	33.3		
Total %	0	0	0		0	66.7	5.6	72.2	0	0	11.1	11.1	0	11.1	5.6	16.7	

Start Time	Valley View Avenue Southbound				Central Avenue Westbound				Lena Road Northbound				Central Avenue Eastbound				Int. Total
	Left	Thru	Right	App. Total	Left	Thru	Right	App. Total	Left	Thru	Right	App. Total	Left	Thru	Right	App. Total	
07:15 AM	0	0	0	0	0	1	0	1	0	0	1	1	0	0	0	0	2
07:30 AM	0	0	0	0	0	0	0	0	0	0	1	1	0	0	0	0	1
07:45 AM	0	0	0	0	0	0	0	0	0	0	0	0	0	1	0	1	1
08:00 AM	0	0	0	0	0	2	0	2	0	0	0	0	0	0	0	0	2
Total Volume	0	0	0	0	0	3	0	3	0	0	2	2	0	1	0	1	6
% App. Total	0	0	0		0	100	0		0	0	100		0	100	0		
PHF	.000	.000	.000	.000	.000	.375	.000	.375	.000	.000	.500	.500	.000	.250	.000	.250	.750

Peak Hour Analysis From 07:15 AM to 08:00 AM - Peak 1 of 1

Peak Hour for Entire Intersection Begins at 07:15 AM

City of San Bernardino
 N/S: Valley View Ave/Lena Road
 E/W: Central Avenue
 Weather: Clear

File Name : 01_SBC_Lena_Central AM
 Site Code : 99921278
 Start Date : 6/15/2021
 Page No : 2

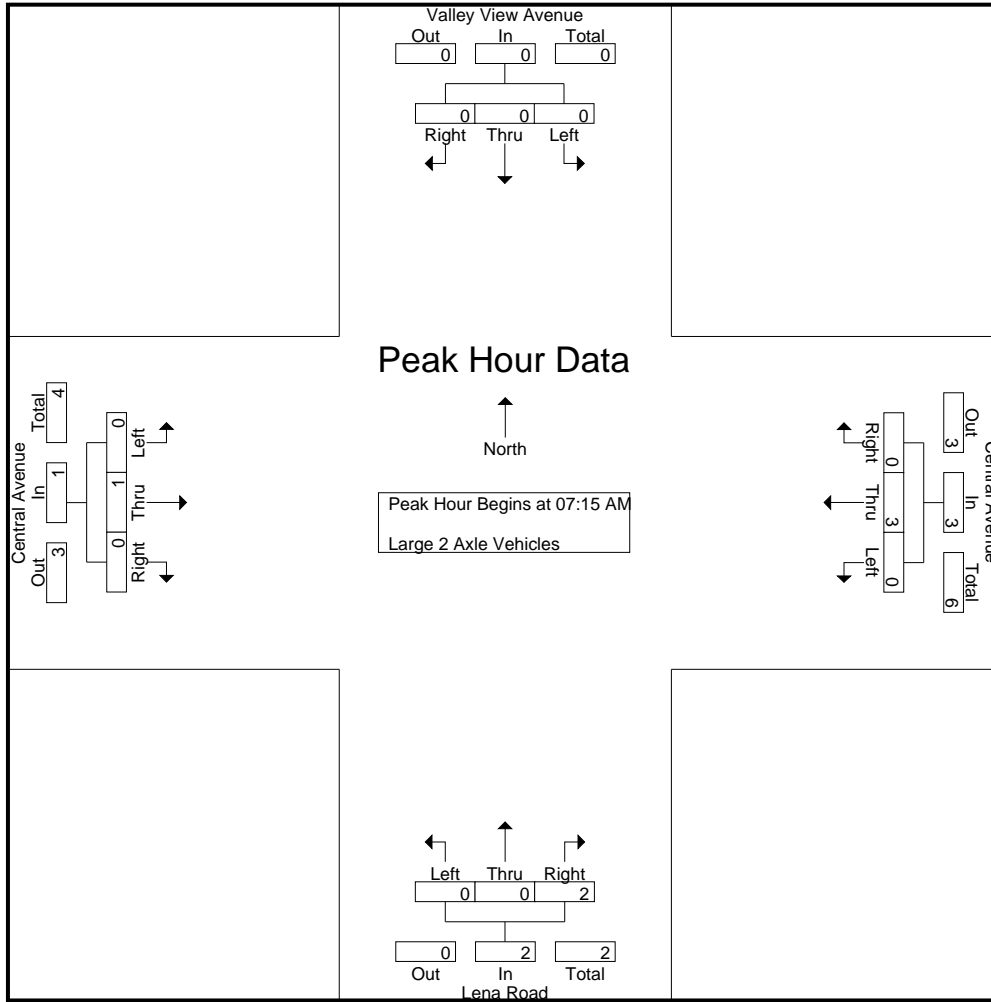

Peak Hour Analysis From 07:15 AM to 08:00 AM - Peak 1 of 1
 Peak Hour for Each Approach Begins at:

	07:15 AM				07:15 AM				07:15 AM				07:15 AM			
+0 mins.	0	0	0	0	0	1	0	1	0	0	1	1	0	0	0	0
+15 mins.	0	0	0	0	0	0	0	0	0	0	1	1	0	0	0	0
+30 mins.	0	0	0	0	0	0	0	0	0	0	0	0	0	1	0	1
+45 mins.	0	0	0	0	0	2	0	2	0	0	0	0	0	0	0	0
Total Volume	0	0	0	0	0	3	0	3	0	0	2	2	0	1	0	1
% App. Total	0	0	0	0	0	100	0	0	0	0	100	0	0	100	0	0
PHF	.000	.000	.000	.000	.000	.375	.000	.375	.000	.000	.500	.500	.000	.250	.000	.250

City of San Bernardino
 N/S: Valley View Ave/Lena Road
 E/W: Central Avenue
 Weather: Clear

File Name : 01_SBC_Lena_Central AM
 Site Code : 99921278
 Start Date : 6/15/2021
 Page No : 1

Groups Printed- 3 Axle Vehicles

Start Time	Valley View Avenue Southbound				Central Avenue Westbound				Lena Road Northbound				Central Avenue Eastbound				Int. Total
	Left	Thru	Right	App. Total	Left	Thru	Right	App. Total	Left	Thru	Right	App. Total	Left	Thru	Right	App. Total	
07:00 AM	0	0	0	0	0	2	0	2	0	0	2	2	0	2	0	2	6
07:15 AM	0	0	0	0	0	2	0	2	0	0	0	0	0	0	0	0	2
07:30 AM	0	0	0	0	0	1	0	1	0	0	0	0	0	1	0	1	2
07:45 AM	0	0	0	0	0	3	0	3	0	0	1	1	0	1	0	1	5
Total	0	0	0	0	0	8	0	8	0	0	3	3	0	4	0	4	15
08:00 AM	0	0	0	0	0	1	0	1	1	0	1	2	0	0	0	0	3
08:15 AM	0	0	0	0	0	1	0	1	1	0	1	2	0	1	0	1	4
08:30 AM	0	0	0	0	0	0	0	0	0	0	1	1	0	0	0	0	1
08:45 AM	0	0	0	0	0	2	0	2	0	0	0	0	0	1	1	2	4
Total	0	0	0	0	0	4	0	4	2	0	3	5	0	2	1	3	12
Grand Total	0	0	0	0	0	12	0	12	2	0	6	8	0	6	1	7	27
Apprch %	0	0	0		0	100	0		25	0	75		0	85.7	14.3		
Total %	0	0	0		0	44.4	0	44.4	7.4	0	22.2	29.6	0	22.2	3.7	25.9	

Start Time	Valley View Avenue Southbound				Central Avenue Westbound				Lena Road Northbound				Central Avenue Eastbound				Int. Total
	Left	Thru	Right	App. Total	Left	Thru	Right	App. Total	Left	Thru	Right	App. Total	Left	Thru	Right	App. Total	
07:15 AM	0	0	0	0	0	2	0	2	0	0	0	0	0	0	0	0	2
07:30 AM	0	0	0	0	0	1	0	1	0	0	0	0	0	1	0	1	2
07:45 AM	0	0	0	0	0	3	0	3	0	0	1	1	0	1	0	1	5
08:00 AM	0	0	0	0	0	1	0	1	1	0	1	2	0	0	0	0	3
Total Volume	0	0	0	0	0	7	0	7	1	0	2	3	0	2	0	2	12
% App. Total	0	0	0		0	100	0		33.3	0	66.7		0	100	0		
PHF	.000	.000	.000	.000	.000	.583	.000	.583	.250	.000	.500	.375	.000	.500	.000	.500	.600

Peak Hour Analysis From 07:15 AM to 08:00 AM - Peak 1 of 1

Peak Hour for Entire Intersection Begins at 07:15 AM

City of San Bernardino
 N/S: Valley View Ave/Lena Road
 E/W: Central Avenue
 Weather: Clear

File Name : 01_SBC_Lena_Central AM
 Site Code : 99921278
 Start Date : 6/15/2021
 Page No : 2

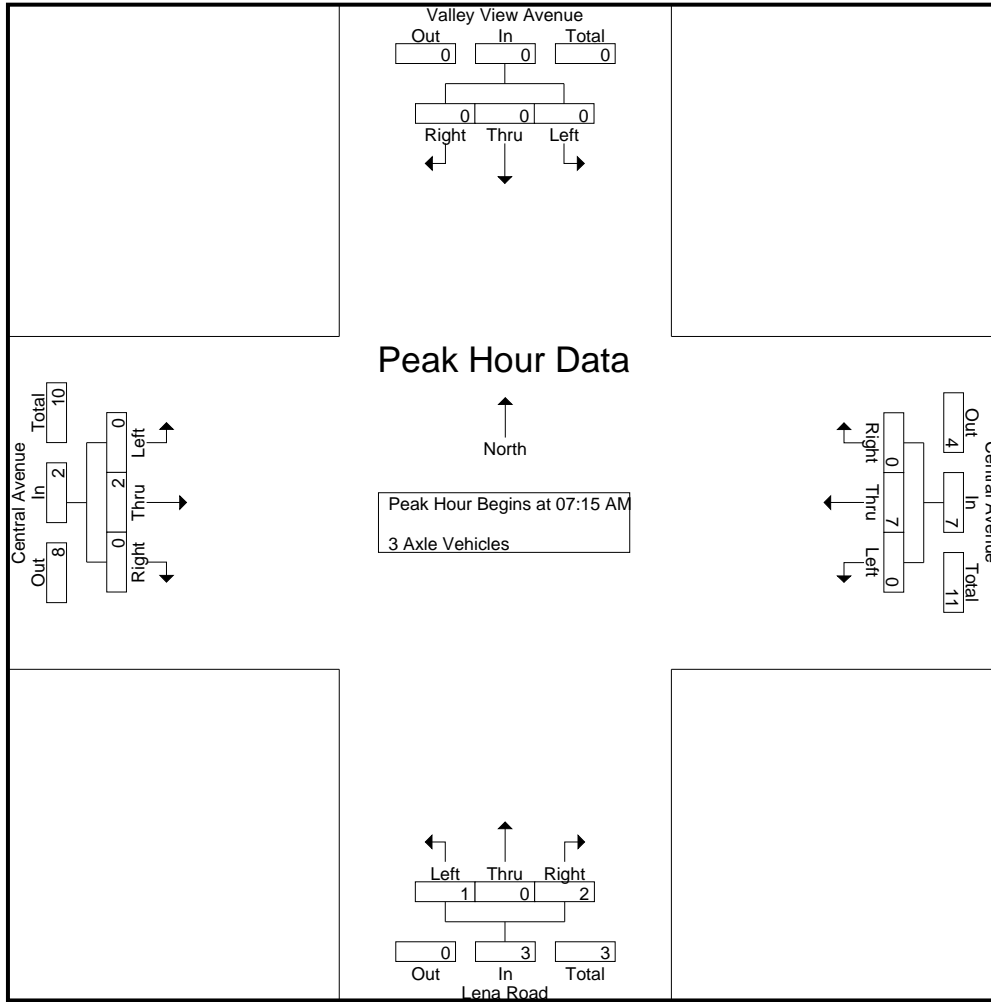

Peak Hour Analysis From 07:15 AM to 08:00 AM - Peak 1 of 1
 Peak Hour for Each Approach Begins at:

	07:15 AM				07:15 AM				07:15 AM				07:15 AM			
+0 mins.	0	0	0	0	0	2	0	2	0	0	0	0	0	0	0	0
+15 mins.	0	0	0	0	0	1	0	1	0	0	0	0	0	1	0	1
+30 mins.	0	0	0	0	0	3	0	3	0	0	1	1	0	1	0	1
+45 mins.	0	0	0	0	0	1	0	1	1	0	1	2	0	0	0	0
Total Volume	0	0	0	0	0	7	0	7	1	0	2	3	0	2	0	2
% App. Total	0	0	0	0	0	100	0	0	33.3	0	66.7	0	0	100	0	0
PHF	.000	.000	.000	.000	.000	.583	.000	.583	.250	.000	.500	.375	.000	.500	.000	.500

City of San Bernardino
 N/S: Valley View Ave/Lena Road
 E/W: Central Avenue
 Weather: Clear

File Name : 01_SBC_Lena_Central AM
 Site Code : 99921278
 Start Date : 6/15/2021
 Page No : 1

Groups Printed- 4+ Axle Trucks

Start Time	Valley View Avenue Southbound				Central Avenue Westbound				Lena Road Northbound				Central Avenue Eastbound				Int. Total
	Left	Thru	Right	App. Total	Left	Thru	Right	App. Total	Left	Thru	Right	App. Total	Left	Thru	Right	App. Total	
07:00 AM	0	0	0	0	0	2	0	2	0	1	0	1	0	2	0	2	5
07:15 AM	0	0	0	0	0	5	0	5	0	0	0	0	0	1	0	1	6
07:30 AM	0	0	0	0	0	2	0	2	1	0	1	2	0	1	0	1	5
07:45 AM	0	0	0	0	0	1	0	1	0	1	2	3	0	0	0	0	4
Total	0	0	0	0	0	10	0	10	1	2	3	6	0	4	0	4	20
08:00 AM	0	0	0	0	3	3	0	6	0	0	2	2	0	1	1	2	10
08:15 AM	0	0	1	1	1	0	0	1	0	0	0	0	1	0	0	1	3
08:30 AM	0	0	0	0	0	4	0	4	3	0	1	4	0	1	0	1	9
08:45 AM	0	0	0	0	1	3	0	4	0	0	3	3	0	0	1	1	8
Total	0	0	1	1	5	10	0	15	3	0	6	9	1	2	2	5	30
Grand Total	0	0	1	1	5	20	0	25	4	2	9	15	1	6	2	9	50
Apprch %	0	0	100		20	80	0		26.7	13.3	60		11.1	66.7	22.2		
Total %	0	0	2	2	10	40	0	50	8	4	18	30	2	12	4	18	

Start Time	Valley View Avenue Southbound				Central Avenue Westbound				Lena Road Northbound				Central Avenue Eastbound				Int. Total
	Left	Thru	Right	App. Total	Left	Thru	Right	App. Total	Left	Thru	Right	App. Total	Left	Thru	Right	App. Total	
07:15 AM	0	0	0	0	0	5	0	5	0	0	0	0	0	1	0	1	6
07:30 AM	0	0	0	0	0	2	0	2	1	0	1	2	0	1	0	1	5
07:45 AM	0	0	0	0	0	1	0	1	0	1	2	3	0	0	0	0	4
08:00 AM	0	0	0	0	3	3	0	6	0	0	2	2	0	1	1	2	10
Total Volume	0	0	0	0	3	11	0	14	1	1	5	7	0	3	1	4	25
% App. Total	0	0	0		21.4	78.6	0		14.3	14.3	71.4		0	75	25		
PHF	.000	.000	.000	.000	.250	.550	.000	.583	.250	.250	.625	.583	.000	.750	.250	.500	.625

Peak Hour Analysis From 07:15 AM to 08:00 AM - Peak 1 of 1
 Peak Hour for Entire Intersection Begins at 07:15 AM

City of San Bernardino
 N/S: Valley View Ave/Lena Road
 E/W: Central Avenue
 Weather: Clear

File Name : 01_SBC_Lena_Central AM
 Site Code : 99921278
 Start Date : 6/15/2021
 Page No : 2

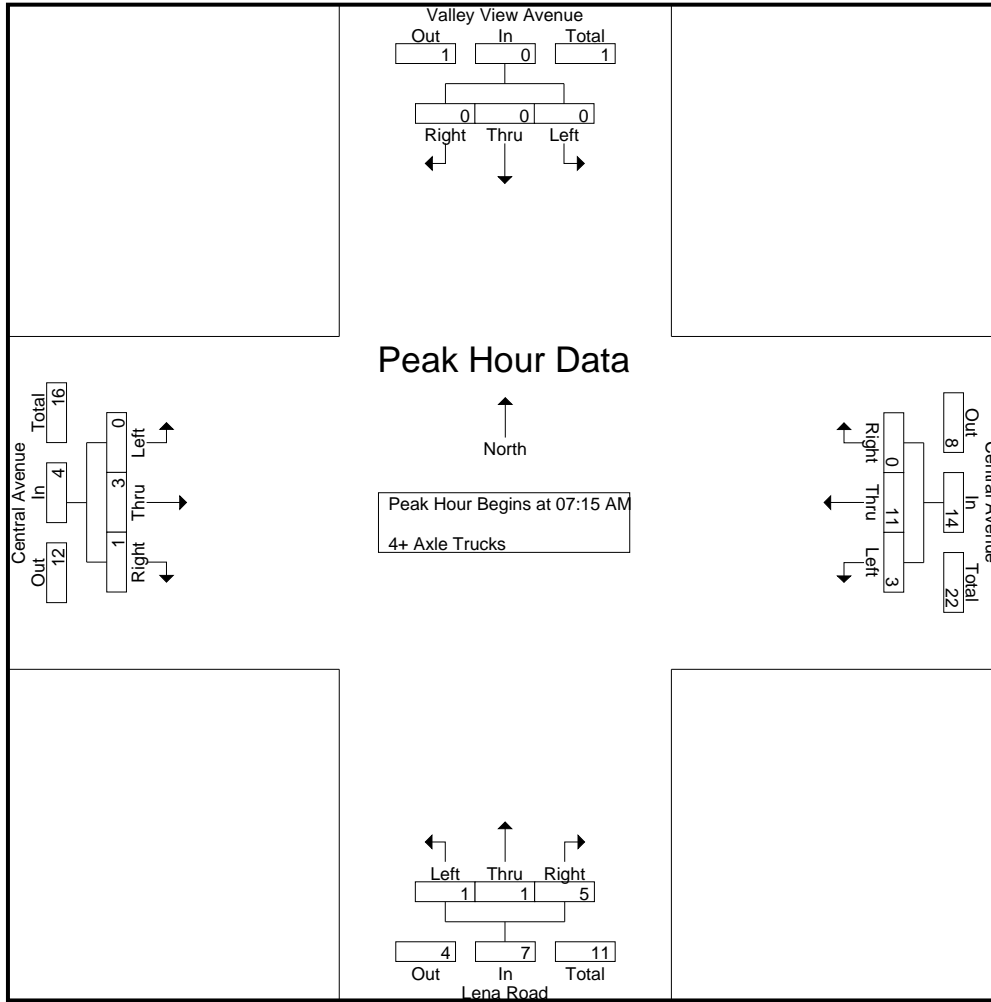

Peak Hour Analysis From 07:15 AM to 08:00 AM - Peak 1 of 1
 Peak Hour for Each Approach Begins at:

	07:15 AM				07:15 AM				07:15 AM				07:15 AM			
+0 mins.	0	0	0	0	0	5	0	5	0	0	0	0	0	1	0	1
+15 mins.	0	0	0	0	0	2	0	2	1	0	1	2	0	1	0	1
+30 mins.	0	0	0	0	0	1	0	1	0	1	2	3	0	0	0	0
+45 mins.	0	0	0	0	3	3	0	6	0	0	2	2	0	1	1	2
Total Volume	0	0	0	0	3	11	0	14	1	1	5	7	0	3	1	4
% App. Total	0	0	0	0	21.4	78.6	0		14.3	14.3	71.4		0	75	25	
PHF	.000	.000	.000	.000	.250	.550	.000	.583	.250	.250	.625	.583	.000	.750	.250	.500

City of San Bernardino
 N/S: Valley View Ave/Lena Road
 E/W: Central Avenue
 Weather: Clear

File Name : 01_SBC_Lena_Central PM
 Site Code : 99921278
 Start Date : 6/15/2021
 Page No : 1

Groups Printed- Passenger Vehicles - Large 2 Axle Vehicles - 3 Axle Vehicles - 4+ Axle Trucks

Start Time	Valley View Avenue Southbound				Central Avenue Westbound				Lena Road Northbound				Central Avenue Eastbound				Int. Total
	Left	Thru	Right	App. Total	Left	Thru	Right	App. Total	Left	Thru	Right	App. Total	Left	Thru	Right	App. Total	
04:00 PM	2	9	4	15	2	56	2	60	6	7	10	23	2	28	2	32	130
04:15 PM	2	5	2	9	2	45	2	49	1	3	8	12	1	29	4	34	104
04:30 PM	1	15	4	20	4	74	1	79	3	12	7	22	3	39	9	51	172
04:45 PM	6	4	4	14	1	49	3	53	7	9	11	27	2	52	4	58	152
Total	11	33	14	58	9	224	8	241	17	31	36	84	8	148	19	175	558
05:00 PM	1	11	0	12	7	53	1	61	4	11	6	21	3	39	3	45	139
05:15 PM	1	2	0	3	8	66	1	75	0	12	10	22	2	30	1	33	133
05:30 PM	3	6	2	11	9	80	1	90	7	4	11	22	1	32	0	33	156
05:45 PM	2	5	4	11	5	32	2	39	2	7	10	19	1	55	0	56	125
Total	7	24	6	37	29	231	5	265	13	34	37	84	7	156	4	167	553
Grand Total	18	57	20	95	38	455	13	506	30	65	73	168	15	304	23	342	1111
Apprch %	18.9	60	21.1		7.5	89.9	2.6		17.9	38.7	43.5		4.4	88.9	6.7		
Total %	1.6	5.1	1.8	8.6	3.4	41	1.2	45.5	2.7	5.9	6.6	15.1	1.4	27.4	2.1	30.8	
Passenger Vehicles	17	55	19	91	34	417	13	464	27	60	55	142	14	285	23	322	1019
% Passenger Vehicles	94.4	96.5	95	95.8	89.5	91.6	100	91.7	90	92.3	75.3	84.5	93.3	93.8	100	94.2	91.7
Large 2 Axle Vehicles	0	1	1	2	1	10	0	11	1	2	4	7	1	7	0	8	28
% Large 2 Axle Vehicles	0	1.8	5	2.1	2.6	2.2	0	2.2	3.3	3.1	5.5	4.2	6.7	2.3	0	2.3	2.5
3 Axle Vehicles	1	1	0	2	2	15	0	17	1	1	5	7	0	6	0	6	32
% 3 Axle Vehicles	5.6	1.8	0	2.1	5.3	3.3	0	3.4	3.3	1.5	6.8	4.2	0	2	0	1.8	2.9
4+ Axle Trucks	0	0	0	0	1	13	0	14	1	2	9	12	0	6	0	6	32
% 4+ Axle Trucks	0	0	0	0	2.6	2.9	0	2.8	3.3	3.1	12.3	7.1	0	2	0	1.8	2.9

Start Time	Valley View Avenue Southbound				Central Avenue Westbound				Lena Road Northbound				Central Avenue Eastbound				Int. Total
	Left	Thru	Right	App. Total	Left	Thru	Right	App. Total	Left	Thru	Right	App. Total	Left	Thru	Right	App. Total	
Peak Hour Analysis From 04:00 PM to 05:45 PM - Peak 1 of 1																	
Peak Hour for Entire Intersection Begins at 04:30 PM																	
04:30 PM	1	15	4	20	4	74	1	79	3	12	7	22	3	39	9	51	172
04:45 PM	6	4	4	14	1	49	3	53	7	9	11	27	2	52	4	58	152
05:00 PM	1	11	0	12	7	53	1	61	4	11	6	21	3	39	3	45	139
05:15 PM	1	2	0	3	8	66	1	75	0	12	10	22	2	30	1	33	133
Total Volume	9	32	8	49	20	242	6	268	14	44	34	92	10	160	17	187	596
% App. Total	18.4	65.3	16.3		7.5	90.3	2.2		15.2	47.8	37		5.3	85.6	9.1		
PHF	.375	.533	.500	.613	.625	.818	.500	.848	.500	.917	.773	.852	.833	.769	.472	.806	.866

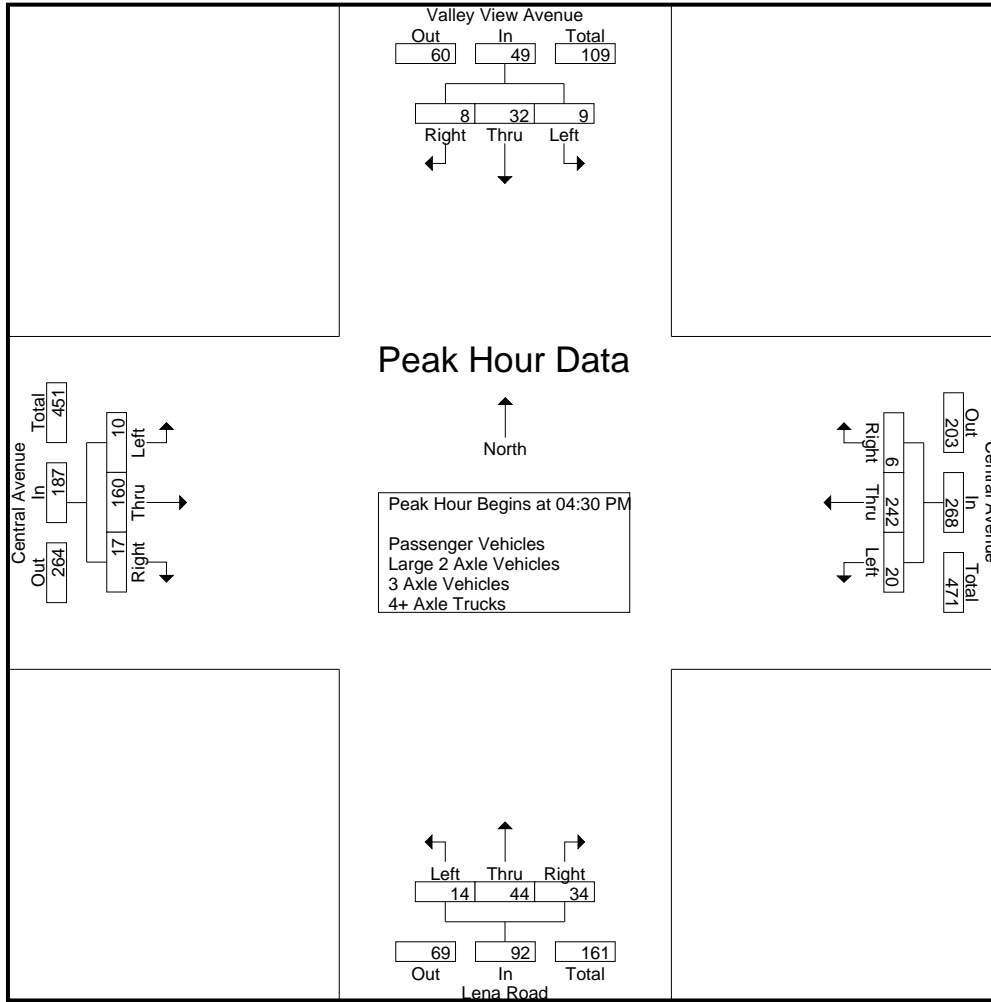

Peak Hour Analysis From 04:00 PM to 05:45 PM - Peak 1 of 1
 Peak Hour for Each Approach Begins at:

	04:00 PM				04:45 PM				04:30 PM				04:15 PM			
+0 mins.	2	9	4	15	1	49	3	53	3	12	7	22	1	29	4	34
+15 mins.	2	5	2	9	7	53	1	61	7	9	11	27	3	39	9	51
+30 mins.	1	15	4	20	8	66	1	75	4	11	6	21	2	52	4	58
+45 mins.	6	4	4	14	9	80	1	90	0	12	10	22	3	39	3	45
Total Volume	11	33	14	58	25	248	6	279	14	44	34	92	9	159	20	188
% App. Total	19	56.9	24.1		9	88.9	2.2		15.2	47.8	37		4.8	84.6	10.6	
PHF	.458	.550	.875	.725	.694	.775	.500	.775	.500	.917	.773	.852	.750	.764	.556	.810

City of San Bernardino
 N/S: Valley View Ave/Lena Road
 E/W: Central Avenue
 Weather: Clear

File Name : 01_SBC_Lena_Central PM
 Site Code : 99921278
 Start Date : 6/15/2021
 Page No : 1

Groups Printed- Passenger Vehicles

Start Time	Valley View Avenue Southbound				Central Avenue Westbound				Lena Road Northbound				Central Avenue Eastbound				Int. Total
	Left	Thru	Right	App. Total	Left	Thru	Right	App. Total	Left	Thru	Right	App. Total	Left	Thru	Right	App. Total	
04:00 PM	2	9	4	15	1	48	2	51	5	6	7	18	1	28	2	31	115
04:15 PM	1	5	2	8	2	39	2	43	1	3	5	9	1	24	4	29	89
04:30 PM	1	14	4	19	4	67	1	72	3	12	5	20	3	39	9	51	162
04:45 PM	6	4	3	13	1	45	3	49	6	8	9	23	2	47	4	53	138
Total	10	32	13	55	8	199	8	215	15	29	26	70	7	138	19	164	504
05:00 PM	1	11	0	12	6	48	1	55	4	11	5	20	3	38	3	44	131
05:15 PM	1	2	0	3	8	64	1	73	0	11	8	19	2	27	1	30	125
05:30 PM	3	5	2	10	8	76	1	85	6	2	8	16	1	30	0	31	142
05:45 PM	2	5	4	11	4	30	2	36	2	7	8	17	1	52	0	53	117
Total	7	23	6	36	26	218	5	249	12	31	29	72	7	147	4	158	515
Grand Total	17	55	19	91	34	417	13	464	27	60	55	142	14	285	23	322	1019
Apprch %	18.7	60.4	20.9		7.3	89.9	2.8		19	42.3	38.7		4.3	88.5	7.1		
Total %	1.7	5.4	1.9	8.9	3.3	40.9	1.3	45.5	2.6	5.9	5.4	13.9	1.4	28	2.3	31.6	

Start Time	Valley View Avenue Southbound				Central Avenue Westbound				Lena Road Northbound				Central Avenue Eastbound				Int. Total
	Left	Thru	Right	App. Total	Left	Thru	Right	App. Total	Left	Thru	Right	App. Total	Left	Thru	Right	App. Total	
04:30 PM	1	14	4	19	4	67	1	72	3	12	5	20	3	39	9	51	162
04:45 PM	6	4	3	13	1	45	3	49	6	8	9	23	2	47	4	53	138
05:00 PM	1	11	0	12	6	48	1	55	4	11	5	20	3	38	3	44	131
05:15 PM	1	2	0	3	8	64	1	73	0	11	8	19	2	27	1	30	125
Total Volume	9	31	7	47	19	224	6	249	13	42	27	82	10	151	17	178	556
% App. Total	19.1	66	14.9		7.6	90	2.4		15.9	51.2	32.9		5.6	84.8	9.6		
PHF	.375	.554	.438	.618	.594	.836	.500	.853	.542	.875	.750	.891	.833	.803	.472	.840	.858

Peak Hour Analysis From 04:30 PM to 05:15 PM - Peak 1 of 1
 Peak Hour for Entire Intersection Begins at 04:30 PM

City of San Bernardino
 N/S: Valley View Ave/Lena Road
 E/W: Central Avenue
 Weather: Clear

File Name : 01_SBC_Lena_Central PM
 Site Code : 99921278
 Start Date : 6/15/2021
 Page No : 2

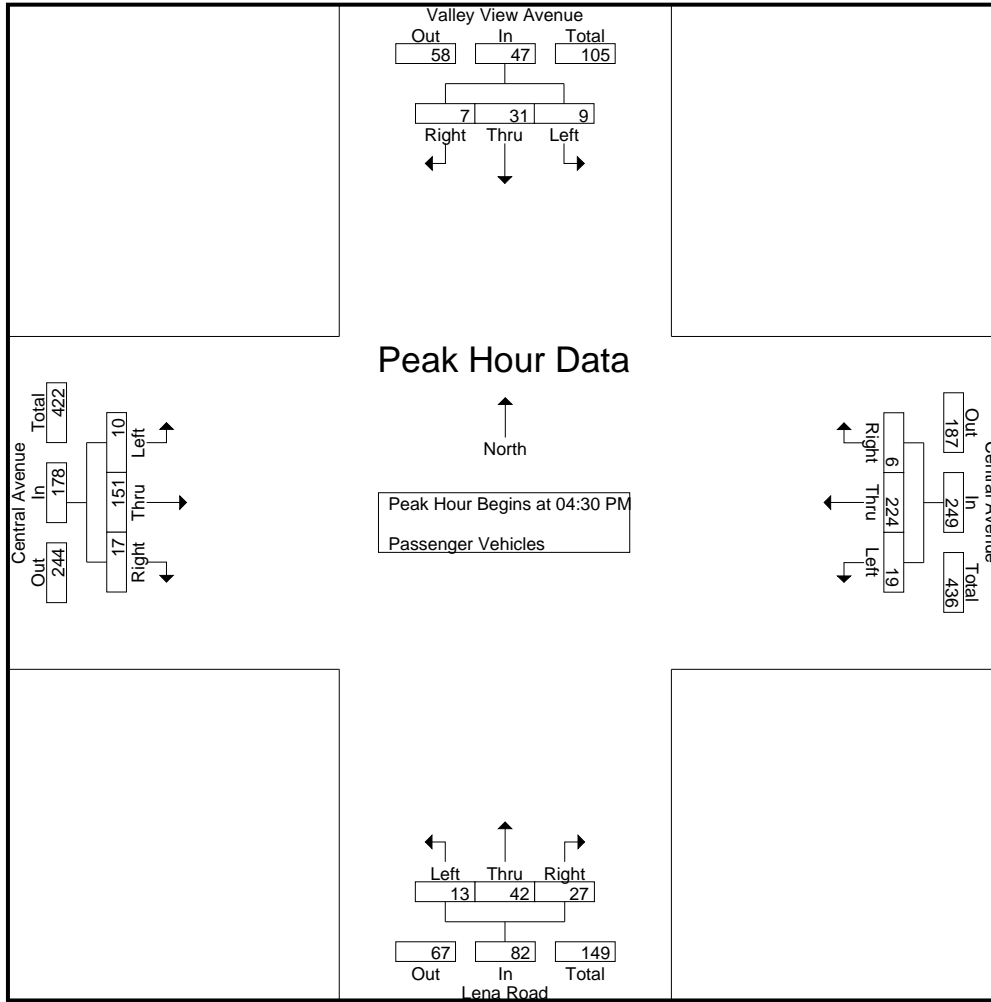

Peak Hour Analysis From 04:30 PM to 05:15 PM - Peak 1 of 1
 Peak Hour for Each Approach Begins at:

	04:30 PM				04:30 PM				04:30 PM				04:30 PM			
+0 mins.	1	14	4	19	4	67	1	72	3	12	5	20	3	39	9	51
+15 mins.	6	4	3	13	1	45	3	49	6	8	9	23	2	47	4	53
+30 mins.	1	11	0	12	6	48	1	55	4	11	5	20	3	38	3	44
+45 mins.	1	2	0	3	8	64	1	73	0	11	8	19	2	27	1	30
Total Volume	9	31	7	47	19	224	6	249	13	42	27	82	10	151	17	178
% App. Total	19.1	66	14.9		7.6	90	2.4		15.9	51.2	32.9		5.6	84.8	9.6	
PHF	.375	.554	.438	.618	.594	.836	.500	.853	.542	.875	.750	.891	.833	.803	.472	.840

City of San Bernardino
 N/S: Valley View Ave/Lena Road
 E/W: Central Avenue
 Weather: Clear

File Name : 01_SBC_Lena_Central PM
 Site Code : 99921278
 Start Date : 6/15/2021
 Page No : 1

Groups Printed- Large 2 Axle Vehicles

Start Time	Valley View Avenue Southbound				Central Avenue Westbound				Lena Road Northbound				Central Avenue Eastbound				Int. Total
	Left	Thru	Right	App. Total	Left	Thru	Right	App. Total	Left	Thru	Right	App. Total	Left	Thru	Right	App. Total	
04:00 PM	0	0	0	0	1	3	0	4	0	0	0	0	1	0	0	1	5
04:15 PM	0	0	0	0	0	1	0	1	0	0	0	0	0	1	0	1	2
04:30 PM	0	1	0	1	0	2	0	2	0	0	1	1	0	0	0	0	4
04:45 PM	0	0	1	1	0	0	0	0	1	1	0	2	0	2	0	2	5
Total	0	1	1	2	1	6	0	7	1	1	1	3	1	3	0	4	16
05:00 PM	0	0	0	0	0	2	0	2	0	0	0	0	0	0	0	0	2
05:15 PM	0	0	0	0	0	0	0	0	0	1	2	3	0	1	0	1	4
05:30 PM	0	0	0	0	0	2	0	2	0	0	1	1	0	2	0	2	5
05:45 PM	0	0	0	0	0	0	0	0	0	0	0	0	0	1	0	1	1
Total	0	0	0	0	0	4	0	4	0	1	3	4	0	4	0	4	12
Grand Total	0	1	1	2	1	10	0	11	1	2	4	7	1	7	0	8	28
Apprch %	0	50	50		9.1	90.9	0		14.3	28.6	57.1		12.5	87.5	0		
Total %	0	3.6	3.6	7.1	3.6	35.7	0	39.3	3.6	7.1	14.3	25	3.6	25	0	28.6	

Start Time	Valley View Avenue Southbound				Central Avenue Westbound				Lena Road Northbound				Central Avenue Eastbound				Int. Total
	Left	Thru	Right	App. Total	Left	Thru	Right	App. Total	Left	Thru	Right	App. Total	Left	Thru	Right	App. Total	
04:30 PM	0	1	0	1	0	2	0	2	0	0	1	1	0	0	0	0	4
04:45 PM	0	0	1	1	0	0	0	0	1	1	0	2	0	2	0	2	5
05:00 PM	0	0	0	0	0	2	0	2	0	0	0	0	0	0	0	0	2
05:15 PM	0	0	0	0	0	0	0	0	0	1	2	3	0	1	0	1	4
Total Volume	0	1	1	2	0	4	0	4	1	2	3	6	0	3	0	3	15
% App. Total	0	50	50		0	100	0		16.7	33.3	50		0	100	0		
PHF	.000	.250	.250	.500	.000	.500	.000	.500	.250	.500	.375	.500	.000	.375	.000	.375	.750

Peak Hour Analysis From 04:30 PM to 05:15 PM - Peak 1 of 1
 Peak Hour for Entire Intersection Begins at 04:30 PM

City of San Bernardino
 N/S: Valley View Ave/Lena Road
 E/W: Central Avenue
 Weather: Clear

File Name : 01_SBC_Lena_Central PM
 Site Code : 99921278
 Start Date : 6/15/2021
 Page No : 2

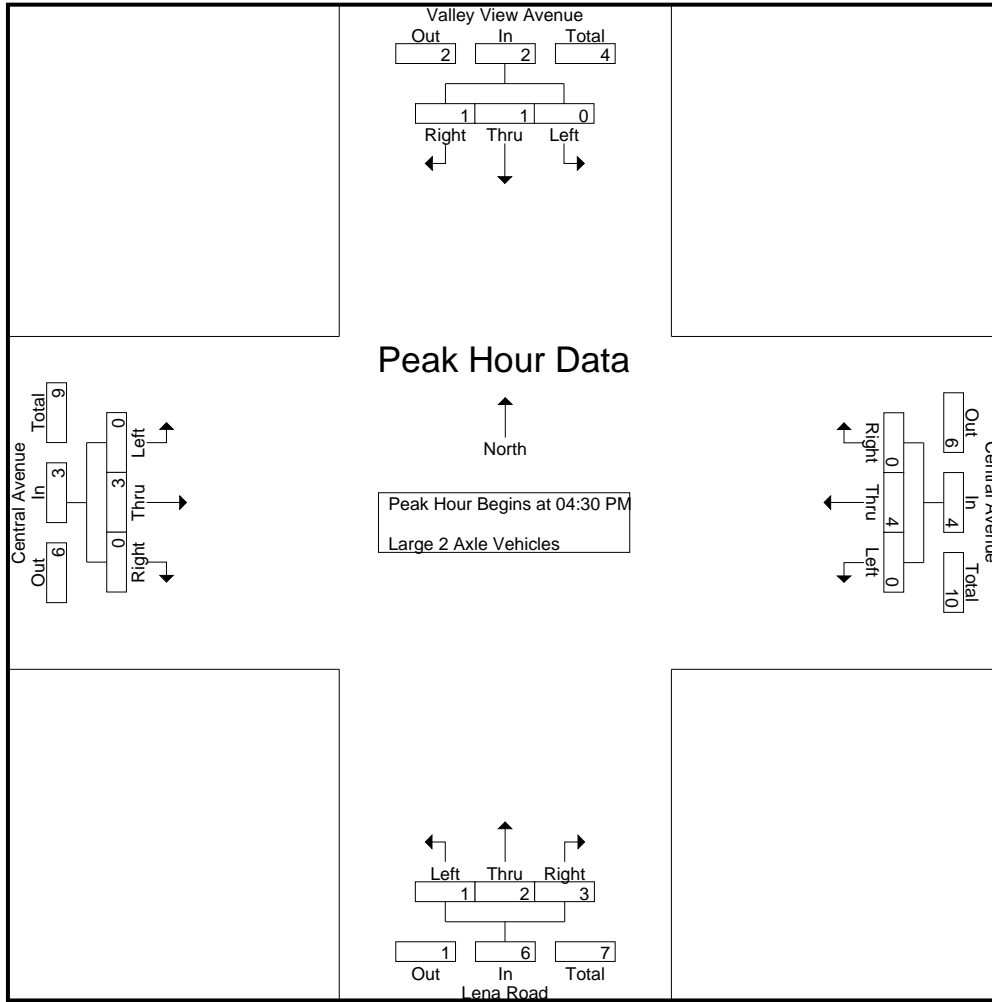

Peak Hour Analysis From 04:30 PM to 05:15 PM - Peak 1 of 1
 Peak Hour for Each Approach Begins at:

	04:30 PM				04:30 PM				04:30 PM				04:30 PM			
+0 mins.	0	1	0	1	0	2	0	2	0	0	1	1	0	0	0	0
+15 mins.	0	0	1	1	0	0	0	0	1	1	0	2	0	2	0	2
+30 mins.	0	0	0	0	0	2	0	2	0	0	0	0	0	0	0	0
+45 mins.	0	0	0	0	0	0	0	0	0	1	2	3	0	1	0	1
Total Volume	0	1	1	2	0	4	0	4	1	2	3	6	0	3	0	3
% App. Total	0	50	50		0	100	0		16.7	33.3	50		0	100	0	
PHF	.000	.250	.250	.500	.000	.500	.000	.500	.250	.500	.375	.500	.000	.375	.000	.375

City of San Bernardino
 N/S: Valley View Ave/Lena Road
 E/W: Central Avenue
 Weather: Clear

File Name : 01_SBC_Lena_Central PM
 Site Code : 99921278
 Start Date : 6/15/2021
 Page No : 1

Groups Printed- 3 Axle Vehicles

Start Time	Valley View Avenue Southbound				Central Avenue Westbound				Lena Road Northbound				Central Avenue Eastbound				Int. Total
	Left	Thru	Right	App. Total	Left	Thru	Right	App. Total	Left	Thru	Right	App. Total	Left	Thru	Right	App. Total	
04:00 PM	0	0	0	0	0	2	0	2	0	1	0	1	0	0	0	0	3
04:15 PM	1	0	0	1	0	1	0	1	0	0	2	2	0	2	0	2	6
04:30 PM	0	0	0	0	0	5	0	5	0	0	0	0	0	0	0	0	5
04:45 PM	0	0	0	0	0	2	0	2	0	0	1	1	0	2	0	2	5
Total	1	0	0	1	0	10	0	10	0	1	3	4	0	4	0	4	19
05:00 PM	0	0	0	0	1	2	0	3	0	0	0	0	0	0	0	0	3
05:15 PM	0	0	0	0	0	1	0	1	0	0	0	0	0	1	0	1	2
05:30 PM	0	1	0	1	0	1	0	1	1	0	0	1	0	0	0	0	3
05:45 PM	0	0	0	0	1	1	0	2	0	0	2	2	0	1	0	1	5
Total	0	1	0	1	2	5	0	7	1	0	2	3	0	2	0	2	13
Grand Total	1	1	0	2	2	15	0	17	1	1	5	7	0	6	0	6	32
Apprch %	50	50	0		11.8	88.2	0		14.3	14.3	71.4		0	100	0		
Total %	3.1	3.1	0	6.2	6.2	46.9	0	53.1	3.1	3.1	15.6	21.9	0	18.8	0	18.8	

Start Time	Valley View Avenue Southbound				Central Avenue Westbound				Lena Road Northbound				Central Avenue Eastbound				Int. Total
	Left	Thru	Right	App. Total	Left	Thru	Right	App. Total	Left	Thru	Right	App. Total	Left	Thru	Right	App. Total	
04:30 PM	0	0	0	0	0	5	0	5	0	0	0	0	0	0	0	0	5
04:45 PM	0	0	0	0	0	2	0	2	0	0	1	1	0	2	0	2	5
05:00 PM	0	0	0	0	1	2	0	3	0	0	0	0	0	0	0	0	3
05:15 PM	0	0	0	0	0	1	0	1	0	0	0	0	0	1	0	1	2
Total Volume	0	0	0	0	1	10	0	11	0	0	1	1	0	3	0	3	15
% App. Total	0	0	0		9.1	90.9	0		0	0	100		0	100	0		
PHF	.000	.000	.000	.000	.250	.500	.000	.550	.000	.000	.250	.250	.000	.375	.000	.375	.750

Peak Hour Analysis From 04:30 PM to 05:15 PM - Peak 1 of 1

Peak Hour for Entire Intersection Begins at 04:30 PM

City of San Bernardino
 N/S: Valley View Ave/Lena Road
 E/W: Central Avenue
 Weather: Clear

File Name : 01_SBC_Lena_Central PM
 Site Code : 99921278
 Start Date : 6/15/2021
 Page No : 2

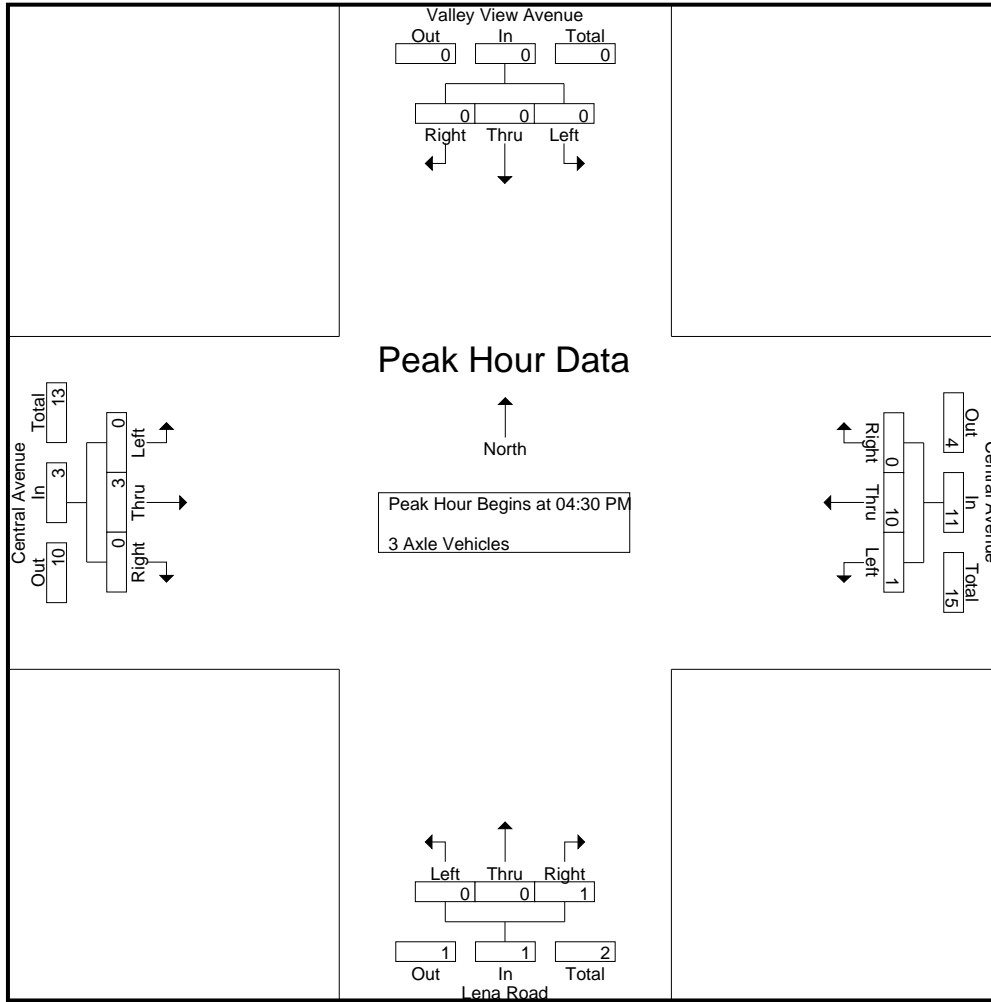

Peak Hour Analysis From 04:30 PM to 05:15 PM - Peak 1 of 1
 Peak Hour for Each Approach Begins at:

	04:30 PM				04:30 PM				04:30 PM				04:30 PM			
+0 mins.	0	0	0	0	0	5	0	5	0	0	0	0	0	0	0	0
+15 mins.	0	0	0	0	0	2	0	2	0	0	1	1	0	2	0	2
+30 mins.	0	0	0	0	1	2	0	3	0	0	0	0	0	0	0	0
+45 mins.	0	0	0	0	0	1	0	1	0	0	0	0	0	1	0	1
Total Volume	0	0	0	0	1	10	0	11	0	0	1	1	0	3	0	3
% App. Total	0	0	0	0	9.1	90.9	0	0	0	0	100	0	0	100	0	0
PHF	.000	.000	.000	.000	.250	.500	.000	.550	.000	.000	.250	.250	.000	.375	.000	.375

City of San Bernardino
 N/S: Valley View Ave/Lena Road
 E/W: Central Avenue
 Weather: Clear

File Name : 01_SBC_Lena_Central PM
 Site Code : 99921278
 Start Date : 6/15/2021
 Page No : 1

Groups Printed- 4+ Axle Trucks

Start Time	Valley View Avenue Southbound				Central Avenue Westbound				Lena Road Northbound				Central Avenue Eastbound				Int. Total
	Left	Thru	Right	App. Total	Left	Thru	Right	App. Total	Left	Thru	Right	App. Total	Left	Thru	Right	App. Total	
04:00 PM	0	0	0	0	0	3	0	3	1	0	3	4	0	0	0	0	7
04:15 PM	0	0	0	0	0	4	0	4	0	0	1	1	0	2	0	2	7
04:30 PM	0	0	0	0	0	0	0	0	0	0	1	1	0	0	0	0	1
04:45 PM	0	0	0	0	0	2	0	2	0	0	1	1	0	1	0	1	4
Total	0	0	0	0	0	9	0	9	1	0	6	7	0	3	0	3	19
05:00 PM	0	0	0	0	0	1	0	1	0	0	1	1	0	1	0	1	3
05:15 PM	0	0	0	0	0	1	0	1	0	0	0	0	0	1	0	1	2
05:30 PM	0	0	0	0	1	1	0	2	0	2	2	4	0	0	0	0	6
05:45 PM	0	0	0	0	0	1	0	1	0	0	0	0	0	1	0	1	2
Total	0	0	0	0	1	4	0	5	0	2	3	5	0	3	0	3	13
Grand Total	0	0	0	0	1	13	0	14	1	2	9	12	0	6	0	6	32
Apprch %	0	0	0		7.1	92.9	0		8.3	16.7	75		0	100	0		
Total %	0	0	0	0	3.1	40.6	0	43.8	3.1	6.2	28.1	37.5	0	18.8	0	18.8	

Start Time	Valley View Avenue Southbound				Central Avenue Westbound				Lena Road Northbound				Central Avenue Eastbound				Int. Total
	Left	Thru	Right	App. Total	Left	Thru	Right	App. Total	Left	Thru	Right	App. Total	Left	Thru	Right	App. Total	
04:30 PM	0	0	0	0	0	0	0	0	0	0	1	1	0	0	0	0	1
04:45 PM	0	0	0	0	0	2	0	2	0	0	1	1	0	1	0	1	4
05:00 PM	0	0	0	0	0	1	0	1	0	0	1	1	0	1	0	1	3
05:15 PM	0	0	0	0	0	1	0	1	0	0	0	0	0	1	0	1	2
Total Volume	0	0	0	0	0	4	0	4	0	0	3	3	0	3	0	3	10
% App. Total	0	0	0		0	100	0		0	0	100		0	100	0		
PHF	.000	.000	.000	.000	.000	.500	.000	.500	.000	.000	.750	.750	.000	.750	.000	.750	.625

Peak Hour Analysis From 04:30 PM to 05:15 PM - Peak 1 of 1
 Peak Hour for Entire Intersection Begins at 04:30 PM

City of San Bernardino
 N/S: Valley View Ave/Lena Road
 E/W: Central Avenue
 Weather: Clear

File Name : 01_SBC_Lena_Central PM
 Site Code : 99921278
 Start Date : 6/15/2021
 Page No : 2

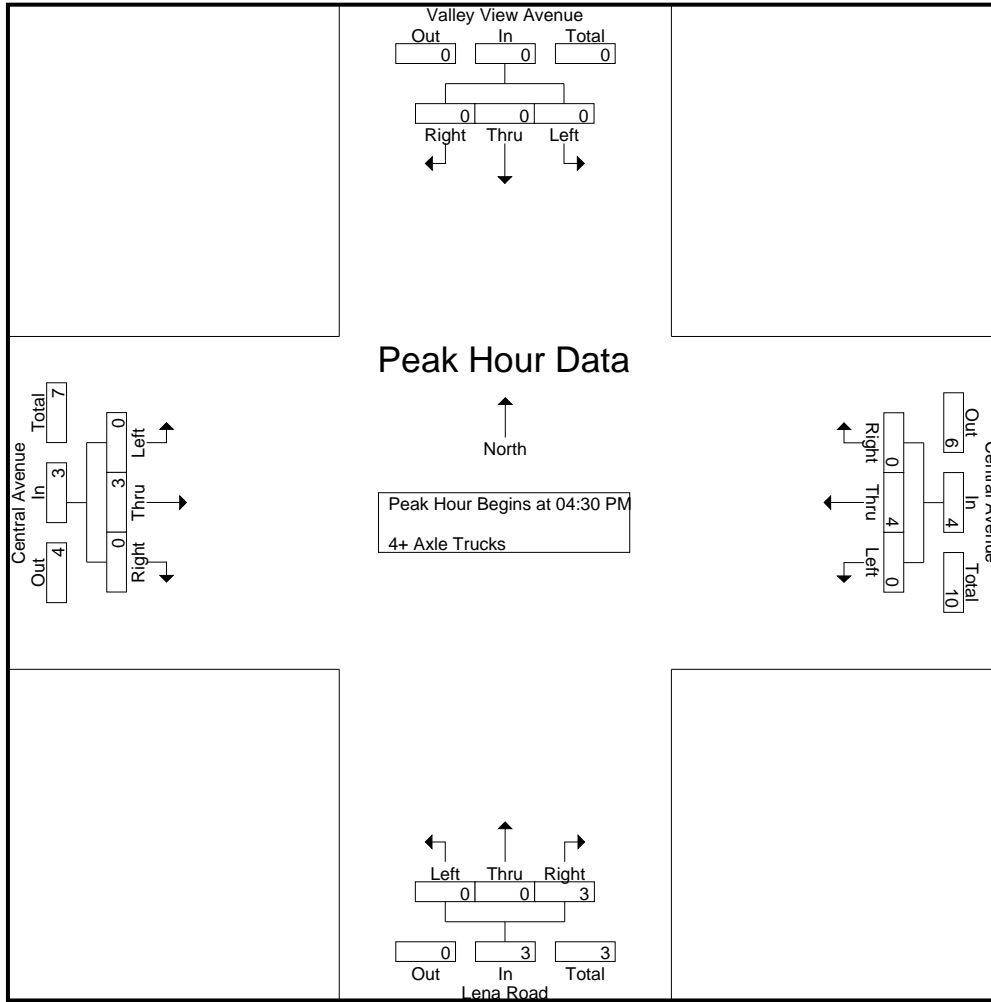

Peak Hour Analysis From 04:30 PM to 05:15 PM - Peak 1 of 1
 Peak Hour for Each Approach Begins at:

	04:30 PM				04:30 PM				04:30 PM				04:30 PM			
+0 mins.	0	0	0	0	0	0	0	0	0	0	1	1	0	0	0	0
+15 mins.	0	0	0	0	0	2	0	2	0	0	1	1	0	1	0	1
+30 mins.	0	0	0	0	0	1	0	1	0	0	1	1	0	1	0	1
+45 mins.	0	0	0	0	0	1	0	1	0	0	0	0	0	1	0	1
Total Volume	0	0	0	0	0	4	0	4	0	0	3	3	0	3	0	3
% App. Total	0	0	0	0	0	100	0	0	0	0	100	0	0	100	0	0
PHF	.000	.000	.000	.000	.000	.500	.000	.500	.000	.000	.750	.750	.000	.750	.000	.750

City of San Bernardino
 N/S: Lena Road
 E/W: Norman Road
 Weather: Clear

File Name : 02_SBC_Lena_Norman AM
 Site Code : 99921278
 Start Date : 6/15/2021
 Page No : 1

Groups Printed- Passenger Vehicles - Large 2 Axle Vehicles - 3 Axle Vehicles - 4+ Axle Trucks

Start Time	Lena Road Southbound				Norman Road Westbound				Lena Road Northbound				Norman Road Eastbound				Int. Total
	Left	Thru	Right	App. Total	Left	Thru	Right	App. Total	Left	Thru	Right	App. Total	Left	Thru	Right	App. Total	
07:00 AM	1	9	1	11	3	0	0	3	3	21	3	27	0	0	2	2	43
07:15 AM	0	5	0	5	1	1	1	3	0	19	3	22	0	0	0	0	30
07:30 AM	1	6	1	8	2	2	0	4	1	22	6	29	0	0	1	1	42
07:45 AM	0	8	0	8	3	1	1	5	1	35	6	42	1	0	0	1	56
Total	2	28	2	32	9	4	2	15	5	97	18	120	1	0	3	4	171
08:00 AM	1	8	1	10	3	0	2	5	1	20	7	28	1	2	1	4	47
08:15 AM	0	10	0	10	2	1	0	3	1	14	9	24	1	1	0	2	39
08:30 AM	1	12	0	13	6	0	0	6	2	17	4	23	0	1	0	1	43
08:45 AM	3	16	0	19	28	1	1	30	1	9	9	19	0	0	1	1	69
Total	5	46	1	52	39	2	3	44	5	60	29	94	2	4	2	8	198
Grand Total	7	74	3	84	48	6	5	59	10	157	47	214	3	4	5	12	369
Apprch %	8.3	88.1	3.6		81.4	10.2	8.5		4.7	73.4	22		25	33.3	41.7		
Total %	1.9	20.1	0.8	22.8	13	1.6	1.4	16	2.7	42.5	12.7	58	0.8	1.1	1.4	3.3	
Passenger Vehicles	7	68	3	78	45	6	3	54	8	135	45	188	3	3	5	11	331
% Passenger Vehicles	100	91.9	100	92.9	93.8	100	60	91.5	80	86	95.7	87.9	100	75	100	91.7	89.7
Large 2 Axle Vehicles	0	0	0	0	1	0	1	2	0	3	1	4	0	1	0	1	7
% Large 2 Axle Vehicles	0	0	0	0	2.1	0	20	3.4	0	1.9	2.1	1.9	0	25	0	8.3	1.9
3 Axle Vehicles	0	1	0	1	1	0	0	1	2	8	1	11	0	0	0	0	13
% 3 Axle Vehicles	0	1.4	0	1.2	2.1	0	0	1.7	20	5.1	2.1	5.1	0	0	0	0	3.5
4+ Axle Trucks	0	5	0	5	1	0	1	2	0	11	0	11	0	0	0	0	18
% 4+ Axle Trucks	0	6.8	0	6	2.1	0	20	3.4	0	7	0	5.1	0	0	0	0	4.9

Start Time	Lena Road Southbound				Norman Road Westbound				Lena Road Northbound				Norman Road Eastbound				Int. Total
	Left	Thru	Right	App. Total	Left	Thru	Right	App. Total	Left	Thru	Right	App. Total	Left	Thru	Right	App. Total	
Peak Hour Analysis From 07:00 AM to 08:45 AM - Peak 1 of 1																	
Peak Hour for Entire Intersection Begins at 08:00 AM																	
08:00 AM	1	8	1	10	3	0	2	5	1	20	7	28	1	2	1	4	47
08:15 AM	0	10	0	10	2	1	0	3	1	14	9	24	1	1	0	2	39
08:30 AM	1	12	0	13	6	0	0	6	2	17	4	23	0	1	0	1	43
08:45 AM	3	16	0	19	28	1	1	30	1	9	9	19	0	0	1	1	69
Total Volume	5	46	1	52	39	2	3	44	5	60	29	94	2	4	2	8	198
% App. Total	9.6	88.5	1.9		88.6	4.5	6.8		5.3	63.8	30.9		25	50	25		
PHF	.417	.719	.250	.684	.348	.500	.375	.367	.625	.750	.806	.839	.500	.500	.500	.500	.717

City of San Bernardino
 N/S: Lena Road
 E/W: Norman Road
 Weather: Clear

File Name : 02_SBC_Lena_Norman AM
 Site Code : 99921278
 Start Date : 6/15/2021
 Page No : 2

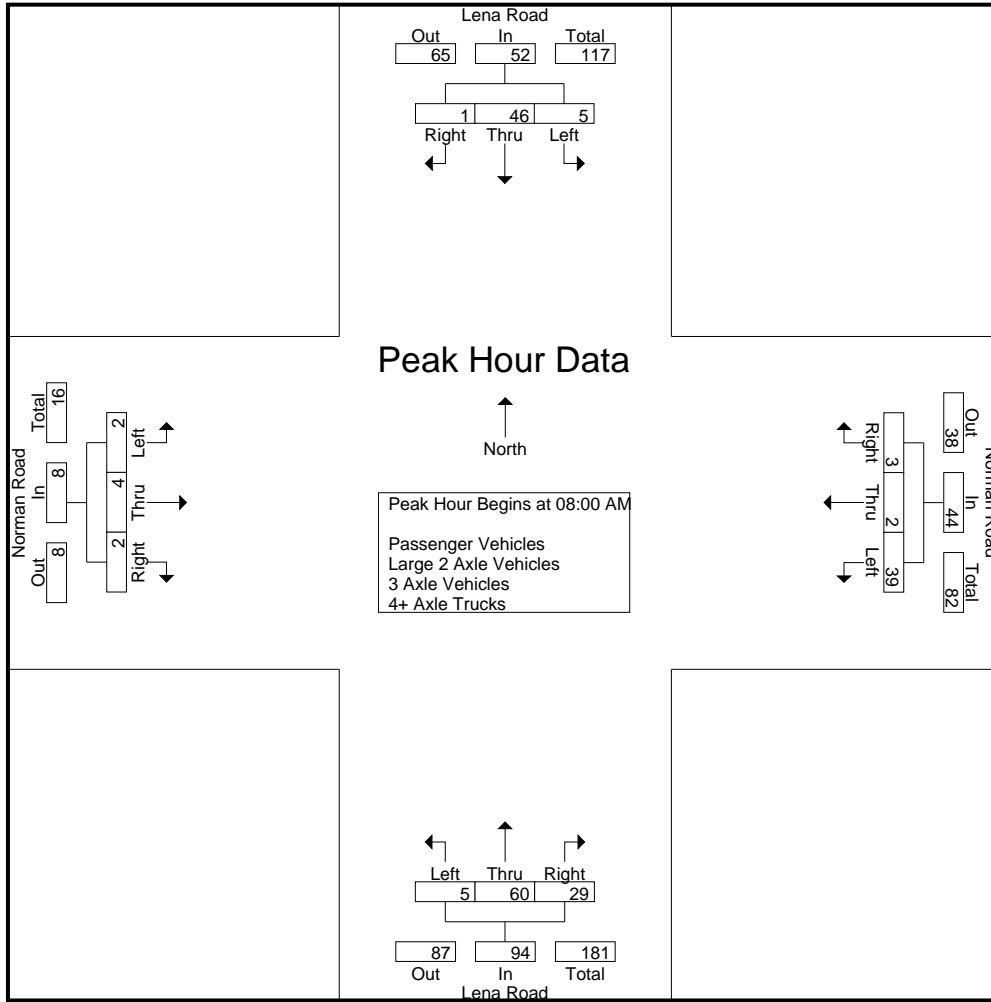

Peak Hour Analysis From 07:00 AM to 08:45 AM - Peak 1 of 1
 Peak Hour for Each Approach Begins at:

	08:00 AM				08:00 AM				07:30 AM				07:30 AM			
+0 mins.	1	8	1	10	3	0	2	5	1	22	6	29	0	0	1	1
+15 mins.	0	10	0	10	2	1	0	3	1	35	6	42	1	0	0	1
+30 mins.	1	12	0	13	6	0	0	6	1	20	7	28	1	2	1	4
+45 mins.	3	16	0	19	28	1	1	30	1	14	9	24	1	1	0	2
Total Volume	5	46	1	52	39	2	3	44	4	91	28	123	3	3	2	8
% App. Total	9.6	88.5	1.9		88.6	4.5	6.8		3.3	74	22.8		37.5	37.5	25	
PHF	.417	.719	.250	.684	.348	.500	.375	.367	1.000	.650	.778	.732	.750	.375	.500	.500

City of San Bernardino
 N/S: Lena Road
 E/W: Norman Road
 Weather: Clear

File Name : 02_SBC_Lena_Norman AM
 Site Code : 99921278
 Start Date : 6/15/2021
 Page No : 1

Groups Printed- Passenger Vehicles

Start Time	Lena Road Southbound				Norman Road Westbound				Lena Road Northbound				Norman Road Eastbound				Int. Total
	Left	Thru	Right	App. Total	Left	Thru	Right	App. Total	Left	Thru	Right	App. Total	Left	Thru	Right	App. Total	
07:00 AM	1	9	1	11	2	0	0	2	3	18	3	24	0	0	2	2	39
07:15 AM	0	5	0	5	1	1	1	3	0	18	2	20	0	0	0	0	28
07:30 AM	1	6	1	8	2	2	0	4	1	19	6	26	0	0	1	1	39
07:45 AM	0	8	0	8	3	1	1	5	1	31	6	38	1	0	0	1	52
Total	2	28	2	32	8	4	2	14	5	86	17	108	1	0	3	4	158
08:00 AM	1	7	1	9	3	0	1	4	1	17	7	25	1	1	1	3	41
08:15 AM	0	9	0	9	2	1	0	3	0	12	8	20	1	1	0	2	34
08:30 AM	1	12	0	13	5	0	0	5	1	12	4	17	0	1	0	1	36
08:45 AM	3	12	0	15	27	1	0	28	1	8	9	18	0	0	1	1	62
Total	5	40	1	46	37	2	1	40	3	49	28	80	2	3	2	7	173
Grand Total	7	68	3	78	45	6	3	54	8	135	45	188	3	3	5	11	331
Apprch %	9	87.2	3.8		83.3	11.1	5.6		4.3	71.8	23.9		27.3	27.3	45.5		
Total %	2.1	20.5	0.9	23.6	13.6	1.8	0.9	16.3	2.4	40.8	13.6	56.8	0.9	0.9	1.5	3.3	

Start Time	Lena Road Southbound				Norman Road Westbound				Lena Road Northbound				Norman Road Eastbound				Int. Total
	Left	Thru	Right	App. Total	Left	Thru	Right	App. Total	Left	Thru	Right	App. Total	Left	Thru	Right	App. Total	
08:00 AM	1	7	1	9	3	0	1	4	1	17	7	25	1	1	1	3	41
08:15 AM	0	9	0	9	2	1	0	3	0	12	8	20	1	1	0	2	34
08:30 AM	1	12	0	13	5	0	0	5	1	12	4	17	0	1	0	1	36
08:45 AM	3	12	0	15	27	1	0	28	1	8	9	18	0	0	1	1	62
Total Volume	5	40	1	46	37	2	1	40	3	49	28	80	2	3	2	7	173
% App. Total	10.9	87	2.2		92.5	5	2.5		3.8	61.2	35		28.6	42.9	28.6		
PHF	.417	.833	.250	.767	.343	.500	.250	.357	.750	.721	.778	.800	.500	.750	.500	.583	.698

Peak Hour Analysis From 08:00 AM to 08:45 AM - Peak 1 of 1
 Peak Hour for Entire Intersection Begins at 08:00 AM

City of San Bernardino
 N/S: Lena Road
 E/W: Norman Road
 Weather: Clear

File Name : 02_SBC_Lena_Norman AM
 Site Code : 99921278
 Start Date : 6/15/2021
 Page No : 2

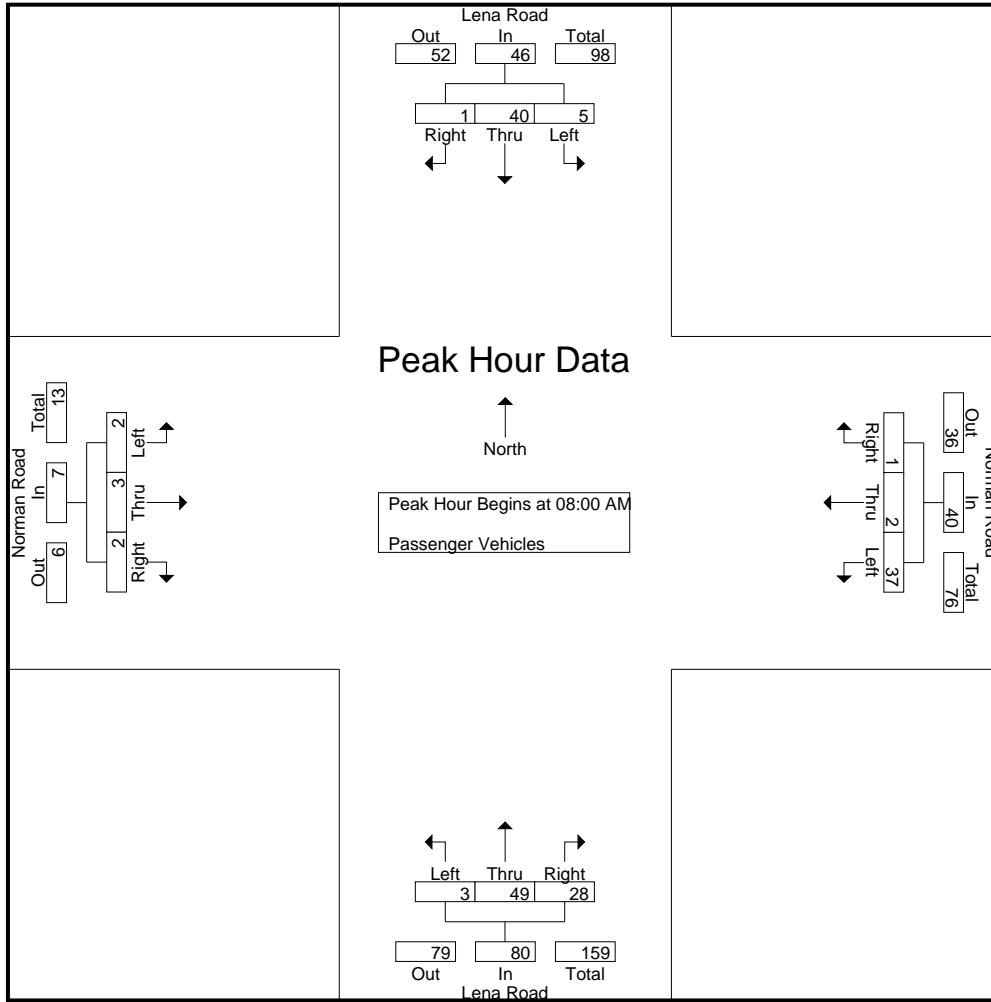

Peak Hour Analysis From 08:00 AM to 08:45 AM - Peak 1 of 1
 Peak Hour for Each Approach Begins at:

	08:00 AM				08:00 AM				08:00 AM				08:00 AM			
+0 mins.	1	7	1	9	3	0	1	4	1	17	7	25	1	1	1	3
+15 mins.	0	9	0	9	2	1	0	3	0	12	8	20	1	1	0	2
+30 mins.	1	12	0	13	5	0	0	5	1	12	4	17	0	1	0	1
+45 mins.	3	12	0	15	27	1	0	28	1	8	9	18	0	0	1	1
Total Volume	5	40	1	46	37	2	1	40	3	49	28	80	2	3	2	7
% App. Total	10.9	87	2.2		92.5	5	2.5		3.8	61.2	35		28.6	42.9	28.6	
PHF	.417	.833	.250	.767	.343	.500	.250	.357	.750	.721	.778	.800	.500	.750	.500	.583

City of San Bernardino
 N/S: Lena Road
 E/W: Norman Road
 Weather: Clear

File Name : 02_SBC_Lena_Norman AM
 Site Code : 99921278
 Start Date : 6/15/2021
 Page No : 1

Groups Printed- Large 2 Axle Vehicles

Start Time	Lena Road Southbound				Norman Road Westbound				Lena Road Northbound				Norman Road Eastbound				Int. Total
	Left	Thru	Right	App. Total	Left	Thru	Right	App. Total	Left	Thru	Right	App. Total	Left	Thru	Right	App. Total	
07:00 AM	0	0	0	0	0	0	0	0	0	1	0	1	0	0	0	0	1
07:15 AM	0	0	0	0	0	0	0	0	0	1	1	2	0	0	0	0	2
07:30 AM	0	0	0	0	0	0	0	0	0	1	0	1	0	0	0	0	1
07:45 AM	0	0	0	0	0	0	0	0	0	0	0	0	0	0	0	0	0
Total	0	0	0	0	0	0	0	0	0	3	1	4	0	0	0	0	4
08:00 AM	0	0	0	0	0	0	1	1	0	0	0	0	0	1	0	1	2
08:15 AM	0	0	0	0	0	0	0	0	0	0	0	0	0	0	0	0	0
08:30 AM	0	0	0	0	1	0	0	1	0	0	0	0	0	0	0	0	1
08:45 AM	0	0	0	0	0	0	0	0	0	0	0	0	0	0	0	0	0
Total	0	0	0	0	1	0	1	2	0	0	0	0	0	1	0	1	3
Grand Total	0	0	0	0	1	0	1	2	0	3	1	4	0	1	0	1	7
Apprch %	0	0	0		50	0	50		0	75	25		0	100	0		
Total %	0	0	0	0	14.3	0	14.3	28.6	0	42.9	14.3	57.1	0	14.3	0	14.3	

Start Time	Lena Road Southbound				Norman Road Westbound				Lena Road Northbound				Norman Road Eastbound				Int. Total
	Left	Thru	Right	App. Total	Left	Thru	Right	App. Total	Left	Thru	Right	App. Total	Left	Thru	Right	App. Total	
Peak Hour Analysis From 08:00 AM to 08:45 AM - Peak 1 of 1																	
Peak Hour for Entire Intersection Begins at 08:00 AM																	
08:00 AM	0	0	0	0	0	0	1	1	0	0	0	0	0	1	0	1	2
08:15 AM	0	0	0	0	0	0	0	0	0	0	0	0	0	0	0	0	0
08:30 AM	0	0	0	0	1	0	0	1	0	0	0	0	0	0	0	0	1
08:45 AM	0	0	0	0	0	0	0	0	0	0	0	0	0	0	0	0	0
Total Volume	0	0	0	0	1	0	1	2	0	0	0	0	0	1	0	1	3
% App. Total	0	0	0		50	0	50		0	0	0		0	100	0		
PHF	.000	.000	.000	.000	.250	.000	.250	.500	.000	.000	.000	.000	.000	.250	.000	.250	.375

City of San Bernardino
 N/S: Lena Road
 E/W: Norman Road
 Weather: Clear

File Name : 02_SBC_Lena_Norman AM
 Site Code : 99921278
 Start Date : 6/15/2021
 Page No : 2

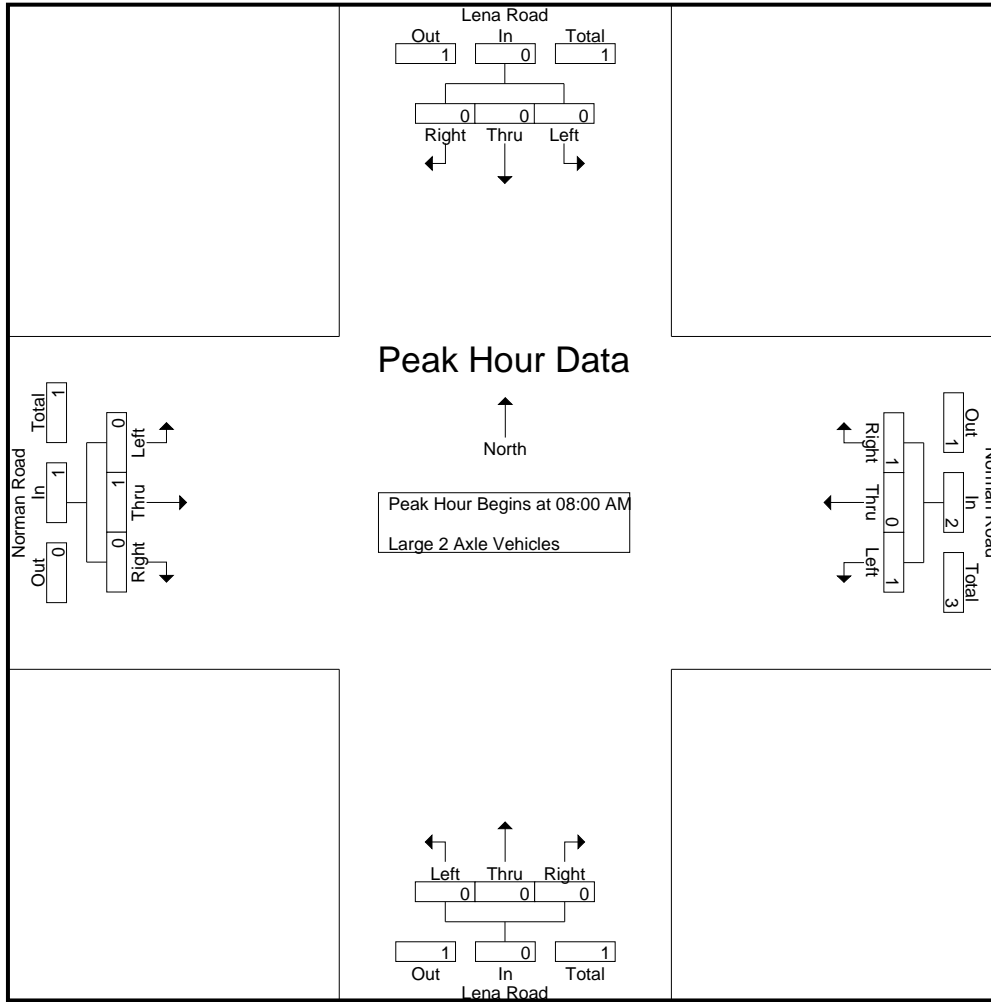

Peak Hour Analysis From 08:00 AM to 08:45 AM - Peak 1 of 1
 Peak Hour for Each Approach Begins at:

	08:00 AM				08:00 AM				08:00 AM				08:00 AM			
+0 mins.	0	0	0	0	0	0	1	1	0	0	0	0	0	1	0	1
+15 mins.	0	0	0	0	0	0	0	0	0	0	0	0	0	0	0	0
+30 mins.	0	0	0	0	1	0	0	1	0	0	0	0	0	0	0	0
+45 mins.	0	0	0	0	0	0	0	0	0	0	0	0	0	0	0	0
Total Volume	0	0	0	0	1	0	1	2	0	0	0	0	0	1	0	1
% App. Total	0	0	0	0	50	0	50	50	0	0	0	0	0	100	0	50
PHF	.000	.000	.000	.000	.250	.000	.250	.500	.000	.000	.000	.000	.000	.250	.000	.250

City of San Bernardino
 N/S: Lena Road
 E/W: Norman Road
 Weather: Clear

File Name : 02_SBC_Lena_Norman AM
 Site Code : 99921278
 Start Date : 6/15/2021
 Page No : 1

Groups Printed- 3 Axle Vehicles

Start Time	Lena Road Southbound				Norman Road Westbound				Lena Road Northbound				Norman Road Eastbound				Int. Total
	Left	Thru	Right	App. Total	Left	Thru	Right	App. Total	Left	Thru	Right	App. Total	Left	Thru	Right	App. Total	
07:00 AM	0	0	0	0	1	0	0	1	0	1	0	1	0	0	0	0	2
07:15 AM	0	0	0	0	0	0	0	0	0	0	0	0	0	0	0	0	0
07:30 AM	0	0	0	0	0	0	0	0	0	0	0	0	0	0	0	0	0
07:45 AM	0	0	0	0	0	0	0	0	0	1	0	1	0	0	0	0	1
Total	0	0	0	0	1	0	0	1	0	2	0	2	0	0	0	0	3
08:00 AM	0	0	0	0	0	0	0	0	0	2	0	2	0	0	0	0	2
08:15 AM	0	0	0	0	0	0	0	0	1	2	1	4	0	0	0	0	4
08:30 AM	0	0	0	0	0	0	0	0	1	2	0	3	0	0	0	0	3
08:45 AM	0	1	0	1	0	0	0	0	0	0	0	0	0	0	0	0	1
Total	0	1	0	1	0	0	0	0	2	6	1	9	0	0	0	0	10
Grand Total	0	1	0	1	1	0	0	1	2	8	1	11	0	0	0	0	13
Apprch %	0	100	0		100	0	0		18.2	72.7	9.1		0	0	0		
Total %	0	7.7	0	7.7	7.7	0	0	7.7	15.4	61.5	7.7	84.6	0	0	0	0	

Start Time	Lena Road Southbound				Norman Road Westbound				Lena Road Northbound				Norman Road Eastbound				Int. Total
	Left	Thru	Right	App. Total	Left	Thru	Right	App. Total	Left	Thru	Right	App. Total	Left	Thru	Right	App. Total	
08:00 AM	0	0	0	0	0	0	0	0	0	2	0	2	0	0	0	0	2
08:15 AM	0	0	0	0	0	0	0	0	1	2	1	4	0	0	0	0	4
08:30 AM	0	0	0	0	0	0	0	0	1	2	0	3	0	0	0	0	3
08:45 AM	0	1	0	1	0	0	0	0	0	0	0	0	0	0	0	0	1
Total Volume	0	1	0	1	0	0	0	0	2	6	1	9	0	0	0	0	10
% App. Total	0	100	0		0	0	0		22.2	66.7	11.1		0	0	0		
PHF	.000	.250	.000	.250	.000	.000	.000	.000	.500	.750	.250	.563	.000	.000	.000	.000	.625

Peak Hour Analysis From 08:00 AM to 08:45 AM - Peak 1 of 1

Peak Hour for Entire Intersection Begins at 08:00 AM

City of San Bernardino
 N/S: Lena Road
 E/W: Norman Road
 Weather: Clear

File Name : 02_SBC_Lena_Norman AM
 Site Code : 99921278
 Start Date : 6/15/2021
 Page No : 2

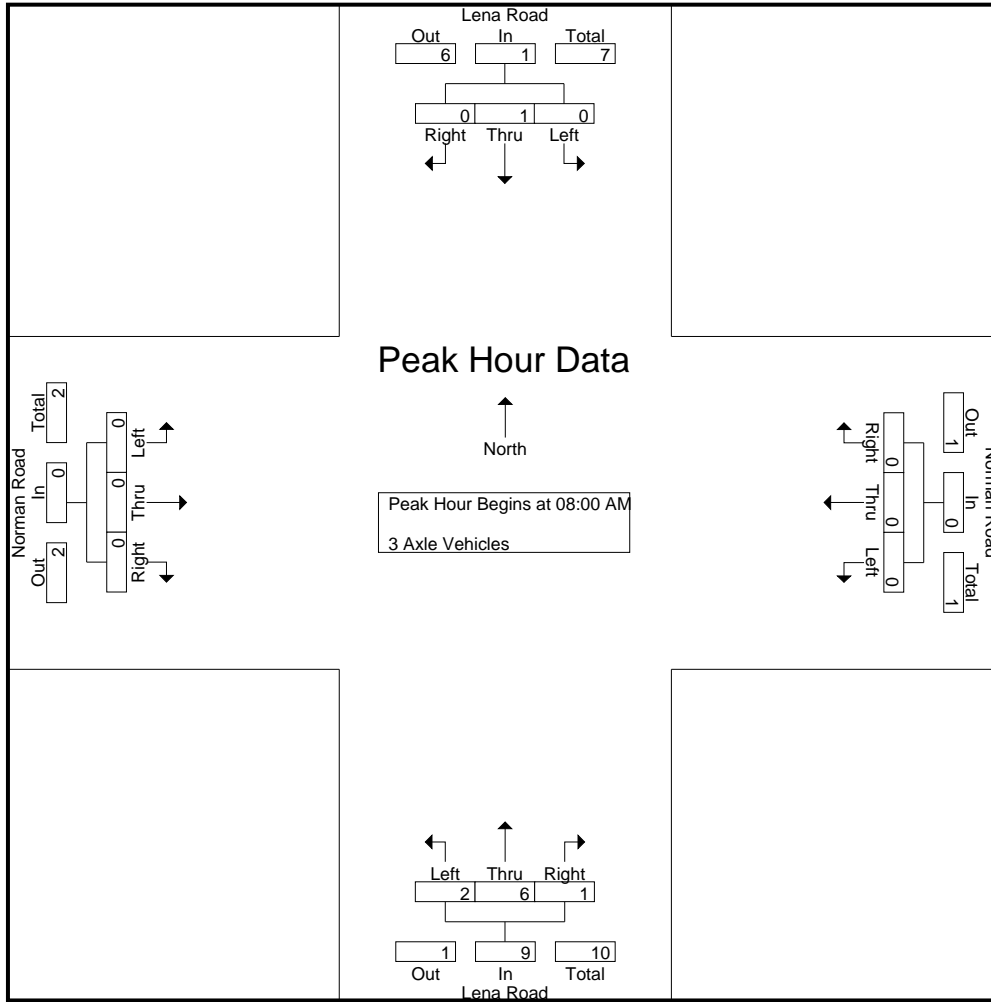

Peak Hour Analysis From 08:00 AM to 08:45 AM - Peak 1 of 1
 Peak Hour for Each Approach Begins at:

	08:00 AM				08:00 AM				08:00 AM				08:00 AM			
+0 mins.	0	0	0	0	0	0	0	0	0	2	0	2	0	0	0	0
+15 mins.	0	0	0	0	0	0	0	0	1	2	1	4	0	0	0	0
+30 mins.	0	0	0	0	0	0	0	0	1	2	0	3	0	0	0	0
+45 mins.	0	1	0	1	0	0	0	0	0	0	0	0	0	0	0	0
Total Volume	0	1	0	1	0	0	0	0	2	6	1	9	0	0	0	0
% App. Total	0	100	0	0	0	0	0	0	22.2	66.7	11.1		0	0	0	0
PHF	.000	.250	.000	.250	.000	.000	.000	.000	.500	.750	.250	.563	.000	.000	.000	.000

City of San Bernardino
 N/S: Lena Road
 E/W: Norman Road
 Weather: Clear

File Name : 02_SBC_Lena_Norman AM
 Site Code : 99921278
 Start Date : 6/15/2021
 Page No : 1

Groups Printed- 4+ Axle Trucks

Start Time	Lena Road Southbound				Norman Road Westbound				Lena Road Northbound				Norman Road Eastbound				Int. Total
	Left	Thru	Right	App. Total	Left	Thru	Right	App. Total	Left	Thru	Right	App. Total	Left	Thru	Right	App. Total	
07:00 AM	0	0	0	0	0	0	0	0	0	1	0	1	0	0	0	0	1
07:15 AM	0	0	0	0	0	0	0	0	0	0	0	0	0	0	0	0	0
07:30 AM	0	0	0	0	0	0	0	0	0	2	0	2	0	0	0	0	2
07:45 AM	0	0	0	0	0	0	0	0	0	3	0	3	0	0	0	0	3
Total	0	0	0	0	0	0	0	0	0	6	0	6	0	0	0	0	6
08:00 AM	0	1	0	1	0	0	0	0	0	1	0	1	0	0	0	0	2
08:15 AM	0	1	0	1	0	0	0	0	0	0	0	0	0	0	0	0	1
08:30 AM	0	0	0	0	0	0	0	0	0	3	0	3	0	0	0	0	3
08:45 AM	0	3	0	3	1	0	1	2	0	1	0	1	0	0	0	0	6
Total	0	5	0	5	1	0	1	2	0	5	0	5	0	0	0	0	12
Grand Total	0	5	0	5	1	0	1	2	0	11	0	11	0	0	0	0	18
Apprch %	0	100	0		50	0	50		0	100	0		0	0	0		
Total %	0	27.8	0	27.8	5.6	0	5.6	11.1	0	61.1	0	61.1	0	0	0	0	

Start Time	Lena Road Southbound				Norman Road Westbound				Lena Road Northbound				Norman Road Eastbound				Int. Total
	Left	Thru	Right	App. Total	Left	Thru	Right	App. Total	Left	Thru	Right	App. Total	Left	Thru	Right	App. Total	
08:00 AM	0	1	0	1	0	0	0	0	0	1	0	1	0	0	0	0	2
08:15 AM	0	1	0	1	0	0	0	0	0	0	0	0	0	0	0	0	1
08:30 AM	0	0	0	0	0	0	0	0	0	3	0	3	0	0	0	0	3
08:45 AM	0	3	0	3	1	0	1	2	0	1	0	1	0	0	0	0	6
Total Volume	0	5	0	5	1	0	1	2	0	5	0	5	0	0	0	0	12
% App. Total	0	100	0		50	0	50		0	100	0		0	0	0		
PHF	.000	.417	.000	.417	.250	.000	.250	.250	.000	.417	.000	.417	.000	.000	.000	.000	.500

Peak Hour Analysis From 08:00 AM to 08:45 AM - Peak 1 of 1

Peak Hour for Entire Intersection Begins at 08:00 AM

City of San Bernardino
 N/S: Lena Road
 E/W: Norman Road
 Weather: Clear

File Name : 02_SBC_Lena_Norman AM
 Site Code : 99921278
 Start Date : 6/15/2021
 Page No : 2

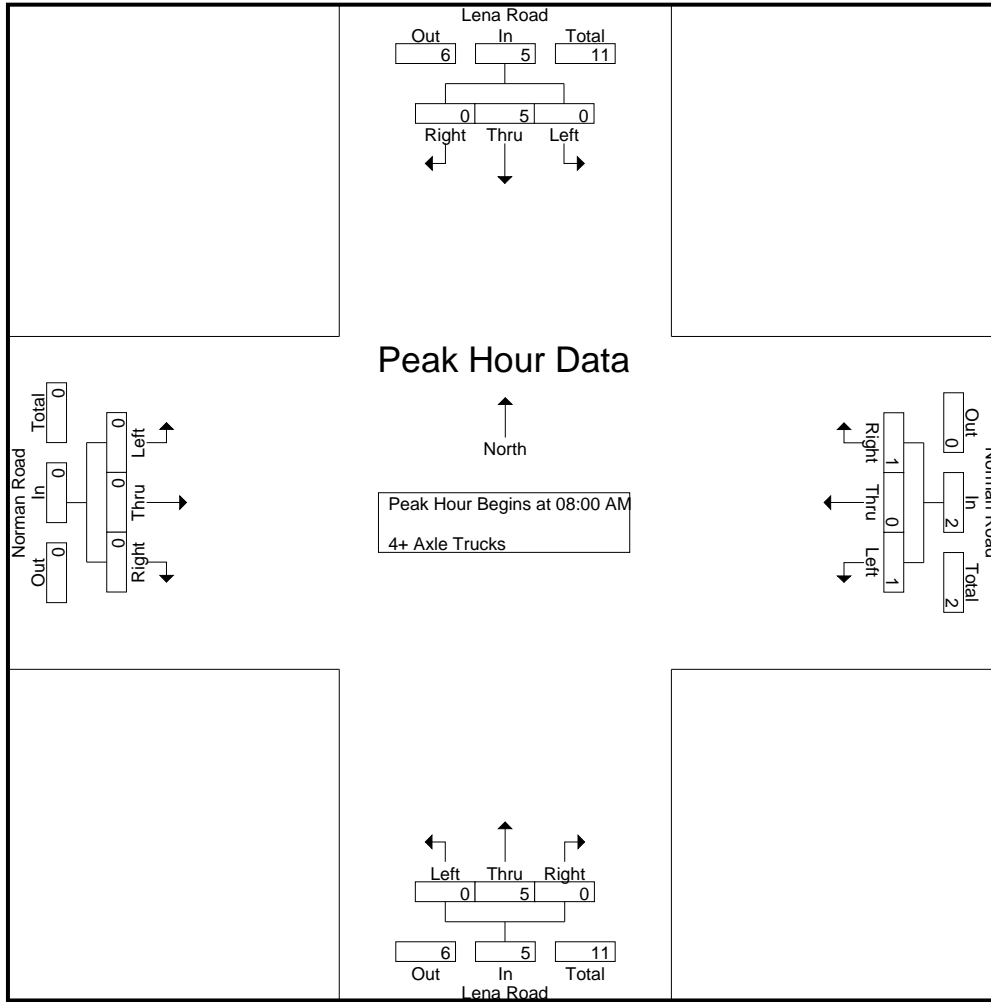

Peak Hour Analysis From 08:00 AM to 08:45 AM - Peak 1 of 1
 Peak Hour for Each Approach Begins at:

	08:00 AM				08:00 AM				08:00 AM				08:00 AM			
+0 mins.	0	1	0	1	0	0	0	0	0	1	0	1	0	0	0	0
+15 mins.	0	1	0	1	0	0	0	0	0	0	0	0	0	0	0	0
+30 mins.	0	0	0	0	0	0	0	0	0	3	0	3	0	0	0	0
+45 mins.	0	3	0	3	1	0	1	2	0	1	0	1	0	0	0	0
Total Volume	0	5	0	5	1	0	1	2	0	5	0	5	0	0	0	0
% App. Total	0	100	0	0	50	0	50	0	0	100	0	0	0	0	0	0
PHF	.000	.417	.000	.417	.250	.000	.250	.250	.000	.417	.000	.417	.000	.000	.000	.000

City of San Bernardino
 N/S: Lena Road
 E/W: Norman Road
 Weather: Clear

File Name : 02_SBC_Lena_Norman PM
 Site Code : 99921278
 Start Date : 6/15/2021
 Page No : 1

Groups Printed- Passenger Vehicles - Large 2 Axle Vehicles - 3 Axle Vehicles - 4+ Axle Trucks

Start Time	Lena Road Southbound				Norman Road Westbound				Lena Road Northbound				Norman Road Eastbound				Int. Total
	Left	Thru	Right	App. Total	Left	Thru	Right	App. Total	Left	Thru	Right	App. Total	Left	Thru	Right	App. Total	
04:00 PM	1	8	1	10	8	2	0	10	2	20	10	32	0	2	2	4	56
04:15 PM	1	10	1	12	4	1	0	5	1	12	13	26	0	1	1	2	45
04:30 PM	4	23	1	28	15	1	0	16	2	22	15	39	0	0	3	3	86
04:45 PM	1	4	2	7	12	4	2	18	3	23	16	42	0	0	0	0	67
Total	7	45	5	57	39	8	2	49	8	77	54	139	0	3	6	9	254
05:00 PM	1	20	1	22	2	1	1	4	1	19	6	26	1	4	1	6	58
05:15 PM	2	8	0	10	3	5	0	8	0	23	8	31	0	5	3	8	57
05:30 PM	1	14	0	15	4	3	2	9	1	18	5	24	0	2	1	3	51
05:45 PM	0	8	1	9	5	2	1	8	2	17	9	28	2	5	0	7	52
Total	4	50	2	56	14	11	4	29	4	77	28	109	3	16	5	24	218
Grand Total	11	95	7	113	53	19	6	78	12	154	82	248	3	19	11	33	472
Apprch %	9.7	84.1	6.2		67.9	24.4	7.7		4.8	62.1	33.1		9.1	57.6	33.3		
Total %	2.3	20.1	1.5	23.9	11.2	4	1.3	16.5	2.5	32.6	17.4	52.5	0.6	4	2.3	7	
Passenger Vehicles	11	89	7	107	52	16	6	74	12	130	76	218	2	14	10	26	425
% Passenger Vehicles	100	93.7	100	94.7	98.1	84.2	100	94.9	100	84.4	92.7	87.9	66.7	73.7	90.9	78.8	90
Large 2 Axle Vehicles	0	2	0	2	0	0	0	0	0	6	1	7	1	1	0	2	11
% Large 2 Axle Vehicles	0	2.1	0	1.8	0	0	0	0	0	3.9	1.2	2.8	33.3	5.3	0	6.1	2.3
3 Axle Vehicles	0	2	0	2	0	3	0	3	0	10	2	12	0	0	1	1	18
% 3 Axle Vehicles	0	2.1	0	1.8	0	15.8	0	3.8	0	6.5	2.4	4.8	0	0	9.1	3	3.8
4+ Axle Trucks	0	2	0	2	1	0	0	1	0	8	3	11	0	4	0	4	18
% 4+ Axle Trucks	0	2.1	0	1.8	1.9	0	0	1.3	0	5.2	3.7	4.4	0	21.1	0	12.1	3.8

Start Time	Lena Road Southbound				Norman Road Westbound				Lena Road Northbound				Norman Road Eastbound				Int. Total
	Left	Thru	Right	App. Total	Left	Thru	Right	App. Total	Left	Thru	Right	App. Total	Left	Thru	Right	App. Total	
Peak Hour Analysis From 04:00 PM to 05:45 PM - Peak 1 of 1																	
Peak Hour for Entire Intersection Begins at 04:30 PM																	
04:30 PM	4	23	1	28	15	1	0	16	2	22	15	39	0	0	3	3	86
04:45 PM	1	4	2	7	12	4	2	18	3	23	16	42	0	0	0	0	67
05:00 PM	1	20	1	22	2	1	1	4	1	19	6	26	1	4	1	6	58
05:15 PM	2	8	0	10	3	5	0	8	0	23	8	31	0	5	3	8	57
Total Volume	8	55	4	67	32	11	3	46	6	87	45	138	1	9	7	17	268
% App. Total	11.9	82.1	6		69.6	23.9	6.5		4.3	63	32.6		5.9	52.9	41.2		
PHF	.500	.598	.500	.598	.533	.550	.375	.639	.500	.946	.703	.821	.250	.450	.583	.531	.779

City of San Bernardino
 N/S: Lena Road
 E/W: Norman Road
 Weather: Clear

File Name : 02_SBC_Lena_Norman PM
 Site Code : 99921278
 Start Date : 6/15/2021
 Page No : 2

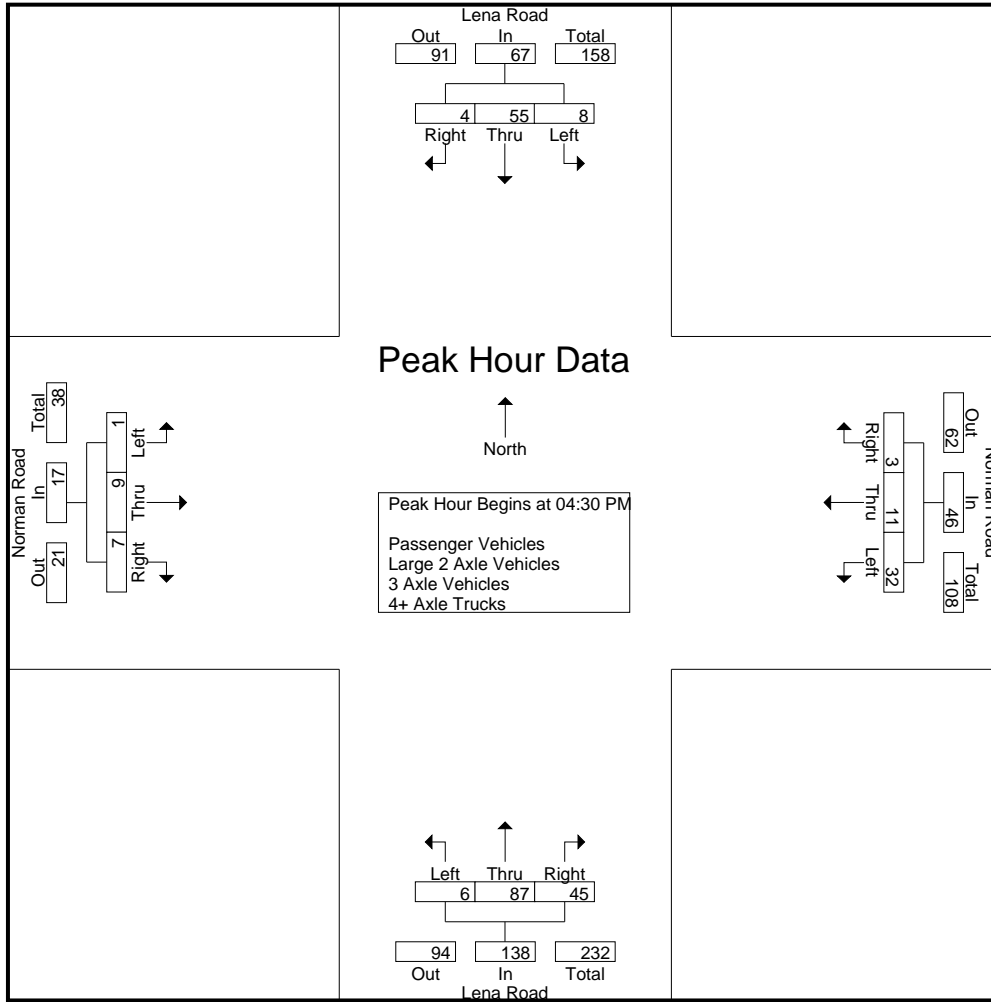

Peak Hour Analysis From 04:00 PM to 05:45 PM - Peak 1 of 1
 Peak Hour for Each Approach Begins at:

	04:15 PM				04:00 PM				04:00 PM				05:00 PM			
+0 mins.	1	10	1	12	8	2	0	10	2	20	10	32	1	4	1	6
+15 mins.	4	23	1	28	4	1	0	5	1	12	13	26	0	5	3	8
+30 mins.	1	4	2	7	15	1	0	16	2	22	15	39	0	2	1	3
+45 mins.	1	20	1	22	12	4	2	18	3	23	16	42	2	5	0	7
Total Volume	7	57	5	69	39	8	2	49	8	77	54	139	3	16	5	24
% App. Total	10.1	82.6	7.2		79.6	16.3	4.1		5.8	55.4	38.8		12.5	66.7	20.8	
PHF	.438	.620	.625	.616	.650	.500	.250	.681	.667	.837	.844	.827	.375	.800	.417	.750

City of San Bernardino
 N/S: Lena Road
 E/W: Norman Road
 Weather: Clear

File Name : 02_SBC_Lena_Norman PM
 Site Code : 99921278
 Start Date : 6/15/2021
 Page No : 1

Groups Printed- Passenger Vehicles

Start Time	Lena Road Southbound				Norman Road Westbound				Lena Road Northbound				Norman Road Eastbound				Int. Total
	Left	Thru	Right	App. Total	Left	Thru	Right	App. Total	Left	Thru	Right	App. Total	Left	Thru	Right	App. Total	
04:00 PM	1	7	1	9	8	1	0	9	2	15	10	27	0	2	2	4	49
04:15 PM	1	10	1	12	4	1	0	5	1	10	12	23	0	1	1	2	42
04:30 PM	4	22	1	27	15	1	0	16	2	20	14	36	0	0	3	3	82
04:45 PM	1	4	2	7	11	4	2	17	3	19	15	37	0	0	0	0	61
Total	7	43	5	55	38	7	2	47	8	64	51	123	0	3	6	9	234
05:00 PM	1	19	1	21	2	1	1	4	1	18	6	25	1	4	1	6	56
05:15 PM	2	8	0	10	3	4	0	7	0	21	7	28	0	3	3	6	51
05:30 PM	1	12	0	13	4	2	2	8	1	12	3	16	0	1	0	1	38
05:45 PM	0	7	1	8	5	2	1	8	2	15	9	26	1	3	0	4	46
Total	4	46	2	52	14	9	4	27	4	66	25	95	2	11	4	17	191
Grand Total	11	89	7	107	52	16	6	74	12	130	76	218	2	14	10	26	425
Apprch %	10.3	83.2	6.5		70.3	21.6	8.1		5.5	59.6	34.9		7.7	53.8	38.5		
Total %	2.6	20.9	1.6	25.2	12.2	3.8	1.4	17.4	2.8	30.6	17.9	51.3	0.5	3.3	2.4	6.1	

Start Time	Lena Road Southbound				Norman Road Westbound				Lena Road Northbound				Norman Road Eastbound				Int. Total
	Left	Thru	Right	App. Total	Left	Thru	Right	App. Total	Left	Thru	Right	App. Total	Left	Thru	Right	App. Total	
Peak Hour Analysis From 04:30 PM to 05:15 PM - Peak 1 of 1																	
Peak Hour for Entire Intersection Begins at 04:30 PM																	
04:30 PM	4	22	1	27	15	1	0	16	2	20	14	36	0	0	3	3	82
04:45 PM	1	4	2	7	11	4	2	17	3	19	15	37	0	0	0	0	61
05:00 PM	1	19	1	21	2	1	1	4	1	18	6	25	1	4	1	6	56
05:15 PM	2	8	0	10	3	4	0	7	0	21	7	28	0	3	3	6	51
Total Volume	8	53	4	65	31	10	3	44	6	78	42	126	1	7	7	15	250
% App. Total	12.3	81.5	6.2		70.5	22.7	6.8		4.8	61.9	33.3		6.7	46.7	46.7		
PHF	.500	.602	.500	.602	.517	.625	.375	.647	.500	.929	.700	.851	.250	.438	.583	.625	.762

City of San Bernardino
 N/S: Lena Road
 E/W: Norman Road
 Weather: Clear

File Name : 02_SBC_Lena_Norman PM
 Site Code : 99921278
 Start Date : 6/15/2021
 Page No : 2

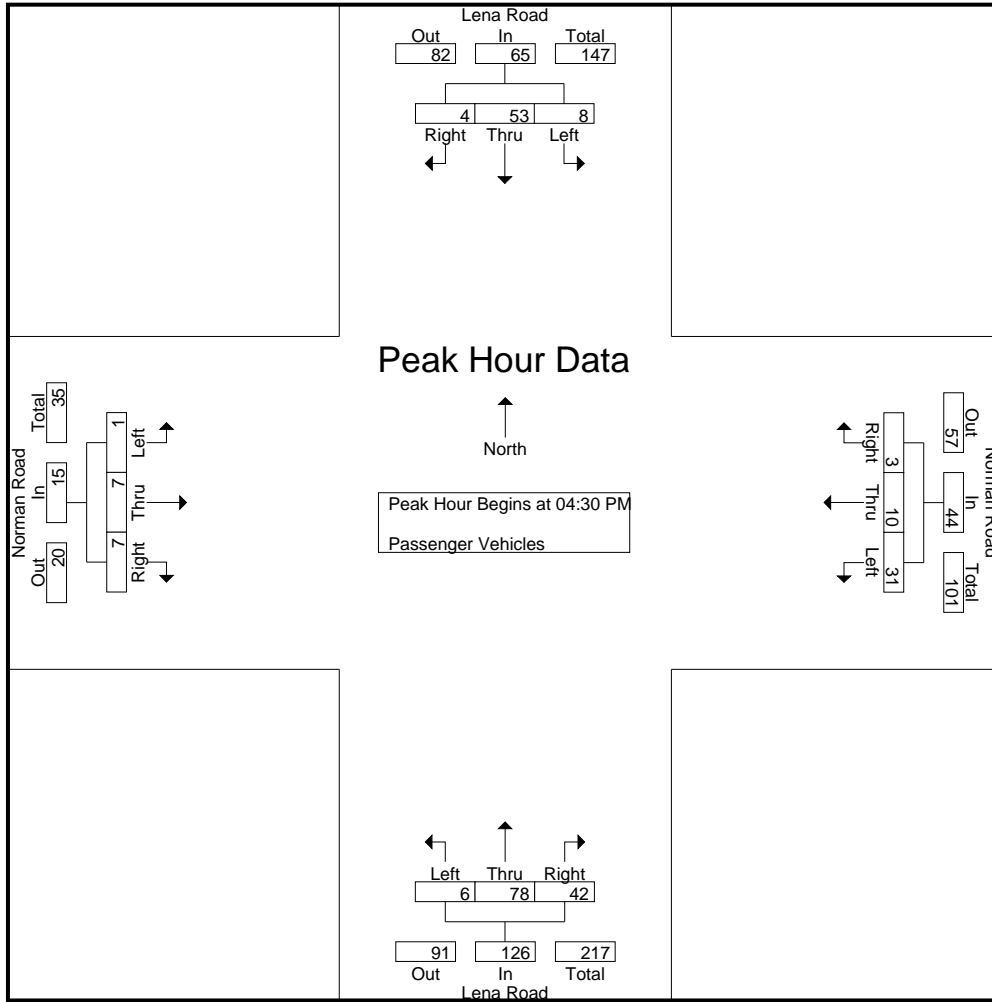

Peak Hour Analysis From 04:30 PM to 05:15 PM - Peak 1 of 1
 Peak Hour for Each Approach Begins at:

	04:30 PM				04:30 PM				04:30 PM				04:30 PM			
+0 mins.	4	22	1	27	15	1	0	16	2	20	14	36	0	0	0	3
+15 mins.	1	4	2	7	11	4	2	17	3	19	15	37	0	0	0	0
+30 mins.	1	19	1	21	2	1	1	4	1	18	6	25	1	4	1	6
+45 mins.	2	8	0	10	3	4	0	7	0	21	7	28	0	3	3	6
Total Volume	8	53	4	65	31	10	3	44	6	78	42	126	1	7	7	15
% App. Total	12.3	81.5	6.2		70.5	22.7	6.8		4.8	61.9	33.3		6.7	46.7	46.7	
PHF	.500	.602	.500	.602	.517	.625	.375	.647	.500	.929	.700	.851	.250	.438	.583	.625

City of San Bernardino
 N/S: Lena Road
 E/W: Norman Road
 Weather: Clear

File Name : 02_SBC_Lena_Norman PM
 Site Code : 99921278
 Start Date : 6/15/2021
 Page No : 1

Groups Printed- Large 2 Axle Vehicles

Start Time	Lena Road Southbound				Norman Road Westbound				Lena Road Northbound				Norman Road Eastbound				Int. Total	
	Left	Thru	Right	App. Total	Left	Thru	Right	App. Total	Left	Thru	Right	App. Total	Left	Thru	Right	App. Total		
04:00 PM	0	1	0	1	0	0	0	0	0	0	0	0	0	0	0	0	0	1
04:15 PM	0	0	0	0	0	0	0	0	0	0	0	0	0	0	0	0	0	0
04:30 PM	0	1	0	1	0	0	0	0	0	0	0	0	0	0	0	0	0	1
04:45 PM	0	0	0	0	0	0	0	0	0	0	2	1	3	0	0	0	0	3
Total	0	2	0	2	0	0	0	0	0	0	2	1	3	0	0	0	0	5
05:00 PM	0	0	0	0	0	0	0	0	0	0	0	0	0	0	0	0	0	0
05:15 PM	0	0	0	0	0	0	0	0	0	0	2	0	2	0	1	0	1	3
05:30 PM	0	0	0	0	0	0	0	0	0	0	1	0	1	0	0	0	0	1
05:45 PM	0	0	0	0	0	0	0	0	0	0	1	0	1	1	0	0	1	2
Total	0	0	0	0	0	0	0	0	0	0	4	0	4	1	1	0	2	6
Grand Total	0	2	0	2	0	0	0	0	0	0	6	1	7	1	1	0	2	11
Apprch %	0	100	0		0	0	0		0	85.7	14.3			50	50	0		
Total %	0	18.2	0	18.2	0	0	0	0	0	0	54.5	9.1	63.6	9.1	9.1	0	18.2	

Start Time	Lena Road Southbound				Norman Road Westbound				Lena Road Northbound				Norman Road Eastbound				Int. Total	
	Left	Thru	Right	App. Total	Left	Thru	Right	App. Total	Left	Thru	Right	App. Total	Left	Thru	Right	App. Total		
04:30 PM	0	1	0	1	0	0	0	0	0	0	0	0	0	0	0	0	0	1
04:45 PM	0	0	0	0	0	0	0	0	0	0	2	1	3	0	0	0	0	3
05:00 PM	0	0	0	0	0	0	0	0	0	0	0	0	0	0	0	0	0	0
05:15 PM	0	0	0	0	0	0	0	0	0	0	2	0	2	0	1	0	1	3
Total Volume	0	1	0	1	0	0	0	0	0	0	4	1	5	0	1	0	1	7
% App. Total	0	100	0		0	0	0		0	80	20			0	100	0		
PHF	.000	.250	.000	.250	.000	.000	.000	.000	.000	.000	.500	.250	.417	.000	.250	.000	.250	.583

Peak Hour Analysis From 04:30 PM to 05:15 PM - Peak 1 of 1

Peak Hour for Entire Intersection Begins at 04:30 PM

City of San Bernardino
 N/S: Lena Road
 E/W: Norman Road
 Weather: Clear

File Name : 02_SBC_Lena_Norman PM
 Site Code : 99921278
 Start Date : 6/15/2021
 Page No : 2

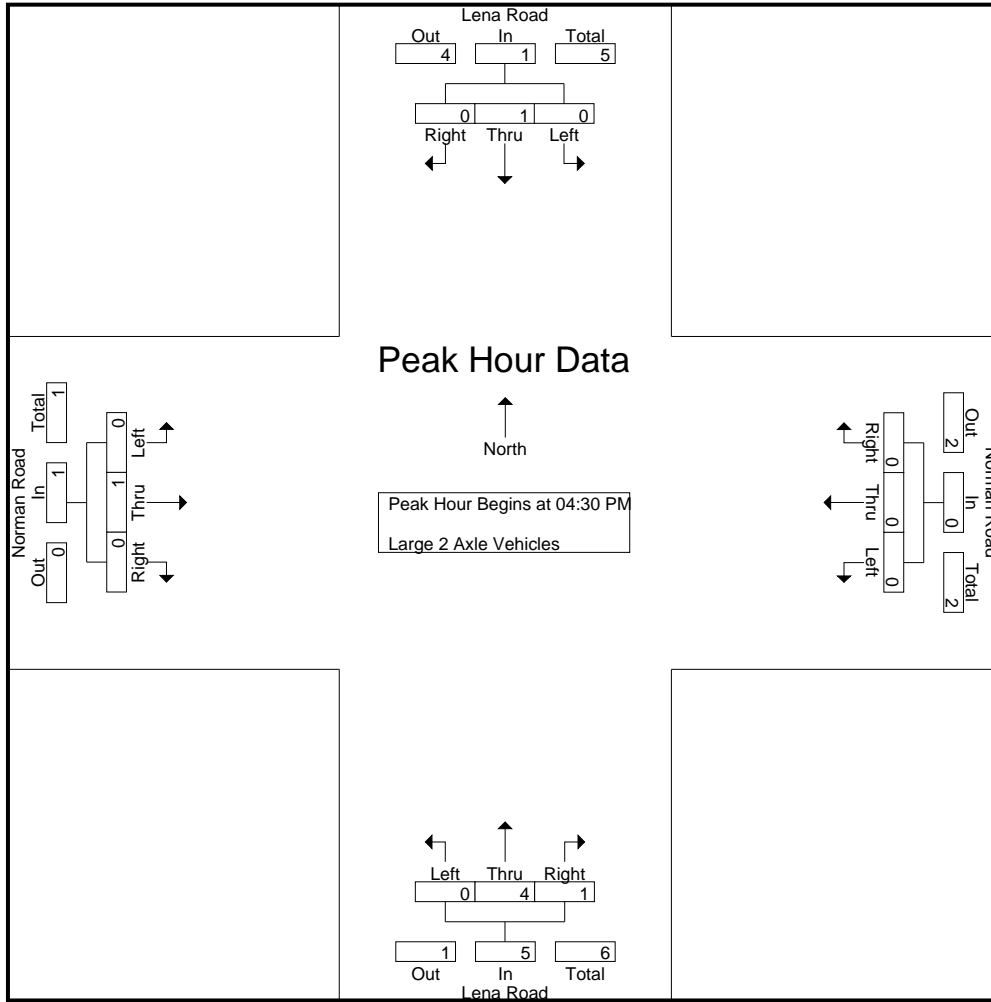

Peak Hour Analysis From 04:30 PM to 05:15 PM - Peak 1 of 1
 Peak Hour for Each Approach Begins at:

	04:30 PM				04:30 PM				04:30 PM				04:30 PM			
+0 mins.	0	1	0	1	0	0	0	0	0	0	0	0	0	0	0	0
+15 mins.	0	0	0	0	0	0	0	0	0	2	1	3	0	0	0	0
+30 mins.	0	0	0	0	0	0	0	0	0	0	0	0	0	0	0	0
+45 mins.	0	0	0	0	0	0	0	0	0	2	0	2	0	1	0	1
Total Volume	0	1	0	1	0	0	0	0	0	4	1	5	0	1	0	1
% App. Total	0	100	0	0	0	0	0	0	0	80	20	0	0	100	0	0
PHF	.000	.250	.000	.250	.000	.000	.000	.000	.000	.500	.250	.417	.000	.250	.000	.250

City of San Bernardino
 N/S: Lena Road
 E/W: Norman Road
 Weather: Clear

File Name : 02_SBC_Lena_Norman PM
 Site Code : 99921278
 Start Date : 6/15/2021
 Page No : 1

Groups Printed- 3 Axle Vehicles

Start Time	Lena Road Southbound				Norman Road Westbound				Lena Road Northbound				Norman Road Eastbound				Int. Total
	Left	Thru	Right	App. Total	Left	Thru	Right	App. Total	Left	Thru	Right	App. Total	Left	Thru	Right	App. Total	
04:00 PM	0	0	0	0	0	1	0	1	0	2	0	2	0	0	0	0	3
04:15 PM	0	0	0	0	0	0	0	0	0	2	1	3	0	0	0	0	3
04:30 PM	0	0	0	0	0	0	0	0	0	2	0	2	0	0	0	0	2
04:45 PM	0	0	0	0	0	0	0	0	0	1	0	1	0	0	0	0	1
Total	0	0	0	0	0	1	0	1	0	7	1	8	0	0	0	0	9
05:00 PM	0	0	0	0	0	0	0	0	0	0	0	0	0	0	0	0	0
05:15 PM	0	0	0	0	0	1	0	1	0	0	0	0	0	0	0	0	1
05:30 PM	0	1	0	1	0	1	0	1	0	2	1	3	0	0	1	1	6
05:45 PM	0	1	0	1	0	0	0	0	0	1	0	1	0	0	0	0	2
Total	0	2	0	2	0	2	0	2	0	3	1	4	0	0	1	1	9
Grand Total	0	2	0	2	0	3	0	3	0	10	2	12	0	0	1	1	18
Apprch %	0	100	0		0	100	0		0	83.3	16.7		0	0	100		
Total %	0	11.1	0	11.1	0	16.7	0	16.7	0	55.6	11.1	66.7	0	0	5.6	5.6	

Start Time	Lena Road Southbound				Norman Road Westbound				Lena Road Northbound				Norman Road Eastbound				Int. Total
	Left	Thru	Right	App. Total	Left	Thru	Right	App. Total	Left	Thru	Right	App. Total	Left	Thru	Right	App. Total	
04:30 PM	0	0	0	0	0	0	0	0	0	2	0	2	0	0	0	0	2
04:45 PM	0	0	0	0	0	0	0	0	0	1	0	1	0	0	0	0	1
05:00 PM	0	0	0	0	0	0	0	0	0	0	0	0	0	0	0	0	0
05:15 PM	0	0	0	0	0	1	0	1	0	0	0	0	0	0	0	0	1
Total Volume	0	0	0	0	0	1	0	1	0	3	0	3	0	0	0	0	4
% App. Total	0	0	0		0	100	0		0	100	0		0	0	0		
PHF	.000	.000	.000	.000	.000	.250	.000	.250	.000	.375	.000	.375	.000	.000	.000	.000	.500

Peak Hour Analysis From 04:30 PM to 05:15 PM - Peak 1 of 1

Peak Hour for Entire Intersection Begins at 04:30 PM

City of San Bernardino
 N/S: Lena Road
 E/W: Norman Road
 Weather: Clear

File Name : 02_SBC_Lena_Norman PM
 Site Code : 99921278
 Start Date : 6/15/2021
 Page No : 2

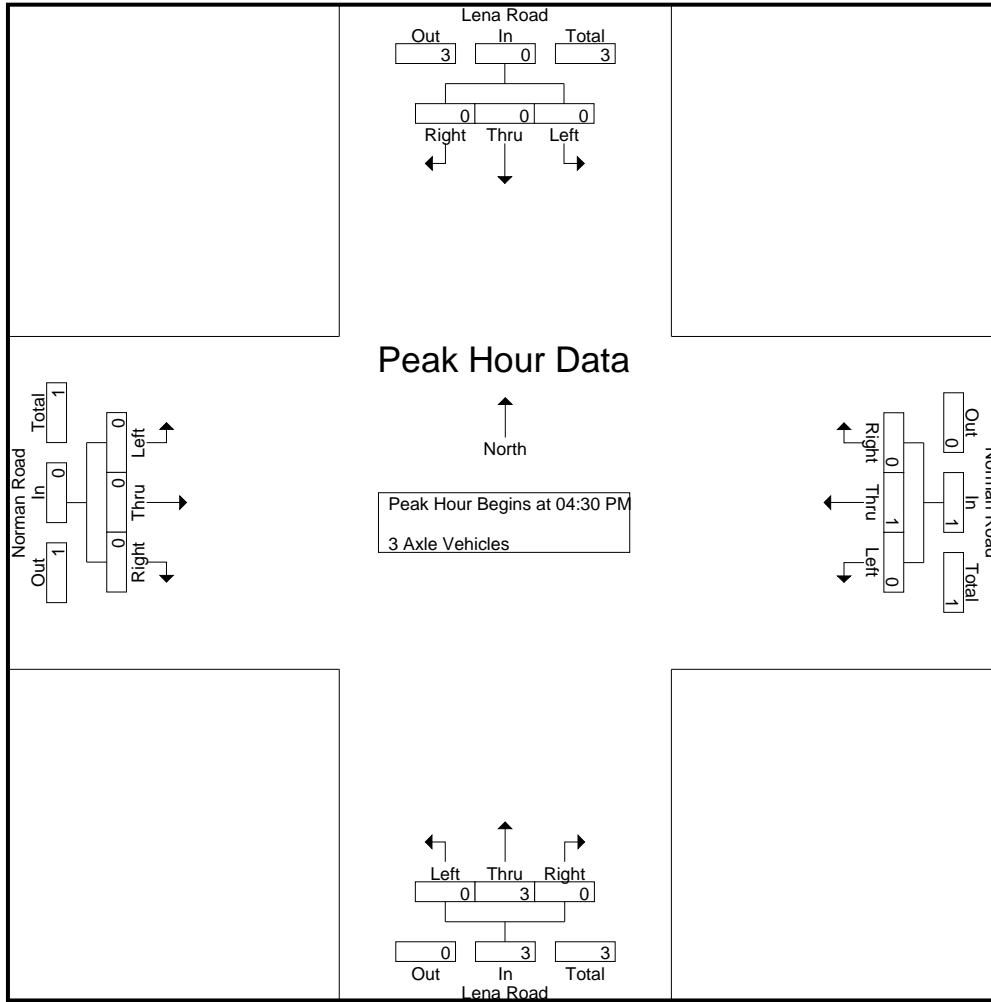

Peak Hour Analysis From 04:30 PM to 05:15 PM - Peak 1 of 1
 Peak Hour for Each Approach Begins at:

	04:30 PM				04:30 PM				04:30 PM				04:30 PM			
+0 mins.	0	0	0	0	0	0	0	0	0	2	0	2	0	0	0	0
+15 mins.	0	0	0	0	0	0	0	0	0	1	0	1	0	0	0	0
+30 mins.	0	0	0	0	0	0	0	0	0	0	0	0	0	0	0	0
+45 mins.	0	0	0	0	0	1	0	1	0	0	0	0	0	0	0	0
Total Volume	0	0	0	0	0	1	0	1	0	3	0	3	0	0	0	0
% App. Total	0	0	0	0	0	100	0	0	0	100	0	0	0	0	0	0
PHF	.000	.000	.000	.000	.000	.250	.000	.250	.000	.375	.000	.375	.000	.000	.000	.000

City of San Bernardino
 N/S: Lena Road
 E/W: Norman Road
 Weather: Clear

File Name : 02_SBC_Lena_Norman PM
 Site Code : 99921278
 Start Date : 6/15/2021
 Page No : 1

Groups Printed- 4+ Axle Trucks

Start Time	Lena Road Southbound				Norman Road Westbound				Lena Road Northbound				Norman Road Eastbound				Int. Total
	Left	Thru	Right	App. Total	Left	Thru	Right	App. Total	Left	Thru	Right	App. Total	Left	Thru	Right	App. Total	
04:00 PM	0	0	0	0	0	0	0	0	0	3	0	3	0	0	0	0	3
04:15 PM	0	0	0	0	0	0	0	0	0	0	0	0	0	0	0	0	0
04:30 PM	0	0	0	0	0	0	0	0	0	0	1	1	0	0	0	0	1
04:45 PM	0	0	0	0	1	0	0	1	0	1	0	1	0	0	0	0	2
Total	0	0	0	0	1	0	0	1	0	4	1	5	0	0	0	0	6
05:00 PM	0	1	0	1	0	0	0	0	0	1	0	1	0	0	0	0	2
05:15 PM	0	0	0	0	0	0	0	0	0	0	1	1	0	1	0	1	2
05:30 PM	0	1	0	1	0	0	0	0	0	3	1	4	0	1	0	1	6
05:45 PM	0	0	0	0	0	0	0	0	0	0	0	0	0	2	0	2	2
Total	0	2	0	2	0	0	0	0	0	4	2	6	0	4	0	4	12
Grand Total	0	2	0	2	1	0	0	1	0	8	3	11	0	4	0	4	18
Apprch %	0	100	0		100	0	0		0	72.7	27.3		0	100	0		
Total %	0	11.1	0	11.1	5.6	0	0	5.6	0	44.4	16.7	61.1	0	22.2	0	22.2	

Start Time	Lena Road Southbound				Norman Road Westbound				Lena Road Northbound				Norman Road Eastbound				Int. Total
	Left	Thru	Right	App. Total	Left	Thru	Right	App. Total	Left	Thru	Right	App. Total	Left	Thru	Right	App. Total	
04:30 PM	0	0	0	0	0	0	0	0	0	0	1	1	0	0	0	0	1
04:45 PM	0	0	0	0	1	0	0	1	0	1	0	1	0	0	0	0	2
05:00 PM	0	1	0	1	0	0	0	0	0	1	0	1	0	0	0	0	2
05:15 PM	0	0	0	0	0	0	0	0	0	0	1	1	0	1	0	1	2
Total Volume	0	1	0	1	1	0	0	1	0	2	2	4	0	1	0	1	7
% App. Total	0	100	0		100	0	0		0	50	50		0	100	0		
PHF	.000	.250	.000	.250	.250	.000	.000	.250	.000	.500	.500	1.00	.000	.250	.000	.250	.875

Peak Hour Analysis From 04:30 PM to 05:15 PM - Peak 1 of 1

Peak Hour for Entire Intersection Begins at 04:30 PM

City of San Bernardino
 N/S: Lena Road
 E/W: Norman Road
 Weather: Clear

File Name : 02_SBC_Lena_Norman PM
 Site Code : 99921278
 Start Date : 6/15/2021
 Page No : 2

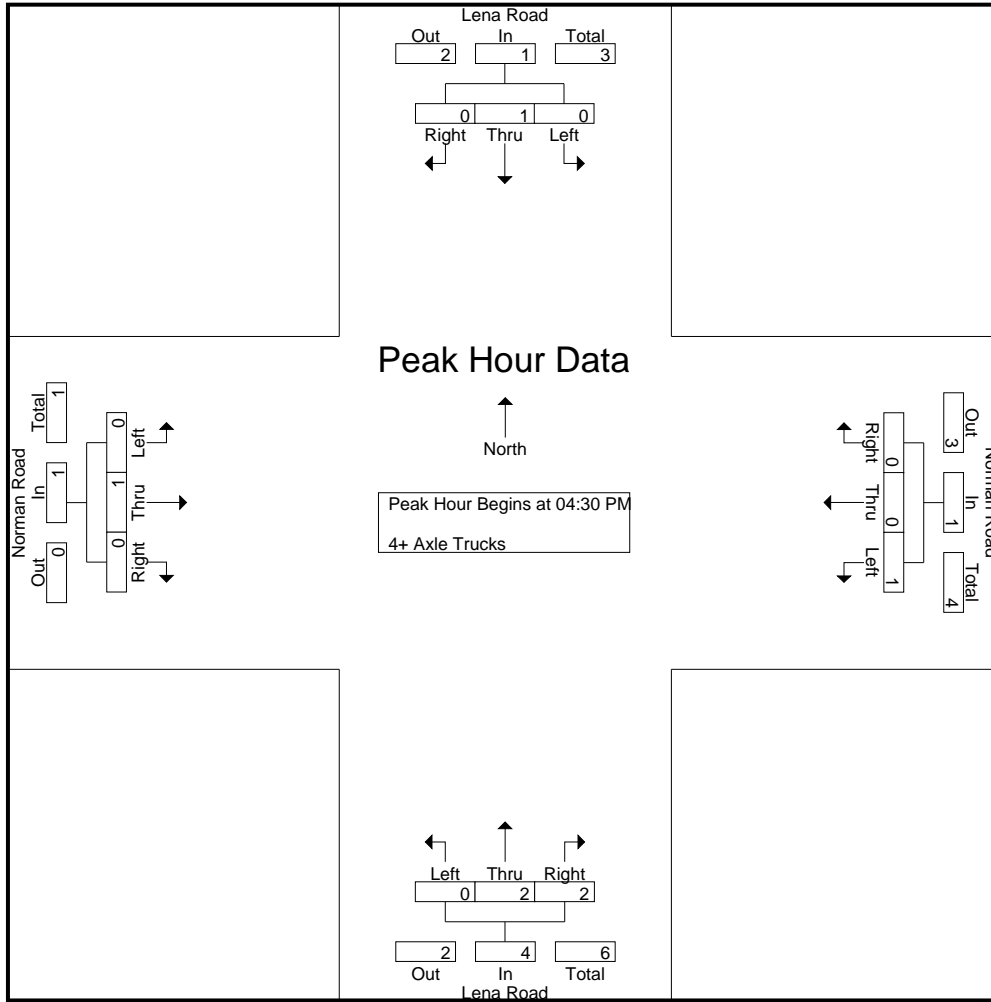

Peak Hour Analysis From 04:30 PM to 05:15 PM - Peak 1 of 1
 Peak Hour for Each Approach Begins at:

	04:30 PM				04:30 PM				04:30 PM				04:30 PM			
+0 mins.	0	0	0	0	0	0	0	0	0	0	1	1	0	0	0	0
+15 mins.	0	0	0	0	1	0	0	1	0	1	0	1	0	0	0	0
+30 mins.	0	1	0	1	0	0	0	0	0	1	0	1	0	0	0	0
+45 mins.	0	0	0	0	0	0	0	0	0	0	1	1	0	1	0	1
Total Volume	0	1	0	1	1	0	0	1	0	2	2	4	0	1	0	1
% App. Total	0	100	0		100	0	0		0	50	50		0	100	0	
PHF	.000	.250	.000	.250	.250	.000	.000	.250	.000	.500	.500	1.000	.000	.250	.000	.250

City of San Bernardino
 N/S: Lena Road
 E/W: Orange Show Road
 Weather: Clear

File Name : 03_SBC_Lena_Orange AM
 Site Code : 99921278
 Start Date : 6/15/2021
 Page No : 1

Groups Printed- Passenger Vehicles - Large 2 Axle Vehicles - 3 Axle Vehicles - 4+ Axle Trucks

Start Time	Lena Road Southbound			Orange Show Road Westbound			Orange Show Road Eastbound			Int. Total
	Left	Right	App. Total	Thru	Right	App. Total	Left	Thru	App. Total	
07:00 AM	2	10	12	46	8	54	18	81	99	165
07:15 AM	1	5	6	56	2	58	22	78	100	164
07:30 AM	1	8	9	85	4	89	25	64	89	187
07:45 AM	2	11	13	68	9	77	35	95	130	220
Total	6	34	40	255	23	278	100	318	418	736
08:00 AM	4	9	13	64	1	65	26	91	117	195
08:15 AM	1	12	13	62	4	66	20	65	85	164
08:30 AM	6	12	18	52	5	57	18	60	78	153
08:45 AM	5	40	45	69	5	74	14	66	80	199
Total	16	73	89	247	15	262	78	282	360	711
Grand Total	22	107	129	502	38	540	178	600	778	1447
Apprch %	17.1	82.9		93	7		22.9	77.1		
Total %	1.5	7.4	8.9	34.7	2.6	37.3	12.3	41.5	53.8	
Passenger Vehicles	20	98	118	405	31	436	158	529	687	1241
% Passenger Vehicles	90.9	91.6	91.5	80.7	81.6	80.7	88.8	88.2	88.3	85.8
Large 2 Axle Vehicles	0	2	2	22	3	25	4	14	18	45
% Large 2 Axle Vehicles	0	1.9	1.6	4.4	7.9	4.6	2.2	2.3	2.3	3.1
3 Axle Vehicles	1	1	2	38	3	41	7	17	24	67
% 3 Axle Vehicles	4.5	0.9	1.6	7.6	7.9	7.6	3.9	2.8	3.1	4.6
4+ Axle Trucks	1	6	7	37	1	38	9	40	49	94
% 4+ Axle Trucks	4.5	5.6	5.4	7.4	2.6	7	5.1	6.7	6.3	6.5

Start Time	Lena Road Southbound			Orange Show Road Westbound			Orange Show Road Eastbound			Int. Total
	Left	Right	App. Total	Thru	Right	App. Total	Left	Thru	App. Total	
Peak Hour Analysis From 07:00 AM to 08:45 AM - Peak 1 of 1										
Peak Hour for Entire Intersection Begins at 07:15 AM										
07:15 AM	1	5	6	56	2	58	22	78	100	164
07:30 AM	1	8	9	85	4	89	25	64	89	187
07:45 AM	2	11	13	68	9	77	35	95	130	220
08:00 AM	4	9	13	64	1	65	26	91	117	195
Total Volume	8	33	41	273	16	289	108	328	436	766
% App. Total	19.5	80.5		94.5	5.5		24.8	75.2		
PHF	.500	.750	.788	.803	.444	.812	.771	.863	.838	.870

City of San Bernardino
 N/S: Lena Road
 E/W: Orange Show Road
 Weather: Clear

File Name : 03_SBC_Lena_Orange AM
 Site Code : 99921278
 Start Date : 6/15/2021
 Page No : 2

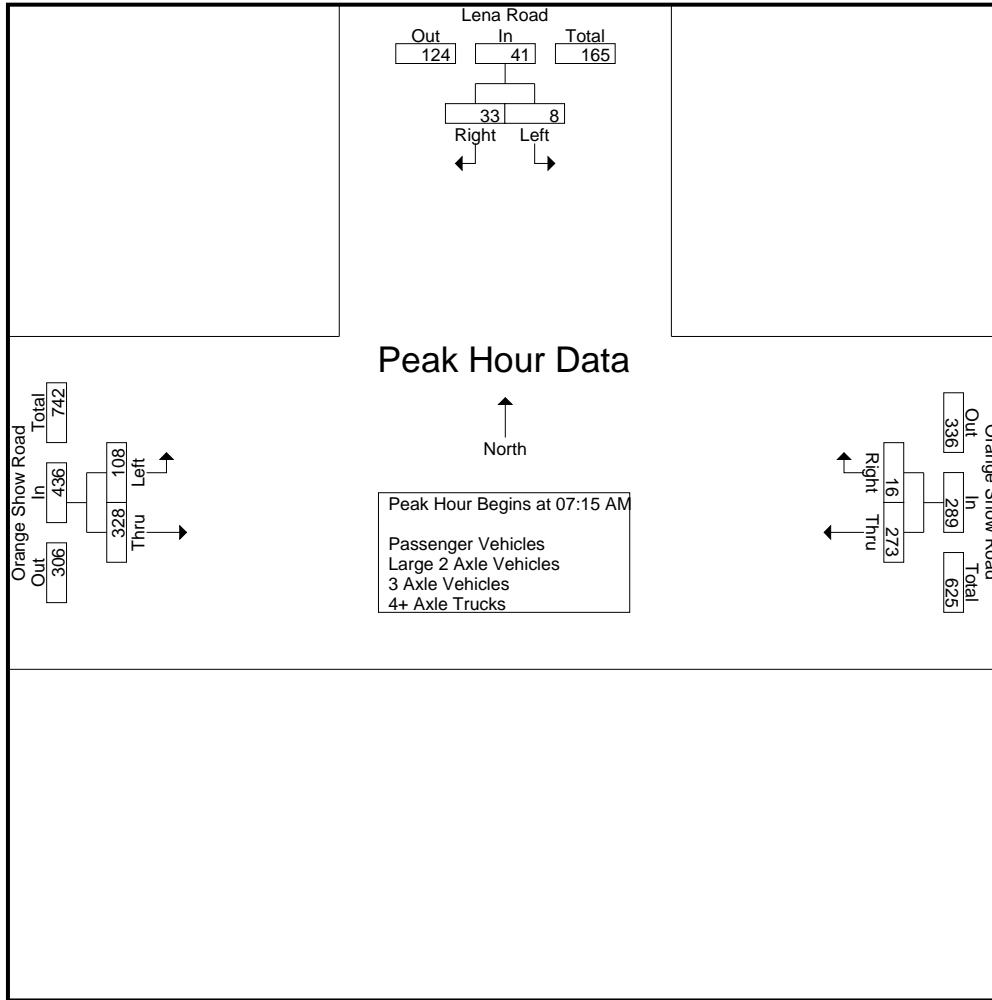

Peak Hour Analysis From 07:00 AM to 08:45 AM - Peak 1 of 1
 Peak Hour for Each Approach Begins at:

	08:00 AM			07:30 AM			07:15 AM		
+0 mins.	4	9	13	85	4	89	22	78	100
+15 mins.	1	12	13	68	9	77	25	64	89
+30 mins.	6	12	18	64	1	65	35	95	130
+45 mins.	5	40	45	62	4	66	26	91	117
Total Volume	16	73	89	279	18	297	108	328	436
% App. Total	18	82		93.9	6.1		24.8	75.2	
PHF	.667	.456	.494	.821	.500	.834	.771	.863	.838

City of San Bernardino
 N/S: Lena Road
 E/W: Orange Show Road
 Weather: Clear

File Name : 03_SBC_Lena_Orange AM
 Site Code : 99921278
 Start Date : 6/15/2021
 Page No : 1

Groups Printed- Passenger Vehicles

Start Time	Lena Road Southbound			Orange Show Road Westbound			Orange Show Road Eastbound			Int. Total
	Left	Right	App. Total	Thru	Right	App. Total	Left	Thru	App. Total	
07:00 AM	2	9	11	35	7	42	17	74	91	144
07:15 AM	1	5	6	45	0	45	21	74	95	146
07:30 AM	1	8	9	70	4	74	22	53	75	158
07:45 AM	2	10	12	55	8	63	31	86	117	192
Total	6	32	38	205	19	224	91	287	378	640
08:00 AM	4	7	11	58	1	59	23	80	103	173
08:15 AM	1	11	12	45	2	47	18	56	74	133
08:30 AM	6	11	17	44	4	48	13	52	65	130
08:45 AM	3	37	40	53	5	58	13	54	67	165
Total	14	66	80	200	12	212	67	242	309	601
Grand Total	20	98	118	405	31	436	158	529	687	1241
Apprch %	16.9	83.1		92.9	7.1		23	77		
Total %	1.6	7.9	9.5	32.6	2.5	35.1	12.7	42.6	55.4	

Start Time	Lena Road Southbound			Orange Show Road Westbound			Orange Show Road Eastbound			Int. Total
	Left	Right	App. Total	Thru	Right	App. Total	Left	Thru	App. Total	
07:15 AM	1	5	6	45	0	45	21	74	95	146
07:30 AM	1	8	9	70	4	74	22	53	75	158
07:45 AM	2	10	12	55	8	63	31	86	117	192
08:00 AM	4	7	11	58	1	59	23	80	103	173
Total Volume	8	30	38	228	13	241	97	293	390	669
% App. Total	21.1	78.9		94.6	5.4		24.9	75.1		
PHF	.500	.750	.792	.814	.406	.814	.782	.852	.833	.871

Peak Hour Analysis From 07:15 AM to 08:00 AM - Peak 1 of 1

Peak Hour for Entire Intersection Begins at 07:15 AM

City of San Bernardino
 N/S: Lena Road
 E/W: Orange Show Road
 Weather: Clear

File Name : 03_SBC_Lena_Orange AM
 Site Code : 99921278
 Start Date : 6/15/2021
 Page No : 2

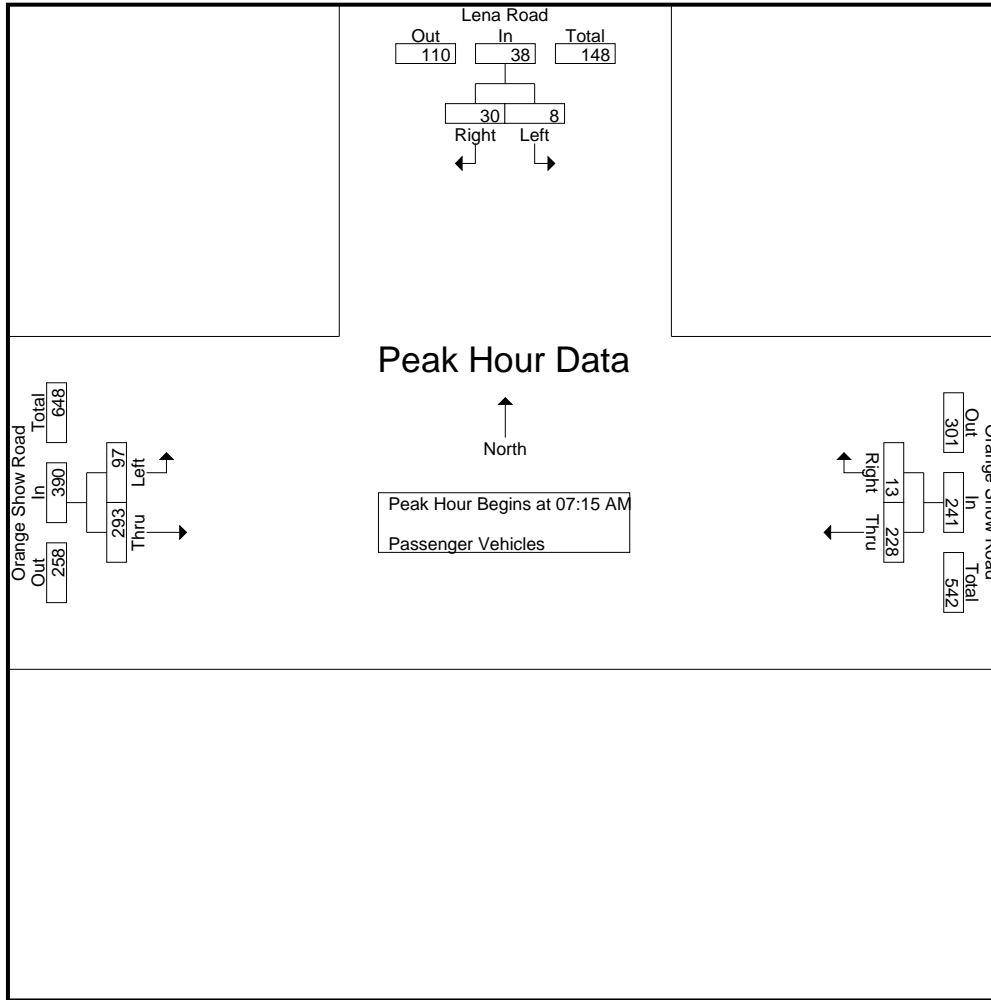

Peak Hour Analysis From 07:15 AM to 08:00 AM - Peak 1 of 1
 Peak Hour for Each Approach Begins at:

	07:15 AM			07:15 AM			07:15 AM		
+0 mins.	1	5	6	45	0	45	21	74	95
+15 mins.	1	8	9	70	4	74	22	53	75
+30 mins.	2	10	12	55	8	63	31	86	117
+45 mins.	4	7	11	58	1	59	23	80	103
Total Volume	8	30	38	228	13	241	97	293	390
% App. Total	21.1	78.9		94.6	5.4		24.9	75.1	
PHF	.500	.750	.792	.814	.406	.814	.782	.852	.833

City of San Bernardino
 N/S: Lena Road
 E/W: Orange Show Road
 Weather: Clear

File Name : 03_SBC_Lena_Orange AM
 Site Code : 99921278
 Start Date : 6/15/2021
 Page No : 1

Groups Printed- Large 2 Axle Vehicles

Start Time	Lena Road Southbound			Orange Show Road Westbound			Orange Show Road Eastbound			Int. Total
	Left	Right	App. Total	Thru	Right	App. Total	Left	Thru	App. Total	
07:00 AM	0	0	0	3	0	3	1	2	3	6
07:15 AM	0	0	0	3	2	5	1	1	2	7
07:30 AM	0	0	0	5	0	5	1	4	5	10
07:45 AM	0	1	1	2	0	2	1	0	1	4
Total	0	1	1	13	2	15	4	7	11	27
08:00 AM	0	0	0	2	0	2	0	3	3	5
08:15 AM	0	0	0	4	1	5	0	2	2	7
08:30 AM	0	1	1	1	0	1	0	1	1	3
08:45 AM	0	0	0	2	0	2	0	1	1	3
Total	0	1	1	9	1	10	0	7	7	18
Grand Total	0	2	2	22	3	25	4	14	18	45
Apprch %	0	100		88	12		22.2	77.8		
Total %	0	4.4	4.4	48.9	6.7	55.6	8.9	31.1	40	

Start Time	Lena Road Southbound			Orange Show Road Westbound			Orange Show Road Eastbound			Int. Total
	Left	Right	App. Total	Thru	Right	App. Total	Left	Thru	App. Total	
07:15 AM	0	0	0	3	2	5	1	1	2	7
07:30 AM	0	0	0	5	0	5	1	4	5	10
07:45 AM	0	1	1	2	0	2	1	0	1	4
08:00 AM	0	0	0	2	0	2	0	3	3	5
Total Volume	0	1	1	12	2	14	3	8	11	26
% App. Total	0	100		85.7	14.3		27.3	72.7		
PHF	.000	.250	.250	.600	.250	.700	.750	.500	.550	.650

Peak Hour Analysis From 07:15 AM to 08:00 AM - Peak 1 of 1

Peak Hour for Entire Intersection Begins at 07:15 AM

City of San Bernardino
 N/S: Lena Road
 E/W: Orange Show Road
 Weather: Clear

File Name : 03_SBC_Lena_Orange AM
 Site Code : 99921278
 Start Date : 6/15/2021
 Page No : 2

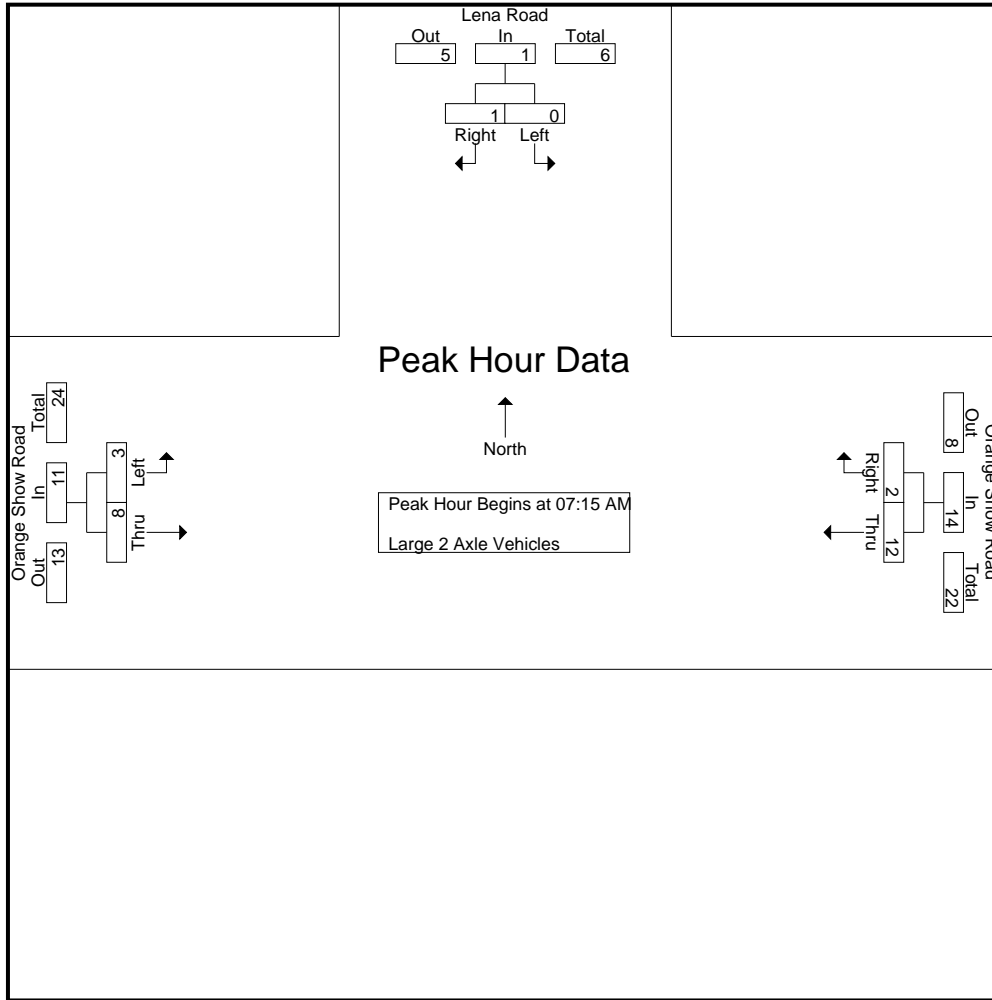

Peak Hour Analysis From 07:15 AM to 08:00 AM - Peak 1 of 1
 Peak Hour for Each Approach Begins at:

	07:15 AM			07:15 AM			07:15 AM		
+0 mins.	0	0	0	3	2	5	1	1	2
+15 mins.	0	0	0	5	0	5	1	4	5
+30 mins.	0	1	1	2	0	2	1	0	1
+45 mins.	0	0	0	2	0	2	0	3	3
Total Volume	0	1	1	12	2	14	3	8	11
% App. Total	0	100		85.7	14.3		27.3	72.7	
PHF	.000	.250	.250	.600	.250	.700	.750	.500	.550

City of San Bernardino
 N/S: Lena Road
 E/W: Orange Show Road
 Weather: Clear

File Name : 03_SBC_Lena_Orange AM
 Site Code : 99921278
 Start Date : 6/15/2021
 Page No : 1

Groups Printed- 3 Axle Vehicles

Start Time	Lena Road Southbound			Orange Show Road Westbound			Orange Show Road Eastbound			Int. Total
	Left	Right	App. Total	Thru	Right	App. Total	Left	Thru	App. Total	
07:00 AM	0	1	1	4	1	5	0	0	0	6
07:15 AM	0	0	0	2	0	2	0	1	1	3
07:30 AM	0	0	0	6	0	6	0	1	1	7
07:45 AM	0	0	0	9	0	9	1	4	5	14
Total	0	1	1	21	1	22	1	6	7	30
08:00 AM	0	0	0	3	0	3	2	3	5	8
08:15 AM	0	0	0	5	1	6	2	3	5	11
08:30 AM	0	0	0	2	1	3	2	2	4	7
08:45 AM	1	0	1	7	0	7	0	3	3	11
Total	1	0	1	17	2	19	6	11	17	37
Grand Total	1	1	2	38	3	41	7	17	24	67
Apprch %	50	50		92.7	7.3		29.2	70.8		
Total %	1.5	1.5	3	56.7	4.5	61.2	10.4	25.4	35.8	

Start Time	Lena Road Southbound			Orange Show Road Westbound			Orange Show Road Eastbound			Int. Total
	Left	Right	App. Total	Thru	Right	App. Total	Left	Thru	App. Total	
07:15 AM	0	0	0	2	0	2	0	1	1	3
07:30 AM	0	0	0	6	0	6	0	1	1	7
07:45 AM	0	0	0	9	0	9	1	4	5	14
08:00 AM	0	0	0	3	0	3	2	3	5	8
Total Volume	0	0	0	20	0	20	3	9	12	32
% App. Total	0	0		100	0		25	75		
PHF	.000	.000	.000	.556	.000	.556	.375	.563	.600	.571

Peak Hour Analysis From 07:15 AM to 08:00 AM - Peak 1 of 1

Peak Hour for Entire Intersection Begins at 07:15 AM

City of San Bernardino
 N/S: Lena Road
 E/W: Orange Show Road
 Weather: Clear

File Name : 03_SBC_Lena_Orange AM
 Site Code : 99921278
 Start Date : 6/15/2021
 Page No : 2

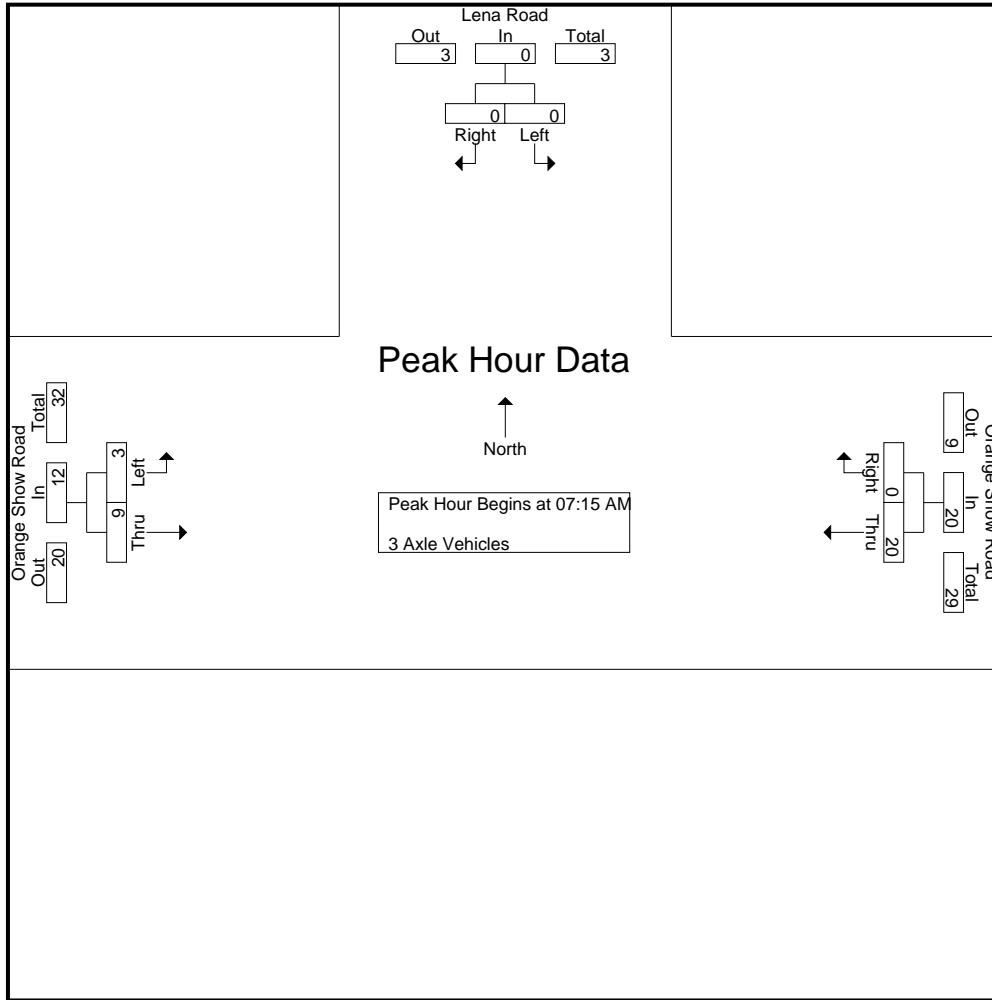

Peak Hour Analysis From 07:15 AM to 08:00 AM - Peak 1 of 1
 Peak Hour for Each Approach Begins at:

	07:15 AM			07:15 AM			07:15 AM		
+0 mins.	0	0	0	2	0	2	0	1	1
+15 mins.	0	0	0	6	0	6	0	1	1
+30 mins.	0	0	0	9	0	9	1	4	5
+45 mins.	0	0	0	3	0	3	2	3	5
Total Volume	0	0	0	20	0	20	3	9	12
% App. Total	0	0	0	100	0		25	75	
PHF	.000	.000	.000	.556	.000	.556	.375	.563	.600

City of San Bernardino
 N/S: Lena Road
 E/W: Orange Show Road
 Weather: Clear

File Name : 03_SBC_Lena_Orange AM
 Site Code : 99921278
 Start Date : 6/15/2021
 Page No : 1

Groups Printed- 4+ Axle Trucks

Start Time	Lena Road Southbound			Orange Show Road Westbound			Orange Show Road Eastbound			Int. Total
	Left	Right	App. Total	Thru	Right	App. Total	Left	Thru	App. Total	
07:00 AM	0	0	0	4	0	4	0	5	5	9
07:15 AM	0	0	0	6	0	6	0	2	2	8
07:30 AM	0	0	0	4	0	4	2	6	8	12
07:45 AM	0	0	0	2	1	3	2	5	7	10
Total	0	0	0	16	1	17	4	18	22	39
08:00 AM	0	2	2	1	0	1	1	5	6	9
08:15 AM	0	1	1	8	0	8	0	4	4	13
08:30 AM	0	0	0	5	0	5	3	5	8	13
08:45 AM	1	3	4	7	0	7	1	8	9	20
Total	1	6	7	21	0	21	5	22	27	55
Grand Total	1	6	7	37	1	38	9	40	49	94
Apprch %	14.3	85.7		97.4	2.6		18.4	81.6		
Total %	1.1	6.4	7.4	39.4	1.1	40.4	9.6	42.6	52.1	

Start Time	Lena Road Southbound			Orange Show Road Westbound			Orange Show Road Eastbound			Int. Total
	Left	Right	App. Total	Thru	Right	App. Total	Left	Thru	App. Total	
07:15 AM	0	0	0	6	0	6	0	2	2	8
07:30 AM	0	0	0	4	0	4	2	6	8	12
07:45 AM	0	0	0	2	1	3	2	5	7	10
08:00 AM	0	2	2	1	0	1	1	5	6	9
Total Volume	0	2	2	13	1	14	5	18	23	39
% App. Total	0	100		92.9	7.1		21.7	78.3		
PHF	.000	.250	.250	.542	.250	.583	.625	.750	.719	.813

Peak Hour Analysis From 07:15 AM to 08:00 AM - Peak 1 of 1

Peak Hour for Entire Intersection Begins at 07:15 AM

City of San Bernardino
 N/S: Lena Road
 E/W: Orange Show Road
 Weather: Clear

File Name : 03_SBC_Lena_Orange AM
 Site Code : 99921278
 Start Date : 6/15/2021
 Page No : 2

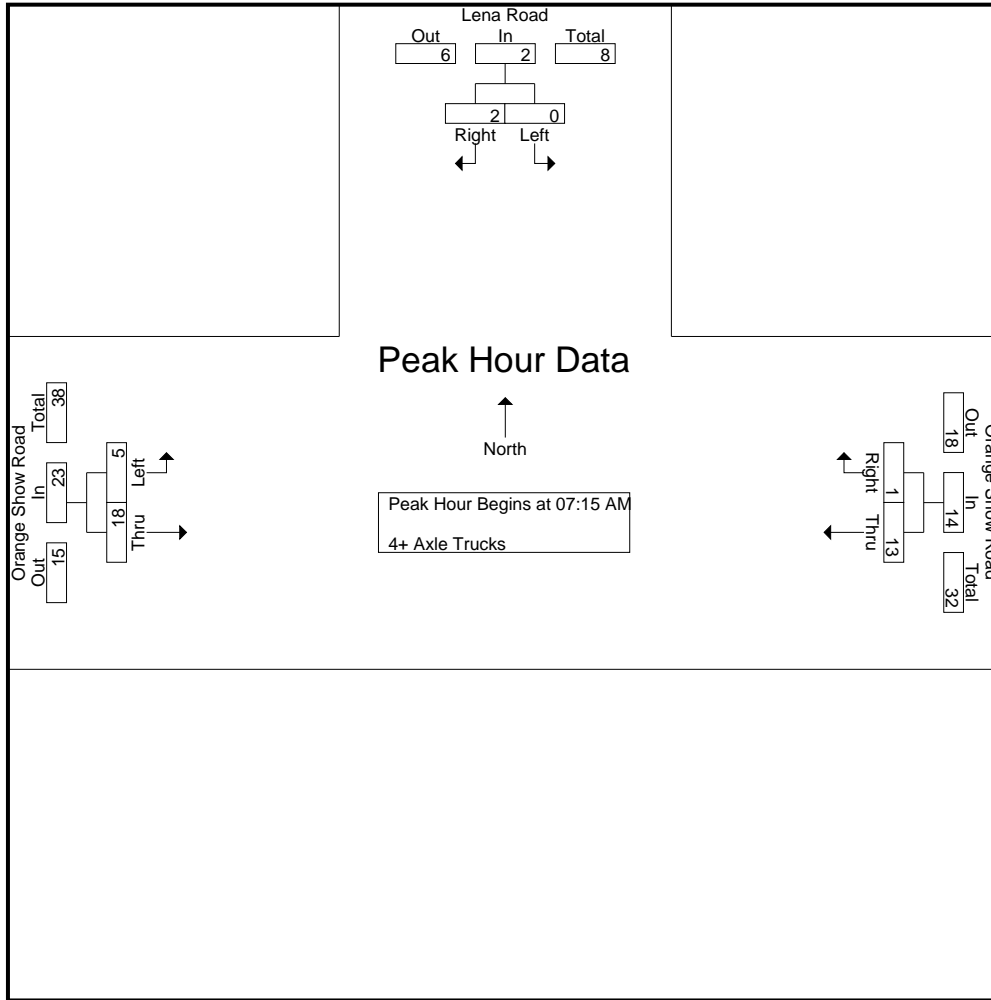

Peak Hour Analysis From 07:15 AM to 08:00 AM - Peak 1 of 1
 Peak Hour for Each Approach Begins at:

	07:15 AM			07:15 AM			07:15 AM		
+0 mins.	0	0	0	6	0	6	0	2	2
+15 mins.	0	0	0	4	0	4	2	6	8
+30 mins.	0	0	0	2	1	3	2	5	7
+45 mins.	0	2	2	1	0	1	1	5	6
Total Volume	0	2	2	13	1	14	5	18	23
% App. Total	0	100		92.9	7.1		21.7	78.3	
PHF	.000	.250	.250	.542	.250	.583	.625	.750	.719

City of San Bernardino
 N/S: Lena Road
 E/W: Orange Show Road
 Weather: Clear

File Name : 03_SBC_Lena_Orange PM
 Site Code : 99921278
 Start Date : 6/15/2021
 Page No : 1

Groups Printed- Passenger Vehicles - Large 2 Axle Vehicles - 3 Axle Vehicles - 4+ Axle Trucks

Start Time	Lena Road Southbound			Orange Show Road Westbound			Orange Show Road Eastbound			Int. Total
	Left	Right	App. Total	Thru	Right	App. Total	Left	Thru	App. Total	
04:00 PM	2	17	19	117	4	121	26	107	133	273
04:15 PM	4	13	17	79	3	82	22	105	127	226
04:30 PM	6	34	40	153	10	163	27	118	145	348
04:45 PM	1	16	17	87	7	94	35	88	123	234
Total	13	80	93	436	24	460	110	418	528	1081
05:00 PM	5	19	24	99	1	100	23	137	160	284
05:15 PM	1	11	12	76	6	82	26	140	166	260
05:30 PM	1	19	20	78	5	83	20	115	135	238
05:45 PM	0	14	14	56	3	59	23	121	144	217
Total	7	63	70	309	15	324	92	513	605	999
Grand Total	20	143	163	745	39	784	202	931	1133	2080
Apprch %	12.3	87.7		95	5		17.8	82.2		
Total %	1	6.9	7.8	35.8	1.9	37.7	9.7	44.8	54.5	
Passenger Vehicles	20	135	155	656	33	689	174	834	1008	1852
% Passenger Vehicles	100	94.4	95.1	88.1	84.6	87.9	86.1	89.6	89	89
Large 2 Axle Vehicles	0	3	3	8	2	10	10	32	42	55
% Large 2 Axle Vehicles	0	2.1	1.8	1.1	5.1	1.3	5	3.4	3.7	2.6
3 Axle Vehicles	0	2	2	26	0	26	11	22	33	61
% 3 Axle Vehicles	0	1.4	1.2	3.5	0	3.3	5.4	2.4	2.9	2.9
4+ Axle Trucks	0	3	3	55	4	59	7	43	50	112
% 4+ Axle Trucks	0	2.1	1.8	7.4	10.3	7.5	3.5	4.6	4.4	5.4

Start Time	Lena Road Southbound			Orange Show Road Westbound			Orange Show Road Eastbound			Int. Total
	Left	Right	App. Total	Thru	Right	App. Total	Left	Thru	App. Total	
Peak Hour Analysis From 04:00 PM to 05:45 PM - Peak 1 of 1										
Peak Hour for Entire Intersection Begins at 04:30 PM										
04:30 PM	6	34	40	153	10	163	27	118	145	348
04:45 PM	1	16	17	87	7	94	35	88	123	234
05:00 PM	5	19	24	99	1	100	23	137	160	284
05:15 PM	1	11	12	76	6	82	26	140	166	260
Total Volume	13	80	93	415	24	439	111	483	594	1126
% App. Total	14	86		94.5	5.5		18.7	81.3		
PHF	.542	.588	.581	.678	.600	.673	.793	.863	.895	.809

City of San Bernardino
 N/S: Lena Road
 E/W: Orange Show Road
 Weather: Clear

File Name : 03_SBC_Lena_Orange PM
 Site Code : 99921278
 Start Date : 6/15/2021
 Page No : 2

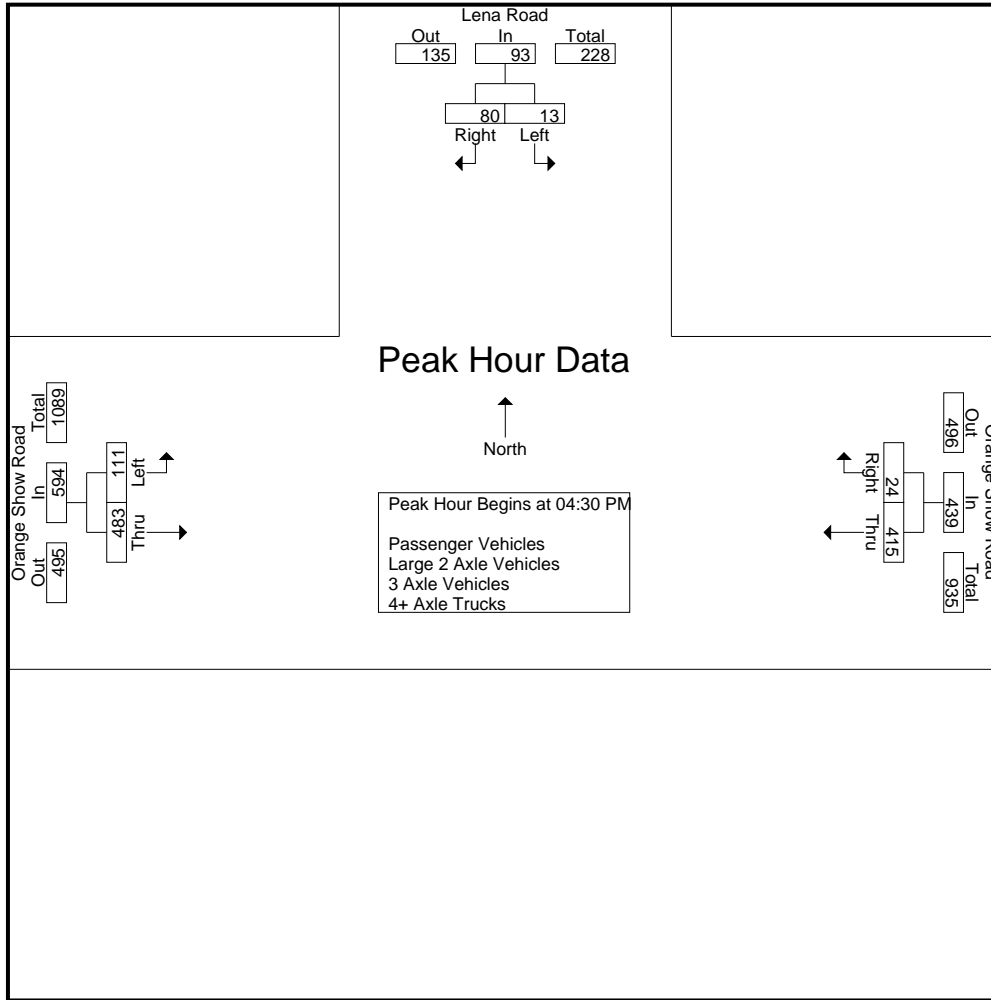

Peak Hour Analysis From 04:00 PM to 05:45 PM - Peak 1 of 1
 Peak Hour for Each Approach Begins at:

	04:15 PM			04:00 PM			05:00 PM		
+0 mins.	4	13	17	117	4	121	23	137	160
+15 mins.	6	34	40	79	3	82	26	140	166
+30 mins.	1	16	17	153	10	163	20	115	135
+45 mins.	5	19	24	87	7	94	23	121	144
Total Volume	16	82	98	436	24	460	92	513	605
% App. Total	16.3	83.7		94.8	5.2		15.2	84.8	
PHF	.667	.603	.613	.712	.600	.706	.885	.916	.911

City of San Bernardino
 N/S: Lena Road
 E/W: Orange Show Road
 Weather: Clear

File Name : 03_SBC_Lena_Orange PM
 Site Code : 99921278
 Start Date : 6/15/2021
 Page No : 1

Groups Printed- Passenger Vehicles

Start Time	Lena Road Southbound			Orange Show Road Westbound			Orange Show Road Eastbound			Int. Total
	Left	Right	App. Total	Thru	Right	App. Total	Left	Thru	App. Total	
04:00 PM	2	16	18	107	4	111	20	93	113	242
04:15 PM	4	13	17	67	3	70	19	95	114	201
04:30 PM	6	33	39	140	9	149	25	101	126	314
04:45 PM	1	15	16	78	5	83	30	80	110	209
Total	13	77	90	392	21	413	94	369	463	966
05:00 PM	5	18	23	85	1	86	22	127	149	258
05:15 PM	1	11	12	63	5	68	23	127	150	230
05:30 PM	1	16	17	69	3	72	14	100	114	203
05:45 PM	0	13	13	47	3	50	21	111	132	195
Total	7	58	65	264	12	276	80	465	545	886
Grand Total	20	135	155	656	33	689	174	834	1008	1852
Apprch %	12.9	87.1		95.2	4.8		17.3	82.7		
Total %	1.1	7.3	8.4	35.4	1.8	37.2	9.4	45	54.4	

Start Time	Lena Road Southbound			Orange Show Road Westbound			Orange Show Road Eastbound			Int. Total
	Left	Right	App. Total	Thru	Right	App. Total	Left	Thru	App. Total	
04:30 PM	6	33	39	140	9	149	25	101	126	314
04:45 PM	1	15	16	78	5	83	30	80	110	209
05:00 PM	5	18	23	85	1	86	22	127	149	258
05:15 PM	1	11	12	63	5	68	23	127	150	230
Total Volume	13	77	90	366	20	386	100	435	535	1011
% App. Total	14.4	85.6		94.8	5.2		18.7	81.3		
PHF	.542	.583	.577	.654	.556	.648	.833	.856	.892	.805

Peak Hour Analysis From 04:30 PM to 05:15 PM - Peak 1 of 1
 Peak Hour for Entire Intersection Begins at 04:30 PM

City of San Bernardino
 N/S: Lena Road
 E/W: Orange Show Road
 Weather: Clear

File Name : 03_SBC_Lena_Orange PM
 Site Code : 99921278
 Start Date : 6/15/2021
 Page No : 2

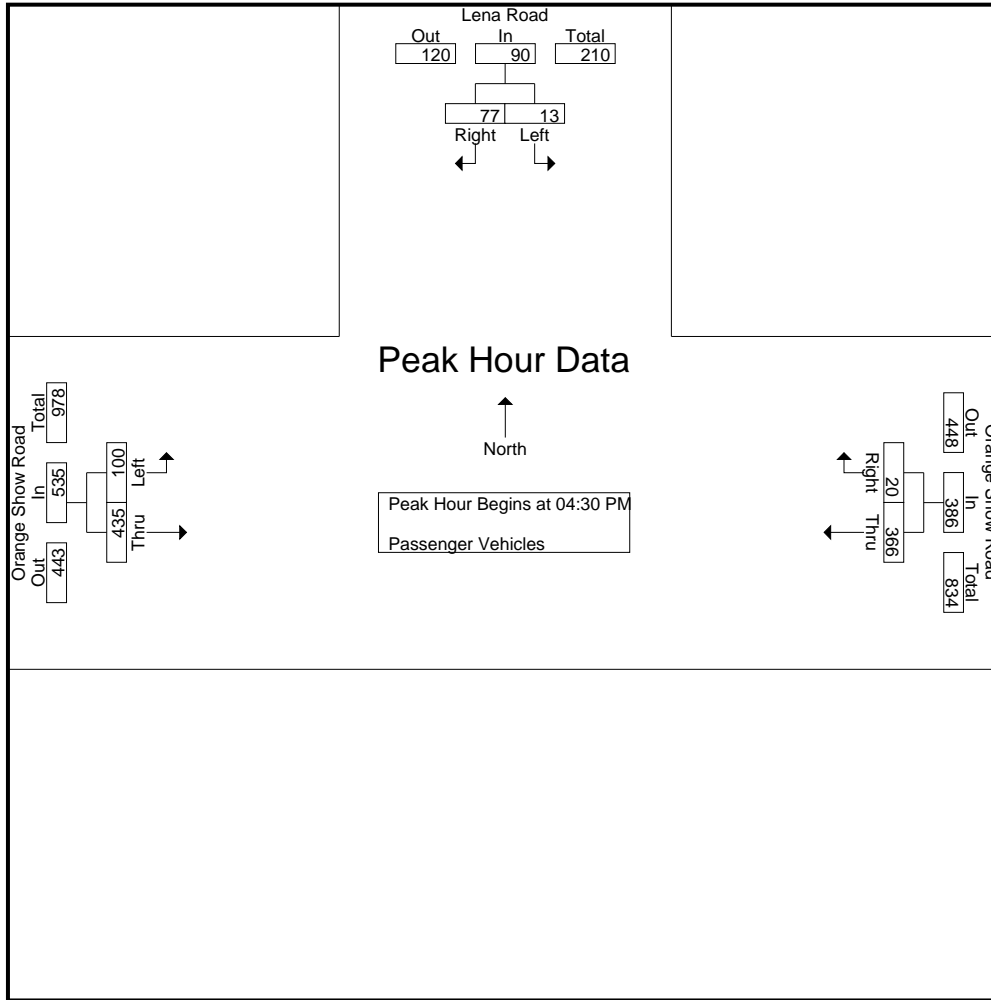

Peak Hour Analysis From 04:30 PM to 05:15 PM - Peak 1 of 1
 Peak Hour for Each Approach Begins at:

	04:30 PM			04:30 PM			04:30 PM		
+0 mins.	6	33	39	140	9	149	25	101	126
+15 mins.	1	15	16	78	5	83	30	80	110
+30 mins.	5	18	23	85	1	86	22	127	149
+45 mins.	1	11	12	63	5	68	23	127	150
Total Volume	13	77	90	366	20	386	100	435	535
% App. Total	14.4	85.6		94.8	5.2		18.7	81.3	
PHF	.542	.583	.577	.654	.556	.648	.833	.856	.892

City of San Bernardino
 N/S: Lena Road
 E/W: Orange Show Road
 Weather: Clear

File Name : 03_SBC_Lena_Orange PM
 Site Code : 99921278
 Start Date : 6/15/2021
 Page No : 1

Groups Printed- Large 2 Axle Vehicles

Start Time	Lena Road Southbound			Orange Show Road Westbound			Orange Show Road Eastbound			Int. Total
	Left	Right	App. Total	Thru	Right	App. Total	Left	Thru	App. Total	
04:00 PM	0	1	1	1	0	1	1	4	5	7
04:15 PM	0	0	0	1	0	1	0	4	4	5
04:30 PM	0	1	1	1	0	1	1	3	4	6
04:45 PM	0	0	0	1	1	2	4	3	7	9
Total	0	2	2	4	1	5	6	14	20	27
05:00 PM	0	0	0	2	0	2	0	3	3	5
05:15 PM	0	0	0	0	1	1	2	6	8	9
05:30 PM	0	1	1	1	0	1	1	6	7	9
05:45 PM	0	0	0	1	0	1	1	3	4	5
Total	0	1	1	4	1	5	4	18	22	28
Grand Total	0	3	3	8	2	10	10	32	42	55
Apprch %	0	100		80	20		23.8	76.2		
Total %	0	5.5	5.5	14.5	3.6	18.2	18.2	58.2	76.4	

Start Time	Lena Road Southbound			Orange Show Road Westbound			Orange Show Road Eastbound			Int. Total
	Left	Right	App. Total	Thru	Right	App. Total	Left	Thru	App. Total	
04:30 PM	0	1	1	1	0	1	1	3	4	6
04:45 PM	0	0	0	1	1	2	4	3	7	9
05:00 PM	0	0	0	2	0	2	0	3	3	5
05:15 PM	0	0	0	0	1	1	2	6	8	9
Total Volume	0	1	1	4	2	6	7	15	22	29
% App. Total	0	100		66.7	33.3		31.8	68.2		
PHF	.000	.250	.250	.500	.500	.750	.438	.625	.688	.806

Peak Hour Analysis From 04:30 PM to 05:15 PM - Peak 1 of 1

Peak Hour for Entire Intersection Begins at 04:30 PM

City of San Bernardino
 N/S: Lena Road
 E/W: Orange Show Road
 Weather: Clear

File Name : 03_SBC_Lena_Orange PM
 Site Code : 99921278
 Start Date : 6/15/2021
 Page No : 2

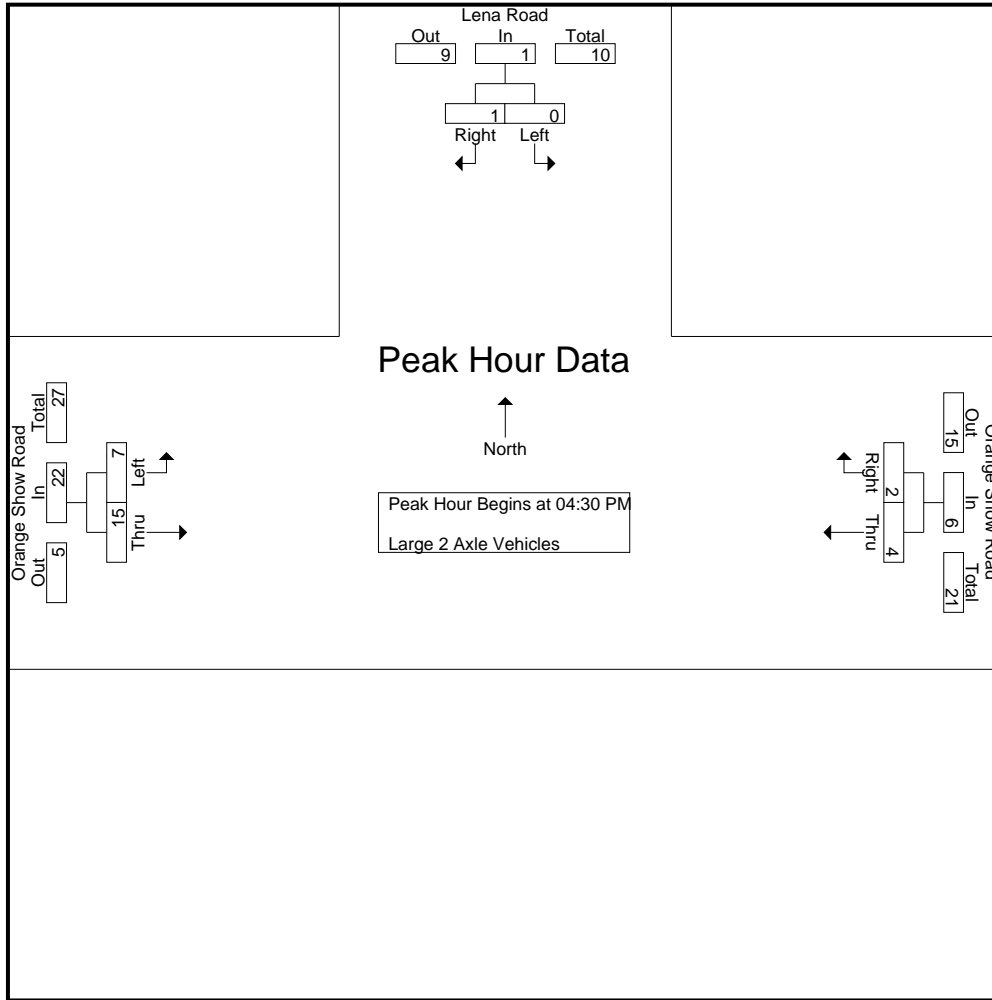

Peak Hour Analysis From 04:30 PM to 05:15 PM - Peak 1 of 1
 Peak Hour for Each Approach Begins at:

	04:30 PM			04:30 PM			04:30 PM		
+0 mins.	0	1	1	1	0	1	1	3	4
+15 mins.	0	0	0	1	1	2	4	3	7
+30 mins.	0	0	0	2	0	2	0	3	3
+45 mins.	0	0	0	0	1	1	2	6	8
Total Volume	0	1	1	4	2	6	7	15	22
% App. Total	0	100		66.7	33.3		31.8	68.2	
PHF	.000	.250	.250	.500	.500	.750	.438	.625	.688

City of San Bernardino
 N/S: Lena Road
 E/W: Orange Show Road
 Weather: Clear

File Name : 03_SBC_Lena_Orange PM
 Site Code : 99921278
 Start Date : 6/15/2021
 Page No : 1

Groups Printed- 3 Axle Vehicles

Start Time	Lena Road Southbound			Orange Show Road Westbound			Orange Show Road Eastbound			Int. Total
	Left	Right	App. Total	Thru	Right	App. Total	Left	Thru	App. Total	
04:00 PM	0	0	0	2	0	2	2	3	5	7
04:15 PM	0	0	0	3	0	3	3	3	6	9
04:30 PM	0	0	0	5	0	5	1	4	5	10
04:45 PM	0	0	0	2	0	2	1	1	2	4
Total	0	0	0	12	0	12	7	11	18	30
05:00 PM	0	0	0	3	0	3	0	3	3	6
05:15 PM	0	0	0	3	0	3	0	5	5	8
05:30 PM	0	1	1	2	0	2	3	3	6	9
05:45 PM	0	1	1	6	0	6	1	0	1	8
Total	0	2	2	14	0	14	4	11	15	31
Grand Total	0	2	2	26	0	26	11	22	33	61
Apprch %	0	100		100	0		33.3	66.7		
Total %	0	3.3	3.3	42.6	0	42.6	18	36.1	54.1	

Start Time	Lena Road Southbound			Orange Show Road Westbound			Orange Show Road Eastbound			Int. Total
	Left	Right	App. Total	Thru	Right	App. Total	Left	Thru	App. Total	
04:30 PM	0	0	0	5	0	5	1	4	5	10
04:45 PM	0	0	0	2	0	2	1	1	2	4
05:00 PM	0	0	0	3	0	3	0	3	3	6
05:15 PM	0	0	0	3	0	3	0	5	5	8
Total Volume	0	0	0	13	0	13	2	13	15	28
% App. Total	0	0		100	0		13.3	86.7		
PHF	.000	.000	.000	.650	.000	.650	.500	.650	.750	.700

Peak Hour Analysis From 04:30 PM to 05:15 PM - Peak 1 of 1

Peak Hour for Entire Intersection Begins at 04:30 PM

City of San Bernardino
 N/S: Lena Road
 E/W: Orange Show Road
 Weather: Clear

File Name : 03_SBC_Lena_Orange PM
 Site Code : 99921278
 Start Date : 6/15/2021
 Page No : 2

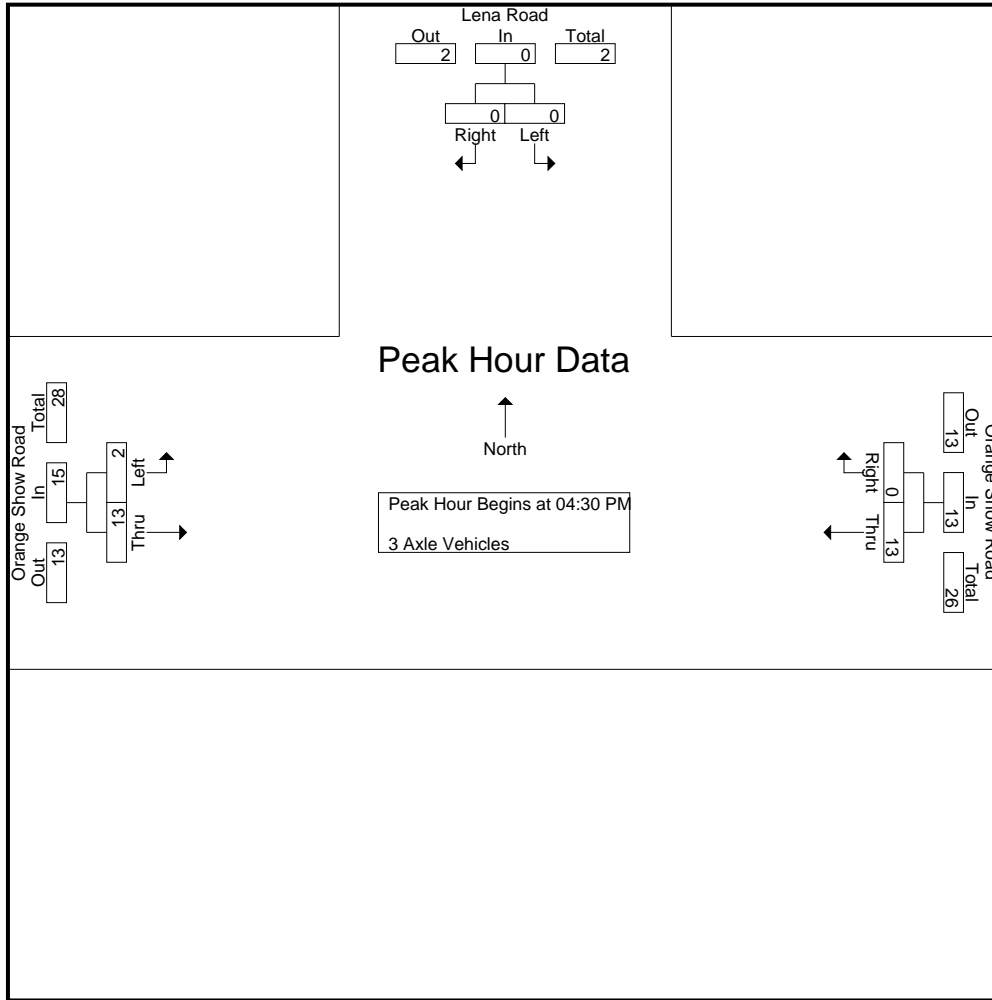

Peak Hour Analysis From 04:30 PM to 05:15 PM - Peak 1 of 1
 Peak Hour for Each Approach Begins at:

	04:30 PM			04:30 PM			04:30 PM		
+0 mins.	0	0	0	5	0	5	1	4	5
+15 mins.	0	0	0	2	0	2	1	1	2
+30 mins.	0	0	0	3	0	3	0	3	3
+45 mins.	0	0	0	3	0	3	0	5	5
Total Volume	0	0	0	13	0	13	2	13	15
% App. Total	0	0	0	100	0		13.3	86.7	
PHF	.000	.000	.000	.650	.000	.650	.500	.650	.750

City of San Bernardino
 N/S: Lena Road
 E/W: Orange Show Road
 Weather: Clear

File Name : 03_SBC_Lena_Orange PM
 Site Code : 99921278
 Start Date : 6/15/2021
 Page No : 1

Groups Printed- 4+ Axle Trucks

Start Time	Lena Road Southbound			Orange Show Road Westbound			Orange Show Road Eastbound			Int. Total
	Left	Right	App. Total	Thru	Right	App. Total	Left	Thru	App. Total	
04:00 PM	0	0	0	7	0	7	3	7	10	17
04:15 PM	0	0	0	8	0	8	0	3	3	11
04:30 PM	0	0	0	7	1	8	0	10	10	18
04:45 PM	0	1	1	6	1	7	0	4	4	12
Total	0	1	1	28	2	30	3	24	27	58
05:00 PM	0	1	1	9	0	9	1	4	5	15
05:15 PM	0	0	0	10	0	10	1	2	3	13
05:30 PM	0	1	1	6	2	8	2	6	8	17
05:45 PM	0	0	0	2	0	2	0	7	7	9
Total	0	2	2	27	2	29	4	19	23	54
Grand Total	0	3	3	55	4	59	7	43	50	112
Apprch %	0	100		93.2	6.8		14	86		
Total %	0	2.7	2.7	49.1	3.6	52.7	6.2	38.4	44.6	

Start Time	Lena Road Southbound			Orange Show Road Westbound			Orange Show Road Eastbound			Int. Total
	Left	Right	App. Total	Thru	Right	App. Total	Left	Thru	App. Total	
04:30 PM	0	0	0	7	1	8	0	10	10	18
04:45 PM	0	1	1	6	1	7	0	4	4	12
05:00 PM	0	1	1	9	0	9	1	4	5	15
05:15 PM	0	0	0	10	0	10	1	2	3	13
Total Volume	0	2	2	32	2	34	2	20	22	58
% App. Total	0	100		94.1	5.9		9.1	90.9		
PHF	.000	.500	.500	.800	.500	.850	.500	.500	.550	.806

Peak Hour Analysis From 04:30 PM to 05:15 PM - Peak 1 of 1

Peak Hour for Entire Intersection Begins at 04:30 PM

City of San Bernardino
 N/S: Lena Road
 E/W: Orange Show Road
 Weather: Clear

File Name : 03_SBC_Lena_Orange PM
 Site Code : 99921278
 Start Date : 6/15/2021
 Page No : 2

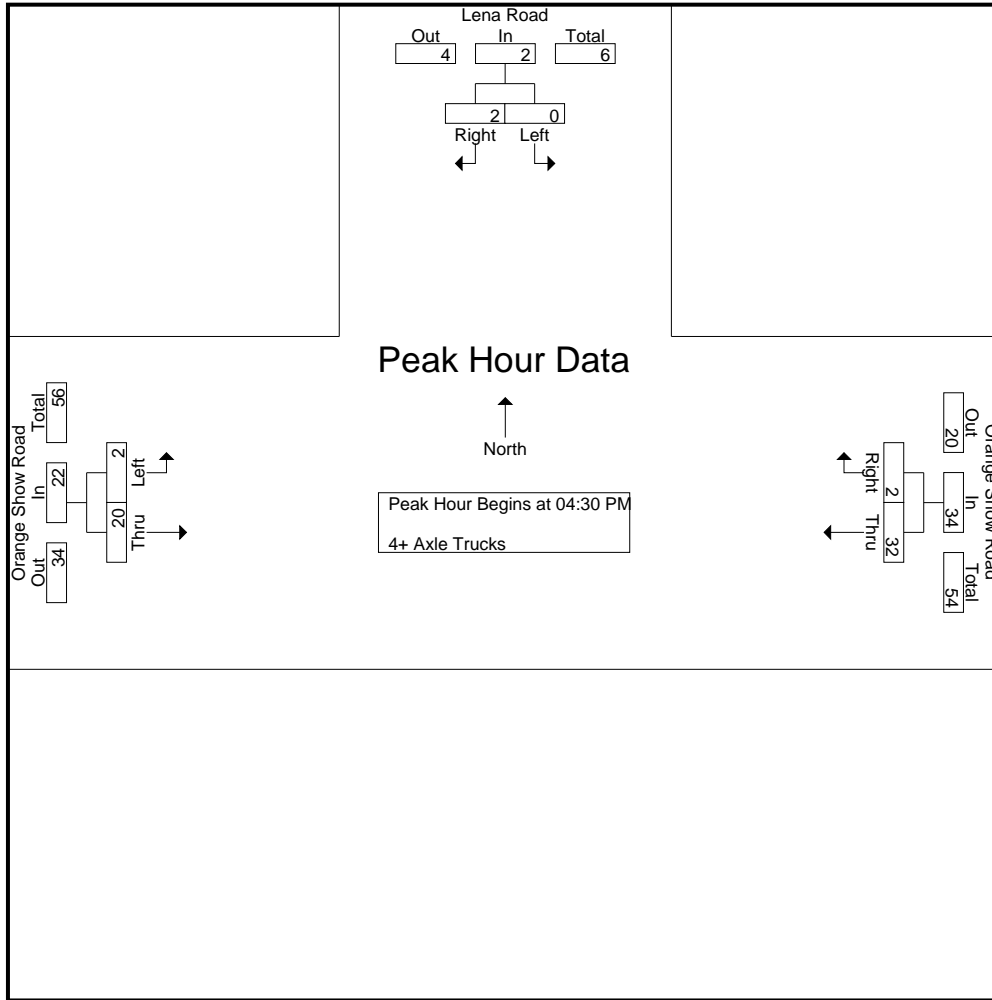

Peak Hour Analysis From 04:30 PM to 05:15 PM - Peak 1 of 1
 Peak Hour for Each Approach Begins at:

	04:30 PM			04:30 PM			04:30 PM		
+0 mins.	0	0	0	7	1	8	0	10	10
+15 mins.	0	1	1	6	1	7	0	4	4
+30 mins.	0	1	1	9	0	9	1	4	5
+45 mins.	0	0	0	10	0	10	1	2	3
Total Volume	0	2	2	32	2	34	2	20	22
% App. Total	0	100		94.1	5.9		9.1	90.9	
PHF	.000	.500	.500	.800	.500	.850	.500	.500	.550

APPENDIX B: VOLUME DEVELOPMENT WORKSHEETS

Table B-1: Existing Peak Hour Volumes
(Intersections With Classification Counts)

	AM Peak Hour					PM Peak Hour						
	Pass. Veh.	Trucks			Total PCE Volume	Pass. Veh.	Trucks			Total PCE Volume		
		2 Axle	3 Axle	4 Axle			PCE	2 Axle	3 Axle		4 Axle	PCE
2 . Foisy Street/Norman Road												
NBL	0	0	0	0	0	0	0	0	0	0	0	0
NBT	0	0	0	0	0	0	0	0	0	0	0	0
NBR	0	0	0	0	0	0	0	0	0	0	0	0
SBL	1	0	0	0	1	4	0	0	0	0	0	4
SBT	0	0	0	0	0	0	0	0	0	0	0	0
SBR	3	0	0	0	3	2	0	0	0	0	0	2
EBL	7	0	1	0	3	5	0	0	0	0	0	5
EBT	6	0	0	0	0	16	0	2	0	5	5	21
EBR	0	0	0	0	0	0	0	0	0	0	0	0
WBL	0	0	0	0	0	0	0	0	0	0	0	0
WBT	12	1	0	1	5	17	16	1	1	1	8	24
WBR	2	0	0	0	0	2	2	0	0	0	0	2
North Leg												
Approach	4	0	0	0	0	4	6	0	0	0	0	6
Departure	9	0	1	0	3	12	7	0	0	0	0	7
Total	13	0	1	0	3	16	13	0	0	0	0	13
South Leg												
Approach	0	0	0	0	0	0	0	0	0	0	0	0
Departure	0	0	0	0	0	0	0	0	0	0	0	0
Total	0	0	0	0	0	0	0	0	0	0	0	0
East Leg												
Approach	14	1	0	1	5	19	18	1	1	1	8	26
Departure	7	0	0	0	0	7	20	0	2	0	5	25
Total	21	1	0	1	5	26	38	1	3	1	13	51
West Leg												
Approach	13	0	1	0	3	16	21	0	2	0	5	26
Departure	15	1	0	1	5	20	18	1	1	1	8	26
Total	28	1	1	1	8	36	39	1	3	1	13	52
Total Approaches												
Approach	31	1	1	1	8	39	45	1	3	1	13	58
Departure	31	1	1	1	8	39	45	1	3	1	13	58
Total	62	2	2	2	16	78	90	2	6	2	26	116

Table B-1: Existing Peak Hour Volumes
(Intersections With Classification Counts)

	AM Peak Hour					PM Peak Hour						
	Pass. Veh.	Trucks			Total PCE Volume	Pass. Veh.	Trucks			Total PCE Volume		
		2 Axle	3 Axle	4 Axle			PCE	2 Axle	3 Axle		4 Axle	PCE
4 . Lena Road/Central Avenue												
NBL	11	0	1	1	6	17	13	1	0	0	2	15
NBT	29	0	0	1	3	32	42	2	0	0	4	46
NBR	48	2	2	5	24	72	27	3	1	3	18	45
SBL	6	0	0	0	0	6	9	0	0	0	0	9
SBT	10	0	0	0	0	10	31	1	0	0	2	33
SBR	10	0	0	0	0	10	7	1	0	0	2	9
EBL	8	0	0	0	0	8	10	0	0	0	0	10
EBT	143	1	2	3	16	159	151	3	3	3	23	174
EBR	3	0	0	1	3	6	17	0	0	0	0	17
WBL	17	0	0	3	9	26	19	0	1	0	3	22
WBT	134	3	7	11	57	191	224	4	10	4	45	269
WBR	8	0	0	0	0	8	6	0	0	0	0	6
North Leg												
Approach	26	0	0	0	0	26	47	2	0	0	4	51
Departure	45	0	0	1	3	48	58	2	0	0	4	62
Total	71	0	0	1	3	74	105	4	0	0	8	113
South Leg												
Approach	88	2	3	7	33	121	82	6	1	3	24	106
Departure	30	0	0	4	12	42	67	1	1	0	5	72
Total	118	2	3	11	45	163	149	7	2	3	29	178
East Leg												
Approach	159	3	7	14	66	225	249	4	11	4	48	297
Departure	197	3	4	8	40	237	187	6	4	6	41	228
Total	356	6	11	22	106	462	436	10	15	10	89	525
West Leg												
Approach	154	1	2	4	19	173	178	3	3	3	23	201
Departure	155	3	8	12	63	218	244	6	10	4	49	293
Total	309	4	10	16	82	391	422	9	13	7	72	494
Total Approaches												
Approach	427	6	12	25	118	545	556	15	15	10	99	655
Departure	427	6	12	25	118	545	556	15	15	10	99	655
Total	854	12	24	50	236	1,090	1,112	30	30	20	198	1,310

**Table B-1: Existing Peak Hour Volumes
(Intersections With Classification Counts)**

	AM Peak Hour					PM Peak Hour					Total PCE Volume	
	Pass. Veh.	Trucks			PCE	Pass. Veh.	Trucks			PCE		
		2 Axle	3 Axle	4 Axle			2 Axle	3 Axle	4 Axle			
6 . Lena Road/Norman Road												
NBL	3	0	2	0	5	8	6	0	0	0	0	6
NBT	49	0	6	5	30	79	78	4	3	2	22	100
NBR	28	0	1	0	3	31	42	1	0	2	8	50
SBL	5	0	0	0	0	5	8	0	0	0	0	8
SBT	40	0	1	5	18	58	53	1	0	1	5	58
SBR	1	0	0	0	0	1	4	0	0	0	0	4
EBL	2	0	0	0	0	2	1	0	0	0	0	1
EBT	3	1	0	0	2	5	7	1	0	1	5	12
EBR	2	0	0	0	0	2	7	0	0	0	0	7
WBL	37	1	0	1	5	42	31	0	0	1	3	34
WBT	2	0	0	0	0	2	10	0	1	0	3	13
WBR	1	1	0	1	5	6	3	0	0	0	0	3
North Leg												
Approach	46	0	1	5	18	64	65	1	0	1	5	70
Departure	52	1	6	6	35	87	82	4	3	2	22	104
Total	98	1	7	11	53	151	147	5	3	3	27	174
South Leg												
Approach	80	0	9	5	38	118	126	5	3	4	30	156
Departure	79	1	1	6	23	102	91	1	0	2	8	99
Total	159	1	10	11	61	220	217	6	3	6	38	255
East Leg												
Approach	40	2	0	2	10	50	44	0	1	1	6	50
Departure	36	1	1	0	5	41	57	2	0	3	13	70
Total	76	3	1	2	15	91	101	2	1	4	19	120
West Leg												
Approach	7	1	0	0	2	9	15	1	0	1	5	20
Departure	6	0	2	0	5	11	20	0	1	0	3	23
Total	13	1	2	0	7	20	35	1	1	1	8	43
Total Approaches												
Approach	173	3	10	12	68	241	250	7	4	7	46	296
Departure	173	3	10	12	68	241	250	7	4	7	46	296
Total	346	6	20	24	136	482	500	14	8	14	92	592

Table B-1: Existing Peak Hour Volumes
(Intersections With Classification Counts)

	AM Peak Hour					PM Peak Hour						
	Pass. Veh.	Trucks			Total PCE Volume	Pass. Veh.	Trucks			Total PCE Volume		
		2 Axle	3 Axle	4 Axle			PCE	2 Axle	3 Axle		4 Axle	PCE
7 . Lena Road/Orange Show Road												
NBL	0	0	0	0	0	0	0	0	0	0	0	0
NBT	0	0	0	0	0	0	0	0	0	0	0	0
NBR	0	0	0	0	0	0	0	0	0	0	0	0
SBL	8	0	0	0	8	13	0	0	0	0	0	13
SBT	0	0	0	0	0	0	0	0	0	0	0	0
SBR	30	1	0	2	8	38	77	1	0	2	8	85
EBL	97	3	3	5	29	126	100	7	2	2	25	125
EBT	293	8	9	18	93	386	435	15	13	20	123	558
EBR	0	0	0	0	0	0	0	0	0	0	0	0
WBL	0	0	0	0	0	0	0	0	0	0	0	0
WBT	228	12	20	13	113	341	366	4	13	32	137	503
WBR	13	2	0	1	7	20	20	2	0	2	10	30
North Leg												
Approach	38	1	0	2	8	46	90	1	0	2	8	98
Departure	110	5	3	6	36	146	120	9	2	4	35	155
Total	148	6	3	8	44	192	210	10	2	6	43	253
South Leg												
Approach	0	0	0	0	0	0	0	0	0	0	0	0
Departure	0	0	0	0	0	0	0	0	0	0	0	0
Total	0	0	0	0	0	0	0	0	0	0	0	0
East Leg												
Approach	241	14	20	14	120	361	386	6	13	34	147	533
Departure	301	8	9	18	93	394	448	15	13	20	123	571
Total	542	22	29	32	213	755	834	21	26	54	270	1,104
West Leg												
Approach	390	11	12	23	122	512	535	22	15	22	148	683
Departure	258	13	20	15	121	379	443	5	13	34	145	588
Total	648	24	32	38	243	891	978	27	28	56	293	1,271
Total Approaches												
Approach	669	26	32	39	250	919	1,011	29	28	58	303	1,314
Departure	669	26	32	39	250	919	1,011	29	28	58	303	1,314
Total	1,338	52	64	78	500	1,838	2,022	58	56	116	606	2,628

Table B-2: Existing Peak Hour Truck Percentages

	AM Peak Hour				PM Peak Hour			
	Passenger Vehicles	Total Trucks	Total Vehicle Volume	Truck %	Passenger Vehicles	Total Trucks	Total Vehicle Volume	Truck %
2 . Foisy Street/Norman Road								
NBL	0	0	0	0.00%	0	0	0	0.00%
NBT	0	0	0	0.00%	0	0	0	0.00%
NBR	0	0	0	0.00%	0	0	0	0.00%
SBL	1	0	1	0.00%	4	0	4	0.00%
SBT	0	0	0	0.00%	0	0	0	0.00%
SBR	3	0	3	0.00%	2	0	2	0.00%
EBL	7	1	8	12.50%	5	0	5	0.00%
EBT	6	0	6	0.00%	16	2	18	11.11%
EBR	0	0	0	0.00%	0	0	0	0.00%
WBL	0	0	0	0.00%	0	0	0	0.00%
WBT	12	2	14	14.29%	16	3	19	15.79%
WBR	2	0	2	0.00%	2	0	2	0.00%
North Leg								
Approach	4	0	4		6	0	6	
Departure	9	1	10		7	0	7	
Total	13	1	14	7.1%	13	0	13	0.0%
South Leg								
Approach	0	0	0		0	0	0	
Departure	0	0	0		0	0	0	
Total	0	0	0	0.0%	0	0	0	0.0%
East Leg								
Approach	14	2	16		18	3	21	
Departure	7	0	7		20	2	22	
Total	21	2	23	8.7%	38	5	43	11.6%
West Leg								
Approach	13	1	14		21	2	23	
Departure	15	2	17		18	3	21	
Total	28	3	31	9.7%	39	5	44	11.4%
Total Approaches								
Approach	31	3	34		45	5	50	
Departure	31	3	34		45	5	50	
Total	62	6	68	8.8%	90	10	100	10.0%

Table B-2: Existing Peak Hour Truck Percentages

	AM Peak Hour				PM Peak Hour			
	Passenger Vehicles	Total Trucks	Total Vehicle Volume	Truck %	Passenger Vehicles	Total Trucks	Total Vehicle Volume	Truck %
4 . Lena Road/Central Avenue								
NBL	11	2	13	15.38%	13	1	14	7.14%
NBT	29	1	30	3.33%	42	2	44	4.55%
NBR	48	9	57	15.79%	27	7	34	20.59%
SBL	6	0	6	0.00%	9	0	9	0.00%
SBT	10	0	10	0.00%	31	1	32	3.13%
SBR	10	0	10	0.00%	7	1	8	12.50%
EBL	8	0	8	0.00%	10	0	10	0.00%
EBT	143	6	149	4.03%	151	9	160	5.63%
EBR	3	1	4	25.00%	17	0	17	0.00%
WBL	17	3	20	15.00%	19	1	20	5.00%
WBT	134	21	155	13.55%	224	18	242	7.44%
WBR	8	0	8	0.00%	6	0	6	0.00%
North Leg								
Approach	26	0	26		47	2	49	
Departure	45	1	46		58	2	60	
Total	71	1	72	1.4%	105	4	109	3.7%
South Leg								
Approach	88	12	100		82	10	92	
Departure	30	4	34		67	2	69	
Total	118	16	134	11.9%	149	12	161	7.5%
East Leg								
Approach	159	24	183		249	19	268	
Departure	197	15	212		187	16	203	
Total	356	39	395	9.9%	436	35	471	7.4%
West Leg								
Approach	154	7	161		178	9	187	
Departure	155	23	178		244	20	264	
Total	309	30	339	8.8%	422	29	451	6.4%
Total Approaches								
Approach	427	43	470		556	40	596	
Departure	427	43	470		556	40	596	
Total	854	86	940	9.1%	1,112	80	1,192	6.7%

Table B-2: Existing Peak Hour Truck Percentages

	AM Peak Hour				PM Peak Hour			
	Passenger Vehicles	Total Trucks	Total Vehicle Volume	Truck %	Passenger Vehicles	Total Trucks	Total Vehicle Volume	Truck %
6 . Lena Road/Norman Road								
NBL	3	2	5	40.00%	6	0	6	0.00%
NBT	49	11	60	18.33%	78	9	87	10.34%
NBR	28	1	29	3.45%	42	3	45	6.67%
SBL	5	0	5	0.00%	8	0	8	0.00%
SBT	40	6	46	13.04%	53	2	55	3.64%
SBR	1	0	1	0.00%	4	0	4	0.00%
EBL	2	0	2	0.00%	1	0	1	0.00%
EBT	3	1	4	25.00%	7	2	9	22.22%
EBR	2	0	2	0.00%	7	0	7	0.00%
WBL	37	2	39	5.13%	31	1	32	3.13%
WBT	2	0	2	0.00%	10	1	11	9.09%
WBR	1	2	3	66.67%	3	0	3	0.00%
North Leg								
Approach	46	6	52		65	2	67	
Departure	52	13	65		82	9	91	
Total	98	19	117	16.2%	147	11	158	7.0%
South Leg								
Approach	80	14	94		126	12	138	
Departure	79	8	87		91	3	94	
Total	159	22	181	12.2%	217	15	232	6.5%
East Leg								
Approach	40	4	44		44	2	46	
Departure	36	2	38		57	5	62	
Total	76	6	82	7.3%	101	7	108	6.5%
West Leg								
Approach	7	1	8		15	2	17	
Departure	6	2	8		20	1	21	
Total	13	3	16	18.8%	35	3	38	7.9%
Total Approaches								
Approach	173	25	198		250	18	268	
Departure	173	25	198		250	18	268	
Total	346	50	396	12.6%	500	36	536	6.7%

Table B-2: Existing Peak Hour Truck Percentages

	AM Peak Hour				PM Peak Hour			
	Passenger Vehicles	Total Trucks	Total Vehicle Volume	Truck %	Passenger Vehicles	Total Trucks	Total Vehicle Volume	Truck %
7 . Lena Road/Orange Show Road								
NBL	0	0	0	0.00%	0	0	0	0.00%
NBT	0	0	0	0.00%	0	0	0	0.00%
NBR	0	0	0	0.00%	0	0	0	0.00%
SBL	8	0	8	0.00%	13	0	13	0.00%
SBT	0	0	0	0.00%	0	0	0	0.00%
SBR	30	3	33	9.09%	77	3	80	3.75%
EBL	97	11	108	10.19%	100	11	111	9.91%
EBT	293	35	328	10.67%	435	48	483	9.94%
EBR	0	0	0	0.00%	0	0	0	0.00%
WBL	0	0	0	0.00%	0	0	0	0.00%
WBT	228	45	273	16.48%	366	49	415	11.81%
WBR	13	3	16	18.75%	20	4	24	16.67%
North Leg								
Approach	38	3	41		90	3	93	
Departure	110	14	124		120	15	135	
Total	148	17	165	10.3%	210	18	228	7.9%
South Leg								
Approach	0	0	0		0	0	0	
Departure	0	0	0		0	0	0	
Total	0	0	0	0.0%	0	0	0	0.0%
East Leg								
Approach	241	48	289		386	53	439	
Departure	301	35	336		448	48	496	
Total	542	83	625	13.3%	834	101	935	10.8%
West Leg								
Approach	390	46	436		535	59	594	
Departure	258	48	306		443	52	495	
Total	648	94	742	12.7%	978	111	1,089	10.2%
Total Approaches								
Approach	669	97	766		1,011	115	1,126	
Departure	669	97	766		1,011	115	1,126	
Total	1,338	194	1,532	12.7%	2,022	230	2,252	10.2%

Table B-3: Existing Peak Hour Volume Summary

	AM Peak Hour			PM Peak Hour		
	Exist PCE Volumes	Project Trips	Exist With Project	Exist PCE Volumes	Project Trips	Exist With Project
1 . Foisy Street/Driveway 1						
NBL	0	0	0	0	0	0
NBT	12	0	12	7	0	7
NBR	0	6	6	0	1	1
SBL	0	2	2	0	0	0
SBT	4	0	4	6	0	6
SBR	0	0	0	0	0	0
EBL	0	0	0	0	0	0
EBT	0	0	0	0	0	0
EBR	0	0	0	0	0	0
WBL	0	2	2	0	6	6
WBT	0	0	0	0	0	0
WBR	0	0	0	0	2	2
North Leg						
Approach	4	2	6	6	0	6
Departure	12	0	12	7	2	9
Total	16	2	18	13	2	15
South Leg						
Approach	12	6	18	7	1	8
Departure	4	2	6	6	6	12
Total	16	8	24	13	7	20
East Leg						
Approach	0	2	2	0	8	8
Departure	0	8	8	0	1	1
Total	0	10	10	0	9	9
West Leg						
Approach	0	0	0	0	0	0
Departure	0	0	0	0	0	0
Total	0	0	0	0	0	0
Total Approaches						
Approach	16	10	26	13	9	22
Departure	16	10	26	13	9	22
Total	32	20	52	26	18	44

Table B-3: Existing Peak Hour Volume Summary

	AM Peak Hour			PM Peak Hour		
	Exist PCE Volumes	Project Trips	Exist With Project	Exist PCE Volumes	Project Trips	Exist With Project
2 . Foisy Street/Norman Road						
NBL	0	0	0	0	0	0
NBT	0	0	0	0	0	0
NBR	0	0	0	0	0	0
SBL	1	0	1	4	1	5
SBT	0	0	0	0	0	0
SBR	3	2	5	2	5	7
EBL	10	5	15	5	1	6
EBT	6	2	8	21	0	21
EBR	0	0	0	0	0	0
WBL	0	0	0	0	0	0
WBT	17	0	17	24	2	26
WBR	2	1	3	2	0	2
North Leg						
Approach	4	2	6	6	6	12
Departure	12	6	18	7	1	8
Total	16	8	24	13	7	20
South Leg						
Approach	0	0	0	0	0	0
Departure	0	0	0	0	0	0
Total	0	0	0	0	0	0
East Leg						
Approach	19	1	20	26	2	28
Departure	7	2	9	25	1	26
Total	26	3	29	51	3	54
West Leg						
Approach	16	7	23	26	1	27
Departure	20	2	22	26	7	33
Total	36	9	45	52	8	60
Total Approaches						
Approach	39	10	49	58	9	67
Departure	39	10	49	58	9	67
Total	78	20	98	116	18	134

Table B-3: Existing Peak Hour Volume Summary

	AM Peak Hour			PM Peak Hour		
	Exist PCE Volumes	Project Trips	Exist With Project	Exist PCE Volumes	Project Trips	Exist With Project
3 . Driveway 2/Norman Road						
NBL	0	0	0	0	0	0
NBT	0	0	0	0	0	0
NBR	0	0	0	0	0	0
SBL	0	0	0	0	1	1
SBT	0	0	0	0	0	0
SBR	0	0	0	0	2	2
EBL	0	2	2	0	0	0
EBT	7	0	7	25	1	26
EBR	0	0	0	0	0	0
WBL	0	0	0	0	0	0
WBT	19	1	20	26	0	26
WBR	0	1	1	0	0	0
North Leg						
Approach	0	0	0	0	3	3
Departure	0	3	3	0	0	0
Total	0	3	3	0	3	3
South Leg						
Approach	0	0	0	0	0	0
Departure	0	0	0	0	0	0
Total	0	0	0	0	0	0
East Leg						
Approach	19	2	21	26	0	26
Departure	7	0	7	25	2	27
Total	26	2	28	51	2	53
West Leg						
Approach	7	2	9	25	1	26
Departure	19	1	20	26	2	28
Total	26	3	29	51	3	54
Total Approaches						
Approach	26	4	30	51	4	55
Departure	26	4	30	51	4	55
Total	52	8	60	102	8	110

Table B-3: Existing Peak Hour Volume Summary

	AM Peak Hour			PM Peak Hour		
	Exist PCE Volumes	Project Trips	Exist With Project	Exist PCE Volumes	Project Trips	Exist With Project
4 . Lena Road/Central Avenue						
NBL	17	5	22	15	4	19
NBT	32	0	32	46	0	46
NBR	72	0	72	45	1	46
SBL	6	0	6	9	0	9
SBT	10	0	10	33	0	33
SBR	10	0	10	9	0	9
EBL	8	0	8	10	0	10
EBT	159	0	159	174	0	174
EBR	6	5	11	17	2	19
WBL	26	1	27	22	0	22
WBT	191	0	191	269	0	269
WBR	8	0	8	6	0	6
North Leg						
Approach	26	0	26	51	0	51
Departure	48	0	48	62	0	62
Total	74	0	74	113	0	113
South Leg						
Approach	121	5	126	106	5	111
Departure	42	6	48	72	2	74
Total	163	11	174	178	7	185
East Leg						
Approach	225	1	226	297	0	297
Departure	237	0	237	228	1	229
Total	462	1	463	525	1	526
West Leg						
Approach	173	5	178	201	2	203
Departure	218	5	223	293	4	297
Total	391	10	401	494	6	500
Total Approaches						
Approach	545	11	556	655	7	662
Departure	545	11	556	655	7	662
Total	1,090	22	1,112	1,310	14	1,324

Table B-3: Existing Peak Hour Volume Summary

	AM Peak Hour			PM Peak Hour		
	Exist PCE Volumes	Project Trips	Exist With Project	Exist PCE Volumes	Project Trips	Exist With Project
5 . Lena Road/Driveway 3						
NBL	0	3	3	0	1	1
NBT	87	0	87	104	0	104
NBR	0	0	0	0	0	0
SBL	0	0	0	0	0	0
SBT	64	0	64	70	0	70
SBR	0	6	6	0	2	2
EBL	0	5	5	0	5	5
EBT	0	0	0	0	0	0
EBR	0	2	2	0	3	3
WBL	0	0	0	0	0	0
WBT	0	0	0	0	0	0
WBR	0	0	0	0	0	0
North Leg						
Approach	64	6	70	70	2	72
Departure	87	5	92	104	5	109
Total	151	11	162	174	7	181
South Leg						
Approach	87	3	90	104	1	105
Departure	64	2	66	70	3	73
Total	151	5	156	174	4	178
East Leg						
Approach	0	0	0	0	0	0
Departure	0	0	0	0	0	0
Total	0	0	0	0	0	0
West Leg						
Approach	0	7	7	0	8	8
Departure	0	9	9	0	3	3
Total	0	16	16	0	11	11
Total Approaches						
Approach	151	16	167	174	11	185
Departure	151	16	167	174	11	185
Total	302	32	334	348	22	370

Table B-3: Existing Peak Hour Volume Summary

	AM Peak Hour			PM Peak Hour		
	Exist PCE Volumes	Project Trips	Exist With Project	Exist PCE Volumes	Project Trips	Exist With Project
6 . Lena Road/Norman Road						
NBL	8	2	10	6	0	6
NBT	79	3	82	100	1	101
NBR	31	0	31	50	0	50
SBL	5	0	5	8	0	8
SBT	58	2	60	58	3	61
SBR	1	0	1	4	0	4
EBL	2	0	2	1	0	1
EBT	5	0	5	12	1	13
EBR	2	0	2	7	2	9
WBL	42	0	42	34	0	34
WBT	2	1	3	13	0	13
WBR	6	0	6	3	0	3
North Leg						
Approach	64	2	66	70	3	73
Departure	87	3	90	104	1	105
Total	151	5	156	174	4	178
South Leg						
Approach	118	5	123	156	1	157
Departure	102	2	104	99	5	104
Total	220	7	227	255	6	261
East Leg						
Approach	50	1	51	50	0	50
Departure	41	0	41	70	1	71
Total	91	1	92	120	1	121
West Leg						
Approach	9	0	9	20	3	23
Departure	11	3	14	23	0	23
Total	20	3	23	43	3	46
Total Approaches						
Approach	241	8	249	296	7	303
Departure	241	8	249	296	7	303
Total	482	16	498	592	14	606

Table B-3: Existing Peak Hour Volume Summary

	AM Peak Hour			PM Peak Hour		
	Exist PCE Volumes	Project Trips	Exist With Project	Exist PCE Volumes	Project Trips	Exist With Project
7 . Lena Road/Orange Show Road						
NBL	0	0	0	0	0	0
NBT	0	0	0	0	0	0
NBR	0	0	0	0	0	0
SBL	8	0	8	13	1	14
SBT	0	0	0	0	0	0
SBR	38	2	40	85	4	89
EBL	126	4	130	125	1	126
EBT	386	0	386	558	0	558
EBR	0	0	0	0	0	0
WBL	0	0	0	0	0	0
WBT	341	0	341	503	0	503
WBR	20	1	21	30	0	30
North Leg						
Approach	46	2	48	98	5	103
Departure	146	5	151	155	1	156
Total	192	7	199	253	6	259
South Leg						
Approach	0	0	0	0	0	0
Departure	0	0	0	0	0	0
Total	0	0	0	0	0	0
East Leg						
Approach	361	1	362	533	0	533
Departure	394	0	394	571	1	572
Total	755	1	756	1,104	1	1,105
West Leg						
Approach	512	4	516	683	1	684
Departure	379	2	381	588	4	592
Total	891	6	897	1,271	5	1,276
Total Approaches						
Approach	919	7	926	1,314	6	1,320
Departure	919	7	926	1,314	6	1,320
Total	1,838	14	1,852	2,628	12	2,640

Table B-4: Opening Year (2023) Base Peak Hour Volume Summary

	AM Peak Hour					PM Peak Hour				
	Exist PCE Volumes	Growth	OY Base	Project Trips	Exist With Project	Exist PCE Volumes	Growth	OY Base	Project Trips	Exist With Project
1 . Foisy Street/Driveway 1										
NBL	0	0	0	0	0	0	0	0	0	0
NBT	12	1	13	0	13	7	0	7	0	7
NBR	0	0	0	6	6	0	0	0	1	1
SBL	0	0	0	2	2	0	0	0	0	0
SBT	4	0	4	0	4	6	0	6	0	6
SBR	0	0	0	0	0	0	0	0	0	0
EBL	0	0	0	0	0	0	0	0	0	0
EBT	0	0	0	0	0	0	0	0	0	0
EBR	0	0	0	0	0	0	0	0	0	0
WBL	0	0	0	2	2	0	0	0	6	6
WBT	0	0	0	0	0	0	0	0	0	0
WBR	0	0	0	0	0	0	0	0	2	2
North Leg										
Approach	4	0	4	2	6	6	0	6	0	6
Departure	12	1	13	0	13	7	0	7	2	9
Total	16	1	17	2	19	13	0	13	2	15
South Leg										
Approach	12	1	13	6	19	7	0	7	1	8
Departure	4	0	4	2	6	6	0	6	6	12
Total	16	1	17	8	25	13	0	13	7	20
East Leg										
Approach	0	0	0	2	2	0	0	0	8	8
Departure	0	0	0	8	8	0	0	0	1	1
Total	0	0	0	10	10	0	0	0	9	9
West Leg										
Approach	0	0	0	0	0	0	0	0	0	0
Departure	0	0	0	0	0	0	0	0	0	0
Total	0	0	0	0	0	0	0	0	0	0
Total Approaches										
Approach	16	1	17	10	27	13	0	13	9	22
Departure	16	1	17	10	27	13	0	13	9	22
Total	32	2	34	20	54	26	0	26	18	44

Table B-4: Opening Year (2023) Base Peak Hour Volume Summary

	AM Peak Hour					PM Peak Hour				
	Exist PCE Volumes	Growth	OY Base	Project Trips	Exist With Project	Exist PCE Volumes	Growth	OY Base	Project Trips	Exist With Project
2 . Foisy Street/Norman Road										
NBL	0	0	0	0	0	0	0	0	0	0
NBT	0	0	0	0	0	0	0	0	0	0
NBR	0	0	0	0	0	0	0	0	0	0
SBL	1	0	1	0	1	4	0	4	1	5
SBT	0	0	0	0	0	0	0	0	0	0
SBR	3	0	3	2	5	2	0	2	5	7
EBL	10	1	11	5	16	5	0	5	1	6
EBT	6	0	6	2	8	21	1	22	0	22
EBR	0	0	0	0	0	0	0	0	0	0
WBL	0	0	0	0	0	0	0	0	0	0
WBT	17	1	18	0	18	24	1	25	2	27
WBR	2	0	2	1	3	2	0	2	0	2
North Leg										
Approach	4	0	4	2	6	6	0	6	6	12
Departure	12	1	13	6	19	7	0	7	1	8
Total	16	1	17	8	25	13	0	13	7	20
South Leg										
Approach	0	0	0	0	0	0	0	0	0	0
Departure	0	0	0	0	0	0	0	0	0	0
Total	0	0	0	0	0	0	0	0	0	0
East Leg										
Approach	19	1	20	1	21	26	1	27	2	29
Departure	7	0	7	2	9	25	1	26	1	27
Total	26	1	27	3	30	51	2	53	3	56
West Leg										
Approach	16	1	17	7	24	26	1	27	1	28
Departure	20	1	21	2	23	26	1	27	7	34
Total	36	2	38	9	47	52	2	54	8	62
Total Approaches										
Approach	39	2	41	10	51	58	2	60	9	69
Departure	39	2	41	10	51	58	2	60	9	69
Total	78	4	82	20	102	116	4	120	18	138

Table B-4: Opening Year (2023) Base Peak Hour Volume Summary

	AM Peak Hour					PM Peak Hour				
	Exist PCE Volumes	Growth	OY Base	Project Trips	Exist With Project	Exist PCE Volumes	Growth	OY Base	Project Trips	Exist With Project
3 . Driveway 2/Norman Road										
NBL	0	0	0	0	0	0	0	0	0	0
NBT	0	0	0	0	0	0	0	0	0	0
NBR	0	0	0	0	0	0	0	0	0	0
SBL	0	0	0	0	0	0	0	0	1	1
SBT	0	0	0	0	0	0	0	0	0	0
SBR	0	0	0	0	0	0	0	0	2	2
EBL	0	0	0	2	2	0	0	0	0	0
EBT	7	0	7	0	7	25	2	27	1	28
EBR	0	0	0	0	0	0	0	0	0	0
WBL	0	0	0	0	0	0	0	0	0	0
WBT	19	1	20	1	21	26	2	28	0	28
WBR	0	0	0	1	1	0	0	0	0	0
North Leg										
Approach	0	0	0	0	0	0	0	0	3	3
Departure	0	0	0	3	3	0	0	0	0	0
Total	0	0	0	3	3	0	0	0	3	3
South Leg										
Approach	0	0	0	0	0	0	0	0	0	0
Departure	0	0	0	0	0	0	0	0	0	0
Total	0	0	0	0	0	0	0	0	0	0
East Leg										
Approach	19	1	20	2	22	26	2	28	0	28
Departure	7	0	7	0	7	25	2	27	2	29
Total	26	1	27	2	29	51	4	55	2	57
West Leg										
Approach	7	0	7	2	9	25	2	27	1	28
Departure	19	1	20	1	21	26	2	28	2	30
Total	26	1	27	3	30	51	4	55	3	58
Total Approaches										
Approach	26	1	27	4	31	51	4	55	4	59
Departure	26	1	27	4	31	51	4	55	4	59
Total	52	2	54	8	62	102	8	110	8	118

Table B-4: Opening Year (2023) Base Peak Hour Volume Summary

	AM Peak Hour					PM Peak Hour				
	Exist PCE Volumes	Growth	OY Base	Project Trips	Exist With Project	Exist PCE Volumes	Growth	OY Base	Project Trips	Exist With Project
4 . Lena Road/Central Avenue										
NBL	17	1	18	5	23	15	1	16	4	20
NBT	32	2	34	0	34	46	3	49	0	49
NBR	72	4	76	0	76	45	3	48	1	49
SBL	6	0	6	0	6	9	1	10	0	10
SBT	10	1	11	0	11	33	2	35	0	35
SBR	10	1	11	0	11	9	1	10	0	10
EBL	8	0	8	0	8	10	1	11	0	11
EBT	159	10	169	0	169	174	10	184	0	184
EBR	6	0	6	5	11	17	1	18	2	20
WBL	26	2	28	1	29	22	1	23	0	23
WBT	191	11	202	0	202	269	16	285	0	285
WBR	8	0	8	0	8	6	0	6	0	6
North Leg										
Approach	26	2	28	0	28	51	4	55	0	55
Departure	48	2	50	0	50	62	4	66	0	66
Total	74	4	78	0	78	113	8	121	0	121
South Leg										
Approach	121	7	128	5	133	106	7	113	5	118
Departure	42	3	45	6	51	72	4	76	2	78
Total	163	10	173	11	184	178	11	189	7	196
East Leg										
Approach	225	13	238	1	239	297	17	314	0	314
Departure	237	14	251	0	251	228	14	242	1	243
Total	462	27	489	1	490	525	31	556	1	557
West Leg										
Approach	173	10	183	5	188	201	12	213	2	215
Departure	218	13	231	5	236	293	18	311	4	315
Total	391	23	414	10	424	494	30	524	6	530
Total Approaches										
Approach	545	32	577	11	588	655	40	695	7	702
Departure	545	32	577	11	588	655	40	695	7	702
Total	1,090	64	1,154	22	1,176	1,310	80	1,390	14	1,404

Table B-4: Opening Year (2023) Base Peak Hour Volume Summary

	AM Peak Hour					PM Peak Hour				
	Exist PCE Volumes	Growth	OY Base	Project Trips	Exist With Project	Exist PCE Volumes	Growth	OY Base	Project Trips	Exist With Project
5 . Lena Road/Driveway 3										
NBL	0	0	0	3	3	0	0	0	1	1
NBT	87	5	92	0	92	104	6	110	0	110
NBR	0	0	0	0	0	0	0	0	0	0
SBL	0	0	0	0	0	0	0	0	0	0
SBT	64	4	68	0	68	70	4	74	0	74
SBR	0	0	0	6	6	0	0	0	2	2
EBL	0	0	0	5	5	0	0	0	5	5
EBT	0	0	0	0	0	0	0	0	0	0
EBR	0	0	0	2	2	0	0	0	3	3
WBL	0	0	0	0	0	0	0	0	0	0
WBT	0	0	0	0	0	0	0	0	0	0
WBR	0	0	0	0	0	0	0	0	0	0
North Leg										
Approach	64	4	68	6	74	70	4	74	2	76
Departure	87	5	92	5	97	104	6	110	5	115
Total	151	9	160	11	171	174	10	184	7	191
South Leg										
Approach	87	5	92	3	95	104	6	110	1	111
Departure	64	4	68	2	70	70	4	74	3	77
Total	151	9	160	5	165	174	10	184	4	188
East Leg										
Approach	0	0	0	0	0	0	0	0	0	0
Departure	0	0	0	0	0	0	0	0	0	0
Total	0	0	0	0	0	0	0	0	0	0
West Leg										
Approach	0	0	0	7	7	0	0	0	8	8
Departure	0	0	0	9	9	0	0	0	3	3
Total	0	0	0	16	16	0	0	0	11	11
Total Approaches										
Approach	151	9	160	16	176	174	10	184	11	195
Departure	151	9	160	16	176	174	10	184	11	195
Total	302	18	320	32	352	348	20	368	22	390

Table B-4: Opening Year (2023) Base Peak Hour Volume Summary

	AM Peak Hour					PM Peak Hour				
	Exist PCE Volumes	Growth	OY Base	Project Trips	Exist With Project	Exist PCE Volumes	Growth	OY Base	Project Trips	Exist With Project
6 . Lena Road/Norman Road										
NBL	8	0	8	2	10	6	0	6	0	6
NBT	79	5	84	3	87	100	6	106	1	107
NBR	31	2	33	0	33	50	3	53	0	53
SBL	5	0	5	0	5	8	0	8	0	8
SBT	58	3	61	2	63	58	3	61	3	64
SBR	1	0	1	0	1	4	0	4	0	4
EBL	2	0	2	0	2	1	0	1	0	1
EBT	5	0	5	0	5	12	1	13	1	14
EBR	2	0	2	0	2	7	0	7	2	9
WBL	42	3	45	0	45	34	2	36	0	36
WBT	2	0	2	1	3	13	1	14	0	14
WBR	6	0	6	0	6	3	0	3	0	3
North Leg										
Approach	64	3	67	2	69	70	3	73	3	76
Departure	87	5	92	3	95	104	6	110	1	111
Total	151	8	159	5	164	174	9	183	4	187
South Leg										
Approach	118	7	125	5	130	156	9	165	1	166
Departure	102	6	108	2	110	99	5	104	5	109
Total	220	13	233	7	240	255	14	269	6	275
East Leg										
Approach	50	3	53	1	54	50	3	53	0	53
Departure	41	2	43	0	43	70	4	74	1	75
Total	91	5	96	1	97	120	7	127	1	128
West Leg										
Approach	9	0	9	0	9	20	1	21	3	24
Departure	11	0	11	3	14	23	1	24	0	24
Total	20	0	20	3	23	43	2	45	3	48
Total Approaches										
Approach	241	13	254	8	262	296	16	312	7	319
Departure	241	13	254	8	262	296	16	312	7	319
Total	482	26	508	16	524	592	32	624	14	638

Table B-4: Opening Year (2023) Base Peak Hour Volume Summary

	AM Peak Hour					PM Peak Hour				
	Exist PCE Volumes	Growth	OY Base	Project Trips	Exist With Project	Exist PCE Volumes	Growth	OY Base	Project Trips	Exist With Project
7 . Lena Road/Orange Show Road										
NBL	0	0	0	0	0	0	0	0	0	0
NBT	0	0	0	0	0	0	0	0	0	0
NBR	0	0	0	0	0	0	0	0	0	0
SBL	8	0	8	0	8	13	1	14	1	15
SBT	0	0	0	0	0	0	0	0	0	0
SBR	38	2	40	2	42	85	5	90	4	94
EBL	126	8	134	4	138	125	8	133	1	134
EBT	386	23	409	0	409	558	33	591	0	591
EBR	0	0	0	0	0	0	0	0	0	0
WBL	0	0	0	0	0	0	0	0	0	0
WBT	341	20	361	0	361	503	30	533	0	533
WBR	20	1	21	1	22	30	2	32	0	32
North Leg										
Approach	46	2	48	2	50	98	6	104	5	109
Departure	146	9	155	5	160	155	10	165	1	166
Total	192	11	203	7	210	253	16	269	6	275
South Leg										
Approach	0	0	0	0	0	0	0	0	0	0
Departure	0	0	0	0	0	0	0	0	0	0
Total	0	0	0	0	0	0	0	0	0	0
East Leg										
Approach	361	21	382	1	383	533	32	565	0	565
Departure	394	23	417	0	417	571	34	605	1	606
Total	755	44	799	1	800	1,104	66	1,170	1	1,171
West Leg										
Approach	512	31	543	4	547	683	41	724	1	725
Departure	379	22	401	2	403	588	35	623	4	627
Total	891	53	944	6	950	1,271	76	1,347	5	1,352
Total Approaches										
Approach	919	54	973	7	980	1,314	79	1,393	6	1,399
Departure	919	54	973	7	980	1,314	79	1,393	6	1,399
Total	1,838	108	1,946	14	1,960	2,628	158	2,786	12	2,798

Table B-5: Opening Year (2023) Base Plus Other Proposed Projects Peak Hour Volume Summary

	AM Peak Hour						PM Peak Hour							
	OY	Cumul.	GWS7	OY	OY		OY	Cumul.	GWS7	OY	OY			
	Base	Pr.	Project	Base plus	Base plus		Base	Pr.	Project	Base plus	Base plus			
	Volumes	Trips	Trips	Other Proj.	Trips	Other Pr.	plus Pr.	Volumes	Trips	Trips	Other Proj.	Trips	Other Pr.	plus Pr.
1 . Foisy Street/Driveway 1														
NBL	0	0	0	0	0	0	0	0	0	0	0	0	0	0
NBT	13	0	0	13	0	13	7	0	0	7	0	7	0	7
NBR	0	0	0	0	6	6	0	0	0	0	1	1	1	1
SBL	0	0	0	0	2	2	0	0	0	0	0	0	0	0
SBT	4	0	0	4	0	4	6	0	0	6	0	6	0	6
SBR	0	0	0	0	0	0	0	0	0	0	0	0	0	0
EBL	0	0	0	0	0	0	0	0	0	0	0	0	0	0
EBT	0	0	0	0	0	0	0	0	0	0	0	0	0	0
EBR	0	0	0	0	0	0	0	0	0	0	0	0	0	0
WBL	0	0	0	0	2	2	0	0	0	0	6	6	6	6
WBT	0	0	0	0	0	0	0	0	0	0	0	0	0	0
WBR	0	0	0	0	0	0	0	0	0	0	2	2	2	2
North Leg														
Approach	4	0	0	4	2	6	6	0	0	6	0	6	0	6
Departure	13	0	0	13	0	13	7	0	0	7	2	9	2	9
Total	17	0	0	17	2	19	13	0	0	13	2	15	2	15
South Leg														
Approach	13	0	0	13	6	19	7	0	0	7	1	8	1	8
Departure	4	0	0	4	2	6	6	0	0	6	6	12	6	12
Total	17	0	0	17	8	25	13	0	0	13	7	20	7	20
East Leg														
Approach	0	0	0	0	2	2	0	0	0	0	8	8	0	8
Departure	0	0	0	0	8	8	0	0	0	0	1	1	0	1
Total	0	0	0	0	10	10	0	0	0	0	9	9	0	9
West Leg														
Approach	0	0	0	0	0	0	0	0	0	0	0	0	0	0
Departure	0	0	0	0	0	0	0	0	0	0	0	0	0	0
Total	0	0	0	0	0	0	0	0	0	0	0	0	0	0
Total Approaches														
Approach	17	0	0	17	10	27	13	0	0	13	9	22	9	22
Departure	17	0	0	17	10	27	13	0	0	13	9	22	9	22
Total	34	0	0	34	20	54	26	0	0	26	18	44	18	44

Table B-5: Opening Year (2023) Base Plus Other Proposed Projects Peak Hour Volume Summary

	AM Peak Hour						PM Peak Hour						
	OY	Cumul.	GWS7	OY	OY		OY	Cumul.	GWS7	OY	OY		
	Base	Pr.	Project	Base plus	Base plus		Base	Pr.	Project	Base plus	Base plus		
	Volumes	Trips	Trips	Other Proj.	Trips	Other Pr.	Volumes	Trips	Trips	Other Proj.	Trips	Other Pr.	plus Pr.
2 . Foisy Street/Norman Road													
NBL	0	0	0	0	0	0	0	0	0	0	0	0	0
NBT	0	0	0	0	0	0	0	0	0	0	0	0	0
NBR	0	0	0	0	0	0	0	0	0	0	0	0	0
SBL	1	0	0	1	0	1	4	0	0	4	1	5	5
SBT	0	0	0	0	0	0	0	0	0	0	0	0	0
SBR	3	0	0	3	2	5	2	0	0	2	5	7	7
EBL	11	0	0	11	5	16	5	0	0	5	1	6	6
EBT	6	6	2	14	2	16	22	10	0	32	0	32	32
EBR	0	0	0	0	0	0	0	0	0	0	0	0	0
WBL	0	0	0	0	0	0	0	0	0	0	0	0	0
WBT	18	8	0	26	0	26	25	6	2	33	2	35	35
WBR	2	0	0	2	1	3	2	0	0	2	0	2	2
North Leg													
Approach	4	0	0	4	2	6	6	0	0	6	6	12	12
Departure	13	0	0	13	6	19	7	0	0	7	1	8	8
Total	17	0	0	17	8	25	13	0	0	13	7	20	20
South Leg													
Approach	0	0	0	0	0	0	0	0	0	0	0	0	0
Departure	0	0	0	0	0	0	0	0	0	0	0	0	0
Total	0	0	0	0	0	0	0	0	0	0	0	0	0
East Leg													
Approach	20	8	0	28	1	29	27	6	2	35	2	37	37
Departure	7	6	2	15	2	17	26	10	0	36	1	37	37
Total	27	14	2	43	3	46	53	16	2	71	3	74	74
West Leg													
Approach	17	6	2	25	7	32	27	10	0	37	1	38	38
Departure	21	8	0	29	2	31	27	6	2	35	7	42	42
Total	38	14	2	54	9	63	54	16	2	72	8	80	80
Total Approaches													
Approach	41	14	2	57	10	67	60	16	2	78	9	87	87
Departure	41	14	2	57	10	67	60	16	2	78	9	87	87
Total	82	28	4	114	20	134	120	32	4	156	18	174	174

Table B-5: Opening Year (2023) Base Plus Other Proposed Projects Peak Hour Volume Summary

	AM Peak Hour						PM Peak Hour							
	OY	Cumul.	GWS7	OY	OY		OY	Cumul.	GWS7	OY	OY			
	Base	Pr.	Project	Base plus	Base plus		Base	Pr.	Project	Base plus	Base plus			
	Volumes	Trips	Trips	Other Proj.	Trips	Other Pr.	plus Pr.	Volumes	Trips	Trips	Other Proj.	Trips	Other Pr.	plus Pr.
3 . Driveway 2/Norman Road														
NBL	0	0	0	0	0	0	0	0	0	0	0	0	0	0
NBT	0	0	0	0	0	0	0	0	0	0	0	0	0	0
NBR	0	0	0	0	0	0	0	0	0	0	0	0	0	0
SBL	0	0	0	0	0	0	0	0	0	0	0	1	1	1
SBT	0	0	0	0	0	0	0	0	0	0	0	0	0	0
SBR	0	0	0	0	0	0	0	0	0	0	0	2	2	2
EBL	0	0	0	0	2	2	0	0	0	0	0	0	0	0
EBT	7	6	2	15	0	15	27	10	0	37	1	38	38	38
EBR	0	0	0	0	0	0	0	0	0	0	0	0	0	0
WBL	0	0	0	0	0	0	0	0	0	0	0	0	0	0
WBT	20	8	0	28	1	29	28	6	2	36	0	36	36	36
WBR	0	0	0	0	1	1	0	0	0	0	0	0	0	0
North Leg														
Approach	0	0	0	0	0	0	0	0	0	0	0	3	3	3
Departure	0	0	0	0	3	3	0	0	0	0	0	0	0	0
Total	0	0	0	0	3	3	0	0	0	0	0	3	3	3
South Leg														
Approach	0	0	0	0	0	0	0	0	0	0	0	0	0	0
Departure	0	0	0	0	0	0	0	0	0	0	0	0	0	0
Total	0	0	0	0	0	0	0	0	0	0	0	0	0	0
East Leg														
Approach	20	8	0	28	2	30	28	6	2	36	0	36	36	36
Departure	7	6	2	15	0	15	27	10	0	37	2	39	39	39
Total	27	14	2	43	2	45	55	16	2	73	2	75	75	75
West Leg														
Approach	7	6	2	15	2	17	27	10	0	37	1	38	38	38
Departure	20	8	0	28	1	29	28	6	2	36	2	38	38	38
Total	27	14	2	43	3	46	55	16	2	73	3	76	76	76
Total Approaches														
Approach	27	14	2	43	4	47	55	16	2	73	4	77	77	77
Departure	27	14	2	43	4	47	55	16	2	73	4	77	77	77
Total	54	28	4	86	8	94	110	32	4	146	8	154	154	154

Table B-5: Opening Year (2023) Base Plus Other Proposed Projects Peak Hour Volume Summary

	AM Peak Hour						PM Peak Hour							
	OY	Cumul.	GWS7	OY	OY		OY	Cumul.	GWS7	OY	OY			
	Base	Pr.	Project	Base plus	Base plus		Base	Pr.	Project	Base plus	Base plus			
	Volumes	Trips	Trips	Other Proj.	Trips	Other Pr.	plus Pr.	Volumes	Trips	Trips	Other Proj.	Trips	Other Pr.	plus Pr.
4 . Lena Road/Central Avenue														
NBL	18	11	2	31	5	36	16	22	6	44	4	48		
NBT	34	5	0	39	0	39	49	6	0	55	0	55		
NBR	76	13	0	89	0	89	48	13	2	63	1	64		
SBL	6	11	0	17	0	17	10	10	0	20	0	20		
SBT	11	6	0	17	0	17	35	6	0	41	0	41		
SBR	11	2	0	13	0	13	10	3	0	13	0	13		
EBL	8	3	0	11	0	11	11	3	0	14	0	14		
EBT	169	24	0	193	0	193	184	30	0	214	0	214		
EBR	6	0	6	12	5	17	18	1	2	21	2	23		
WBL	28	11	2	41	1	42	23	12	1	36	0	36		
WBT	202	19	0	221	0	221	285	19	0	304	0	304		
WBR	8	8	0	16	0	16	6	10	0	16	0	16		
North Leg														
Approach	28	19	0	47	0	47	55	19	0	74	0	74		
Departure	50	16	0	66	0	66	66	19	0	85	0	85		
Total	78	35	0	113	0	113	121	38	0	159	0	159		
South Leg														
Approach	128	29	2	159	5	164	113	41	8	162	5	167		
Departure	45	17	8	70	6	76	76	19	3	98	2	100		
Total	173	46	10	229	11	240	189	60	11	260	7	267		
East Leg														
Approach	238	38	2	278	1	279	314	41	1	356	0	356		
Departure	251	48	0	299	0	299	242	53	2	297	1	298		
Total	489	86	2	577	1	578	556	94	3	653	1	654		
West Leg														
Approach	183	27	6	216	5	221	213	34	2	249	2	251		
Departure	231	32	2	265	5	270	311	44	6	361	4	365		
Total	414	59	8	481	10	491	524	78	8	610	6	616		
Total Approaches														
Approach	577	113	10	700	11	711	695	135	11	841	7	848		
Departure	577	113	10	700	11	711	695	135	11	841	7	848		
Total	1,154	226	20	1,400	22	1,422	1,390	270	22	1,682	14	1,696		

Table B-5: Opening Year (2023) Base Plus Other Proposed Projects Peak Hour Volume Summary

	AM Peak Hour						PM Peak Hour					
	OY Base Volumes	Cumul. Pr. Trips	GWS7 Project Trips	OY Base plus Other Proj.	OY Project Trips	OY Base plus Other Pr. plus Pr.	OY Base Volumes	Cumul. Pr. Trips	GWS7 Project Trips	OY Base plus Other Proj.	OY Project Trips	OY Base plus Other Pr. plus Pr.
5 . Lena Road/Driveway 3												
NBL	0	0	0	0	3	3	0	0	0	0	1	1
NBT	92	26	2	120	0	120	110	21	8	139	0	139
NBR	0	0	0	0	0	0	0	0	0	0	0	0
SBL	0	0	0	0	0	0	0	0	0	0	0	0
SBT	68	19	8	95	0	95	74	23	3	100	0	100
SBR	0	0	0	0	6	6	0	0	0	0	2	2
EBL	0	0	0	0	5	5	0	0	0	0	5	5
EBT	0	0	0	0	0	0	0	0	0	0	0	0
EBR	0	0	0	0	2	2	0	0	0	0	3	3
WBL	0	0	0	0	0	0	0	0	0	0	0	0
WBT	0	0	0	0	0	0	0	0	0	0	0	0
WBR	0	0	0	0	0	0	0	0	0	0	0	0
North Leg												
Approach	68	19	8	95	6	101	74	23	3	100	2	102
Departure	92	26	2	120	5	125	110	21	8	139	5	144
Total	160	45	10	215	11	226	184	44	11	239	7	246
South Leg												
Approach	92	26	2	120	3	123	110	21	8	139	1	140
Departure	68	19	8	95	2	97	74	23	3	100	3	103
Total	160	45	10	215	5	220	184	44	11	239	4	243
East Leg												
Approach	0	0	0	0	0	0	0	0	0	0	0	0
Departure	0	0	0	0	0	0	0	0	0	0	0	0
Total	0	0	0	0	0	0	0	0	0	0	0	0
West Leg												
Approach	0	0	0	0	7	7	0	0	0	0	8	8
Departure	0	0	0	0	9	9	0	0	0	0	3	3
Total	0	0	0	0	16	16	0	0	0	0	11	11
Total Approaches												
Approach	160	45	10	215	16	231	184	44	11	239	11	250
Departure	160	45	10	215	16	231	184	44	11	239	11	250
Total	320	90	20	430	32	462	368	88	22	478	22	500

Table B-5: Opening Year (2023) Base Plus Other Proposed Projects Peak Hour Volume Summary

	AM Peak Hour						PM Peak Hour					
	OY Base Volumes	Cumul. Pr. Trips	GWS7 Project Trips	OY Base plus Other Proj.	OY Project Trips	OY Base plus Other Pr. plus Pr.	OY Base Volumes	Cumul. Pr. Trips	GWS7 Project Trips	OY Base plus Other Proj.	OY Project Trips	OY Base plus Other Pr. plus Pr.
6 . Lena Road/Norman Road												
NBL	8	2	0	10	2	12	6	1	0	7	0	7
NBT	84	21	5	110	3	113	106	14	2	122	1	123
NBR	33	0	6	39	0	39	53	0	2	55	0	55
SBL	5	0	1	6	0	6	8	0	0	8	0	8
SBT	61	13	1	75	2	77	61	18	6	85	3	88
SBR	1	6	0	7	0	7	4	5	1	10	0	10
EBL	2	5	1	8	0	8	1	7	0	8	0	8
EBT	5	0	1	6	0	6	13	0	0	13	1	14
EBR	2	1	0	3	0	3	7	3	0	10	2	12
WBL	45	0	2	47	0	47	36	0	6	42	0	42
WBT	2	0	0	2	1	3	14	0	1	15	0	15
WBR	6	0	0	6	0	6	3	0	1	4	0	4
North Leg												
Approach	67	19	2	88	2	90	73	23	7	103	3	106
Departure	92	26	6	124	3	127	110	21	3	134	1	135
Total	159	45	8	212	5	217	183	44	10	237	4	241
South Leg												
Approach	125	23	11	159	5	164	165	15	4	184	1	185
Departure	108	14	3	125	2	127	104	21	12	137	5	142
Total	233	37	14	284	7	291	269	36	16	321	6	327
East Leg												
Approach	53	0	2	55	1	56	53	0	8	61	0	61
Departure	43	0	8	51	0	51	74	0	2	76	1	77
Total	96	0	10	106	1	107	127	0	10	137	1	138
West Leg												
Approach	9	6	2	17	0	17	21	10	0	31	3	34
Departure	11	8	0	19	3	22	24	6	2	32	0	32
Total	20	14	2	36	3	39	45	16	2	63	3	66
Total Approaches												
Approach	254	48	17	319	8	327	312	48	19	379	7	386
Departure	254	48	17	319	8	327	312	48	19	379	7	386
Total	508	96	34	638	16	654	624	96	38	758	14	772

Table B-5: Opening Year (2023) Base Plus Other Proposed Projects Peak Hour Volume Summary

	AM Peak Hour						PM Peak Hour							
	OY	Cumul.	GWS7	OY	OY		OY	Cumul.	GWS7	OY	OY			
	Base	Pr.	Project	Base plus	Base plus		Base	Pr.	Project	Base plus	Base plus			
	Volumes	Trips	Trips	Other Proj.	Trips	Other Pr.	plus Pr.	Volumes	Trips	Trips	Other Proj.	Trips	Other Pr.	plus Pr.
7 . Lena Road/Orange Show Road														
NBL	0	0	0	0	0	0	0	0	0	0	0	0	0	0
NBT	0	0	0	0	0	0	0	0	0	0	0	0	0	0
NBR	0	0	0	0	0	0	0	0	0	0	0	0	0	0
SBL	8	3	0	11	0	11	14	9	1	24	1	25		
SBT	0	0	0	0	0	0	0	0	0	0	0	0	0	0
SBR	40	10	3	53	2	55	90	12	10	112	4	116		
EBL	134	13	9	156	4	160	133	9	3	145	1	146		
EBT	409	14	0	423	0	423	591	15	0	606	0	606		
EBR	0	0	0	0	0	0	0	0	0	0	0	0	0	0
WBL	0	0	0	0	0	0	0	0	0	0	0	0	0	0
WBT	361	13	0	374	0	374	533	14	0	547	0	547		
WBR	21	7	1	29	1	30	32	4	1	37	0	37		
North Leg														
Approach	48	13	3	64	2	66	104	21	11	136	5	141		
Departure	155	20	10	185	5	190	165	13	4	182	1	183		
Total	203	33	13	249	7	256	269	34	15	318	6	324		
South Leg														
Approach	0	0	0	0	0	0	0	0	0	0	0	0	0	0
Departure	0	0	0	0	0	0	0	0	0	0	0	0	0	0
Total	0	0	0	0	0	0	0	0	0	0	0	0	0	0
East Leg														
Approach	382	20	1	403	1	404	565	18	1	584	0	584		
Departure	417	17	0	434	0	434	605	24	1	630	1	631		
Total	799	37	1	837	1	838	1,170	42	2	1,214	1	1,215		
West Leg														
Approach	543	27	9	579	4	583	724	24	3	751	1	752		
Departure	401	23	3	427	2	429	623	26	10	659	4	663		
Total	944	50	12	1,006	6	1,012	1,347	50	13	1,410	5	1,415		
Total Approaches														
Approach	973	60	13	1,046	7	1,053	1,393	63	15	1,471	6	1,477		
Departure	973	60	13	1,046	7	1,053	1,393	63	15	1,471	6	1,477		
Total	1,946	120	26	2,092	14	2,106	2,786	126	30	2,942	12	2,954		

**Table B-6 - Forecast Peak Hour Link Volume Worksheet
Year 2040 Link Volumes**

	Existing 2021 Volume	Existing 2021 Link Volume	Base Yr. Modeled Pk. Per. Volume	Fut. Yr. Modeled Pk. Per. Volume	Base to Future Year		2021 to 2040 Link Vol Growth ¹	2040 Link Volume
					Change	Change		

7 Lena Road/Orange Show Road

AM Peak Hour

Northbound	Left	0	Approach	0	0	0	0	0	0	0
	Through	0	Departure	0	0	0	0	0	0	0
	Right	0								
Southbound	Left	8	Approach	41	<i>Growth applied from north leg of Tippecanoe/Orange Show</i>					90
	Through	0	Departure	124						173
	Right	33								
Eastbound	Left	108	Approach	436	1,047	1,153	106	40	32	468
	Through	328	Departure	306	736	1,474	738	280	222	528
	Right	0								
Westbound	Left	0	Approach	289	736	1,474	738	280	222	511
	Through	273	Departure	336	1,047	1,153	106	40	32	368
	Right	16								

PM Peak Hour

Northbound	Left	0	Approach	0	0	0	0	0	0	0
	Through	0	Departure	0	0	0	0	0	0	0
	Right	0								
Southbound	Left	13	Approach	93	<i>Growth applied from north leg of Tippecanoe/Orange Show</i>					143
	Through	0	Departure	135						185
	Right	80								
Eastbound	Left	111	Approach	594	1,745	2,422	677	190	150	744
	Through	483	Departure	495	1,775	1,882	107	30	24	519
	Right	0								
Westbound	Left	0	Approach	439	1,775	1,882	107	30	24	463
	Through	415	Departure	496	1,745	2,422	677	190	150	646
	Right	24								

¹ Modeled base year (2016) to modeled future year (2040) conditions represent 24 years of traffic growth. Since it is 19 years from 2021 to 2040 the growth represents 0.791666666666667 % of the growth between 2016 and 2040 model years. Also the a.m. peak hour is 38% of the peak p the p.m. peak hour is 28 percent of the peak period.

**Table B-7 - Calculation of Future Directional Turn Movement Volumes
From Future Directional Link Volumes '(Based on NCHRP 255)
Year 2040 Conditions**

Approach Direction	Traffic Counts	Forecast Future Year				
		Link Volume		Forecast TM Volume		
5 Lena Road/Orange Show Road						
A.M. Peak Hour						
Northbound	Left	0	Approach	0	Left	0
	Through	0	Departure	0	Through	0
	Right	0		0	Right	0
Southbound	Left	8	Approach	90	Left	23
	Through	0	Departure	173	Through	0
	Right	33		0	Right	66
Eastbound	Left	108	Approach	468	Left	129
	Through	328	Departure	528	Through	345
	Right	0		0	Right	0
Westbound	Left	0	Approach	511	Left	0
	Through	273	Departure	368	Through	462
	Right	16		0	Right	44
<hr/>						
P.M. Peak Hour						
Northbound	Left	0	Approach	0	Left	0
	Through	0	Departure	0	Through	0
	Right	0		0	Right	0
Southbound	Left	13	Approach	143	Left	32
	Through	0	Departure	185	Through	0
	Right	80		0	Right	109
Eastbound	Left	111	Approach	744	Left	143
	Through	483	Departure	519	Through	615
	Right	0		0	Right	0
Westbound	Left	0	Approach	463	Left	0
	Through	415	Departure	646	Through	409
	Right	24			Right	42

Table B-8 - Year 2040 Peak Hour PCE Volume Summary

	AM Peak Hour						PM Peak Hour					
	Total Veh.	Truck %	Pass. Veh.	Truck PCE	Truck PCE	Total PCE Vol	Total Veh.	Truck %	Pass. Veh.	Truck PCE	Truck PCE	Total PCE Vol
7 . Lena Road/Orange Show Road												
NBL	0	0.0%	0	0	0	0	0	0.0%	0	0	0	0
NBT	0	0.0%	0	0	0	0	0	0.0%	0	0	0	0
NBR	0	0.0%	0	0	0	0	0	0.0%	0	0	0	0
SBL	23	0.0%	23	0	0	23	32	0.0%	32	0	0	32
SBT	0	0.0%	0	0	0	0	0	0.0%	0	0	0	0
SBR	66	9.1%	60	6	15	75	109	3.8%	105	4	10	115
EBL	129	10.2%	116	13	33	149	143	9.9%	129	14	35	164
EBT	345	10.7%	308	37	93	401	615	9.9%	554	61	153	707
EBR	0	0.0%	0	0	0	0	0	0.0%	0	0	0	0
WBL	0	0.0%	0	0	0	0	0	0.0%	0	0	0	0
WBT	462	16.5%	386	76	190	576	409	11.8%	361	48	120	481
WBR	44	18.8%	36	8	20	56	42	16.7%	35	7	18	53
North Leg												
Approach	89		83	6	15	98	141		137	4	10	147
Departure	173		152	21	53	205	185		164	21	53	217
Total	262		235	27	68	303	326		301	25	63	364
South Leg												
Approach	0		0	0	0	0	0		0	0	0	0
Departure	0		0	0	0	0	0		0	0	0	0
Total	0		0	0	0	0	0		0	0	0	0
East Leg												
Approach	506		422	84	210	632	451		396	55	138	534
Departure	368		331	37	93	424	647		586	61	153	739
Total	874		753	121	303	1,056	1,098		982	116	291	1,273
West Leg												
Approach	474		424	50	126	550	758		683	75	188	871
Departure	528		446	82	205	651	518		466	52	130	596
Total	1,002		870	132	331	1,201	1,276		1,149	127	318	1,467
Total Approaches												
Approach	1,069		929	140	351	1,280	1,350		1,216	134	336	1,552
Departure	1,069		929	140	351	1,280	1,350		1,216	134	336	1,552
Total	2,138		1,858	280	702	2,560	2,700		2,432	268	672	3,104

**Table B-9 - Comparison of Year 2040 to Opening Year Base plus Other Proposed Projects
plus Project Peak Hour Volumes**

	AM Peak Hour			Year 2,040 NP	PM Peak Hour			Year 2,040 NP
	2,040 NP	OY NP	Comparison		2,040 NP	OY NP	Comparison	
7 Lena Road/Orange Show Road								
NBL	0	0	0	0	0	0	0	0
NBT	0	0	0	0	0	0	0	0
NBR	0	0	0	0	0	0	0	0
SBL	23	11	12	23	32	24	8	32
SBT	0	0	0	0	0	0	0	0
SBR	75	53	22	75	115	112	3	115
EBL	149	156	-7	164	164	145	19	164
EBT	401	423	-22	444	707	606	101	707
EBR	0	0	0	0	0	0	0	0
WBL	0	0	0	0	0	0	0	0
WBT	576	374	202	576	481	547	-66	574
WBR	56	29	27	56	53	37	16	53
North Leg								
Approach	98	64	34	98	147	136	11	147
Departure	205	185	20	220	217	182	35	217
Total	303	249	54	318	364	318	46	364
South Leg								
Approach	0	0	0	0	0	0	0	0
Departure	0	0	0	0	0	0	0	0
Total	0	0	0	0	0	0	0	0
East Leg								
Approach	632	403	229	632	534	584	-50	627
Departure	424	434	-10	467	739	630	109	739
Total	1,056	837	219	1,099	1,273	1,214	59	1,366
West Leg								
Approach	550	579	-29	608	871	751	120	871
Departure	651	427	224	651	596	659	-63	689
Total	1,201	1,006	195	1,259	1,467	1,410	57	1,560
Total Approaches								
Approach	1,280	1,046	234	1,338	1,552	1,471	81	1,645
Departure	1,280	1,046	234	1,338	1,552	1,471	81	1,645
Total	2,560	2,092	468	2,676	3,104	2,942	162	3,290

Table B-10 - Year 2040 Peak Hour Volume Summary

	AM Peak Hour			PM Peak Hour		
	Year 2,040 NP	Project Trips	OY 2,040 WP	Year 2,040 NP	Project Trips	Year 2,040 WP
7 Lena Road/Orange Show Road						
NBL	0	0	0	0	0	0
NBT	0	0	0	0	0	0
NBR	0	0	0	0	0	0
SBL	23	0	23	32	1	33
SBT	0	0	0	0	0	0
SBR	75	2	77	115	4	119
EBL	164	4	168	164	1	165
EBT	444	0	444	707	0	707
EBR	0	0	0	0	0	0
WBL	0	0	0	0	0	0
WBT	576	0	576	574	0	574
WBR	56	1	57	53	0	53
North Leg						
Approach	98	2	100	147	5	152
Departure	220	5	225	217	1	218
Total	318	7	325	364	6	370
South Leg						
Approach	0	0	0	0	0	0
Departure	0	0	0	0	0	0
Total	0	0	0	0	0	0
East Leg						
Approach	632	1	633	627	0	627
Departure	467	0	467	739	1	740
Total	1,099	1	1,100	1,366	1	1,367
West Leg						
Approach	608	4	612	871	1	872
Departure	651	2	653	689	4	693
Total	1,259	6	1,265	1,560	5	1,565
Total Approaches						
Approach	1,338	7	1,345	1,645	6	1,651
Departure	1,338	7	1,345	1,645	6	1,651
Total	2,676	14	2,690	3,290	12	3,302

APPENDIX C: LEVEL OF SERVICE WORKSHEETS

HCM 6th TWSC
2: Norman Rd & Foisy Street

09/23/2021

Intersection						
Int Delay, s/veh	2.7					
Movement	EBL	EBT	WBT	WBR	SBL	SBR
Lane Configurations		↶	↷		↶	
Traffic Vol, veh/h	10	6	17	2	1	3
Future Vol, veh/h	10	6	17	2	1	3
Conflicting Peds, #/hr	0	0	0	0	0	0
Sign Control	Free	Free	Free	Free	Stop	Stop
RT Channelized	-	None	-	None	-	None
Storage Length	-	-	-	-	0	-
Veh in Median Storage, #	-	0	0	-	0	-
Grade, %	-	0	0	-	0	-
Peak Hour Factor	92	92	92	92	92	92
Heavy Vehicles, %	0	0	0	0	0	0
Mvmt Flow	11	7	18	2	1	3

Major/Minor	Major1	Major2	Minor2		
Conflicting Flow All	20	0	-	0	48 19
Stage 1	-	-	-	-	19 -
Stage 2	-	-	-	-	29 -
Critical Hdwy	4.1	-	-	-	6.4 6.2
Critical Hdwy Stg 1	-	-	-	-	5.4 -
Critical Hdwy Stg 2	-	-	-	-	5.4 -
Follow-up Hdwy	2.2	-	-	-	3.5 3.3
Pot Cap-1 Maneuver	1609	-	-	-	967 1065
Stage 1	-	-	-	-	1009 -
Stage 2	-	-	-	-	999 -
Platoon blocked, %		-	-	-	
Mov Cap-1 Maneuver	1609	-	-	-	960 1065
Mov Cap-2 Maneuver	-	-	-	-	960 -
Stage 1	-	-	-	-	1002 -
Stage 2	-	-	-	-	999 -

Approach	EB	WB	SB
HCM Control Delay, s	4.5	0	8.5
HCM LOS			A

Minor Lane/Major Mvmt	EBL	EBT	WBT	WBR	SBLn1
Capacity (veh/h)	1609	-	-	-	1037
HCM Lane V/C Ratio	0.007	-	-	-	0.004
HCM Control Delay (s)	7.3	0	-	-	8.5
HCM Lane LOS	A	A	-	-	A
HCM 95th %tile Q(veh)	0	-	-	-	0

HCM 6th Signalized Intersection Summary

4: Lena Rd & Central Ave

09/23/2021



Movement	EBL	EBT	EBR	WBL	WBT	WBR	NBL	NBT	NBR	SBL	SBT	SBR
Lane Configurations	↖	↗		↖	↗		↖	↑	↗	↖	↗	
Traffic Volume (veh/h)	8	159	6	26	191	8	17	32	72	6	10	10
Future Volume (veh/h)	8	159	6	26	191	8	17	32	72	6	10	10
Initial Q (Qb), veh	0	0	0	0	0	0	0	0	0	0	0	0
Ped-Bike Adj(A_pbT)	1.00		1.00	1.00		1.00	1.00		1.00	1.00		1.00
Parking Bus, Adj	1.00	1.00	1.00	1.00	1.00	1.00	1.00	1.00	1.00	1.00	1.00	1.00
Work Zone On Approach		No			No			No			No	
Adj Sat Flow, veh/h/ln	1700	1800	1800	1700	1800	1800	1700	1800	1800	1700	1800	1800
Adj Flow Rate, veh/h	8	162	6	27	195	8	17	33	73	6	10	10
Peak Hour Factor	0.98	0.98	0.98	0.98	0.98	0.98	0.98	0.98	0.98	0.98	0.98	0.98
Percent Heavy Veh, %	0	0	0	0	0	0	0	0	0	0	0	0
Cap, veh/h	224	420	16	253	563	23	803	970	822	722	889	764
Arrive On Green	0.00	0.12	0.12	0.04	0.17	0.17	0.02	0.54	0.54	0.00	0.51	0.51
Sat Flow, veh/h	1619	3364	124	1619	3349	137	1619	1800	1525	1619	1743	1498
Grp Volume(v), veh/h	8	82	86	27	99	104	17	33	73	6	10	10
Grp Sat Flow(s),veh/h/ln	1619	1710	1778	1619	1710	1775	1619	1800	1525	1619	1710	1530
Q Serve(g_s), s	0.1	3.5	3.6	1.1	4.1	4.1	0.4	0.7	1.9	0.1	0.2	0.3
Cycle Q Clear(g_c), s	0.1	3.5	3.6	1.1	4.1	4.1	0.4	0.7	1.9	0.1	0.2	0.3
Prop In Lane	1.00		0.07	1.00		0.08	1.00		1.00	1.00		0.98
Lane Grp Cap(c), veh/h	224	214	222	253	288	299	803	970	822	722	872	781
V/C Ratio(X)	0.04	0.38	0.39	0.11	0.34	0.35	0.02	0.03	0.09	0.01	0.01	0.01
Avail Cap(c_a), veh/h	424	363	378	386	363	377	969	970	822	923	872	781
HCM Platoon Ratio	1.00	1.00	1.00	1.00	1.00	1.00	1.00	1.00	1.00	1.00	1.00	1.00
Upstream Filter(I)	1.00	1.00	1.00	1.00	1.00	1.00	1.00	1.00	1.00	1.00	1.00	1.00
Uniform Delay (d), s/veh	31.2	32.2	32.2	28.3	29.4	29.4	8.8	8.7	8.9	9.6	9.7	9.7
Incr Delay (d2), s/veh	0.1	1.1	1.1	0.2	0.7	0.7	0.0	0.1	0.2	0.0	0.0	0.0
Initial Q Delay(d3),s/veh	0.0	0.0	0.0	0.0	0.0	0.0	0.0	0.0	0.0	0.0	0.0	0.0
%ile BackOfQ(50%),veh/ln	0.1	1.5	1.5	0.4	1.7	1.7	0.1	0.2	0.6	0.0	0.1	0.1
Unsig. Movement Delay, s/veh												
LnGrp Delay(d),s/veh	31.3	33.3	33.3	28.4	30.1	30.1	8.9	8.7	9.2	9.6	9.7	9.7
LnGrp LOS	C	C	C	C	C	C	A	A	A	A	A	A
Approach Vol, veh/h		176			230			123				26
Approach Delay, s/veh		33.2			29.9			9.0				9.7
Approach LOS		C			C			A				A
Timer - Assigned Phs	1	2	3	4	5	6	7	8				
Phs Duration (G+Y+Rc), s	5.5	49.1	9.4	16.0	7.8	46.8	6.0	19.5				
Change Period (Y+Rc), s	4.0	4.0	4.0	4.0	4.0	4.0	4.0	4.0				
Max Green Setting (Gmax), s	12.0	21.0	12.0	19.0	12.0	21.0	12.0	19.0				
Max Q Clear Time (g_c+I1), s	2.1	3.9	3.1	5.6	2.4	2.3	2.1	6.1				
Green Ext Time (p_c), s	0.0	0.3	0.0	0.6	0.0	0.0	0.0	0.8				

Intersection Summary

HCM 6th Ctrl Delay	25.4
HCM 6th LOS	C

HCM 6th AWSC
6: Lena Rd & Norman Rd

09/23/2021

Intersection	
Intersection Delay, s/veh	8
Intersection LOS	A

Movement	EBL	EBT	EBR	WBL	WBT	WBR	NBL	NBT	NBR	SBL	SBT	SBR
Lane Configurations		↕			↕		↕	↕		↕	↕	
Traffic Vol, veh/h	2	5	2	42	2	6	8	79	31	5	58	1
Future Vol, veh/h	2	5	2	42	2	6	8	79	31	5	58	1
Peak Hour Factor	0.72	0.72	0.72	0.72	0.72	0.72	0.72	0.72	0.72	0.72	0.72	0.72
Heavy Vehicles, %	0	0	0	0	0	0	0	0	0	0	0	0
Mvmt Flow	3	7	3	58	3	8	11	110	43	7	81	1
Number of Lanes	0	1	0	0	1	0	1	2	0	1	2	0

Approach	EB	WB	NB	SB
Opposing Approach	WB	EB	SB	NB
Opposing Lanes	1	1	3	3
Conflicting Approach Left	SB	NB	EB	WB
Conflicting Lanes Left	3	3	1	1
Conflicting Approach Right	NB	SB	WB	EB
Conflicting Lanes Right	3	3	1	1
HCM Control Delay	7.9	8.7	7.8	7.9
HCM LOS	A	A	A	A

Lane	NBLn1	NBLn2	NBLn3	EBLn1	WBLn1	SBLn1	SBLn2	SBLn3
Vol Left, %	100%	0%	0%	22%	84%	100%	0%	0%
Vol Thru, %	0%	100%	46%	56%	4%	0%	100%	95%
Vol Right, %	0%	0%	54%	22%	12%	0%	0%	5%
Sign Control	Stop	Stop	Stop	Stop	Stop	Stop	Stop	Stop
Traffic Vol by Lane	8	53	57	9	50	5	39	20
LT Vol	8	0	0	2	42	5	0	0
Through Vol	0	53	26	5	2	0	39	19
RT Vol	0	0	31	2	6	0	0	1
Lane Flow Rate	11	73	80	12	69	7	54	28
Geometry Grp	7	7	7	7	7	7	7	7
Degree of Util (X)	0.016	0.098	0.098	0.018	0.104	0.01	0.073	0.038
Departure Headway (Hd)	5.309	4.808	4.428	5.087	5.402	5.365	4.863	4.828
Convergence, Y/N	Yes	Yes	Yes	Yes	Yes	Yes	Yes	Yes
Cap	677	748	812	706	665	670	739	744
Service Time	3.02	2.518	2.138	2.804	3.117	3.077	2.575	2.541
HCM Lane V/C Ratio	0.016	0.098	0.099	0.017	0.104	0.01	0.073	0.038
HCM Control Delay	8.1	8	7.6	7.9	8.7	8.1	8	7.7
HCM Lane LOS	A	A	A	A	A	A	A	A
HCM 95th-tile Q	0	0.3	0.3	0.1	0.3	0	0.2	0.1

HCM 6th TWSC
7: Orange Show Rd & Lena Rd

09/23/2021

Intersection						
Int Delay, s/veh	1.8					
Movement	EBL	EBT	WBT	WBR	SBL	SBR
Lane Configurations	↘	↑↑	↑↑		↘	↘
Traffic Vol, veh/h	126	386	341	20	8	38
Future Vol, veh/h	126	386	341	20	8	38
Conflicting Peds, #/hr	0	0	0	0	0	0
Sign Control	Free	Free	Free	Free	Stop	Stop
RT Channelized	-	None	-	None	-	None
Storage Length	145	-	-	-	0	0
Veh in Median Storage, #	-	0	0	-	0	-
Grade, %	-	0	0	-	0	-
Peak Hour Factor	87	87	87	87	87	87
Heavy Vehicles, %	0	0	0	0	0	0
Mvmt Flow	145	444	392	23	9	44

Major/Minor	Major1	Major2	Minor2		
Conflicting Flow All	415	0	-	0	916 208
Stage 1	-	-	-	-	404 -
Stage 2	-	-	-	-	512 -
Critical Hdwy	4.1	-	-	-	6.8 6.9
Critical Hdwy Stg 1	-	-	-	-	5.8 -
Critical Hdwy Stg 2	-	-	-	-	5.8 -
Follow-up Hdwy	2.2	-	-	-	3.5 3.3
Pot Cap-1 Maneuver	1155	-	-	-	275 804
Stage 1	-	-	-	-	649 -
Stage 2	-	-	-	-	572 -
Platoon blocked, %		-	-	-	
Mov Cap-1 Maneuver	1155	-	-	-	240 804
Mov Cap-2 Maneuver	-	-	-	-	240 -
Stage 1	-	-	-	-	567 -
Stage 2	-	-	-	-	572 -

Approach	EB	WB	SB
HCM Control Delay, s	2.1	0	11.6
HCM LOS			B

Minor Lane/Major Mvmt	EBL	EBT	WBT	WBR	SBLn1	SBLn2
Capacity (veh/h)	1155	-	-	-	240	804
HCM Lane V/C Ratio	0.125	-	-	-	0.038	0.054
HCM Control Delay (s)	8.6	-	-	-	20.6	9.7
HCM Lane LOS	A	-	-	-	C	A
HCM 95th %tile Q(veh)	0.4	-	-	-	0.1	0.2

HCM 6th TWSC
2: Norman Rd & Foisy Street

09/23/2021

Intersection						
Int Delay, s/veh	1.5					
Movement	EBL	EBT	WBT	WBR	SBL	SBR
Lane Configurations		↶	↷		↶	↷
Traffic Vol, veh/h	5	21	24	2	4	2
Future Vol, veh/h	5	21	24	2	4	2
Conflicting Peds, #/hr	0	0	0	0	0	0
Sign Control	Free	Free	Free	Free	Stop	Stop
RT Channelized	-	None	-	None	-	None
Storage Length	-	-	-	-	0	-
Veh in Median Storage, #	-	0	0	-	0	-
Grade, %	-	0	0	-	0	-
Peak Hour Factor	92	92	92	92	92	92
Heavy Vehicles, %	0	0	0	0	0	0
Mvmt Flow	5	23	26	2	4	2























Major/Minor	Major1	Major2	Minor2		
Conflicting Flow All	28	0	-	0	60
Stage 1	-	-	-	-	27
Stage 2	-	-	-	-	33
Critical Hdwy	4.1	-	-	-	6.4
Critical Hdwy Stg 1	-	-	-	-	5.4
Critical Hdwy Stg 2	-	-	-	-	5.4
Follow-up Hdwy	2.2	-	-	-	3.5
Pot Cap-1 Maneuver	1599	-	-	-	952
Stage 1	-	-	-	-	1001
Stage 2	-	-	-	-	995
Platoon blocked, %		-	-	-	
Mov Cap-1 Maneuver	1599	-	-	-	949
Mov Cap-2 Maneuver	-	-	-	-	949
Stage 1	-	-	-	-	998
Stage 2	-	-	-	-	995

Approach	EB	WB	SB
HCM Control Delay, s	1.4	0	8.7
HCM LOS			A

Minor Lane/Major Mvmt	EBL	EBT	WBT	WBR	SBLn1
Capacity (veh/h)	1599	-	-	-	982
HCM Lane V/C Ratio	0.003	-	-	-	0.007
HCM Control Delay (s)	7.3	0	-	-	8.7
HCM Lane LOS	A	A	-	-	A
HCM 95th %tile Q(veh)	0	-	-	-	0

HCM 6th Signalized Intersection Summary
4: Lena Rd & Central Ave

09/23/2021

												
Movement	EBL	EBT	EBR	WBL	WBT	WBR	NBL	NBT	NBR	SBL	SBT	SBR
Lane Configurations												
Traffic Volume (veh/h)	10	174	17	22	269	6	15	46	45	9	33	9
Future Volume (veh/h)	10	174	17	22	269	6	15	46	45	9	33	9
Initial Q (Qb), veh	0	0	0	0	0	0	0	0	0	0	0	0
Ped-Bike Adj(A_pbT)	1.00		1.00	1.00		1.00	1.00		1.00	1.00		1.00
Parking Bus, Adj	1.00	1.00	1.00	1.00	1.00	1.00	1.00	1.00	1.00	1.00	1.00	1.00
Work Zone On Approach		No			No			No			No	
Adj Sat Flow, veh/h/ln	1700	1800	1800	1700	1800	1800	1700	1800	1800	1700	1800	1800
Adj Flow Rate, veh/h	11	200	20	25	309	7	17	53	52	10	38	10
Peak Hour Factor	0.87	0.87	0.87	0.87	0.87	0.87	0.87	0.87	0.87	0.87	0.87	0.87
Percent Heavy Veh, %	0	0	0	0	0	0	0	0	0	0	0	0
Cap, veh/h	176	393	39	225	535	12	786	956	810	733	1389	351
Arrive On Green	0.01	0.12	0.12	0.04	0.16	0.16	0.02	0.53	0.53	0.00	0.51	0.51
Sat Flow, veh/h	1619	3143	311	1619	3419	77	1619	1800	1525	1619	2703	684
Grp Volume(v), veh/h	11	108	112	25	154	162	17	53	52	10	23	25
Grp Sat Flow(s),veh/h/ln	1619	1710	1744	1619	1710	1786	1619	1800	1525	1619	1710	1677
Q Serve(g_s), s	0.5	4.7	4.8	1.0	6.7	6.7	0.4	1.1	1.3	0.2	0.5	0.6
Cycle Q Clear(g_c), s	0.5	4.7	4.8	1.0	6.7	6.7	0.4	1.1	1.3	0.2	0.5	0.6
Prop In Lane	1.00		0.18	1.00		0.04	1.00		1.00	1.00		0.41
Lane Grp Cap(c), veh/h	176	214	218	225	267	279	786	956	810	733	879	862
V/C Ratio(X)	0.06	0.50	0.51	0.11	0.58	0.58	0.02	0.06	0.06	0.01	0.03	0.03
Avail Cap(c_a), veh/h	366	363	371	365	363	380	952	956	810	928	879	862
HCM Platoon Ratio	1.00	1.00	1.00	1.00	1.00	1.00	1.00	1.00	1.00	1.00	1.00	1.00
Upstream Filter(I)	1.00	1.00	1.00	1.00	1.00	1.00	1.00	1.00	1.00	1.00	1.00	1.00
Uniform Delay (d), s/veh	30.4	32.7	32.7	28.5	31.3	31.3	8.7	9.1	9.1	9.3	9.6	9.6
Incr Delay (d2), s/veh	0.1	1.8	1.9	0.2	2.0	1.9	0.0	0.1	0.2	0.0	0.1	0.1
Initial Q Delay(d3),s/veh	0.0	0.0	0.0	0.0	0.0	0.0	0.0	0.0	0.0	0.0	0.0	0.0
%ile BackOfQ(50%),veh/ln	0.2	2.0	2.0	0.4	2.8	2.9	0.1	0.4	0.4	0.1	0.2	0.2
Unsig. Movement Delay, s/veh												
LnGrp Delay(d),s/veh	30.6	34.5	34.6	28.8	33.3	33.2	8.7	9.2	9.3	9.3	9.6	9.7
LnGrp LOS	C	C	C	C	C	C	A	A	A	A	A	A
Approach Vol, veh/h		231			341			122				58
Approach Delay, s/veh		34.4			32.9			9.1				9.6
Approach LOS		C			C			A				A
Timer - Assigned Phs	1	2	3	4	5	6	7	8				
Phs Duration (G+Y+Rc), s	6.4	48.5	9.1	16.0	7.8	47.1	6.6	18.5				
Change Period (Y+Rc), s	4.0	4.0	4.0	4.0	4.0	4.0	4.0	4.0				
Max Green Setting (Gmax), s	12.0	21.0	12.0	19.0	12.0	21.0	12.0	19.0				
Max Q Clear Time (g_c+I1), s	2.2	3.3	3.0	6.8	2.4	2.6	2.5	8.7				
Green Ext Time (p_c), s	0.0	0.3	0.0	0.8	0.0	0.1	0.0	1.1				
Intersection Summary												
HCM 6th Ctrl Delay				27.7								
HCM 6th LOS				C								

HCM 6th AWSC
6: Lena Rd & Norman Rd

09/23/2021

Intersection	
Intersection Delay, s/veh	8.1
Intersection LOS	A

Movement	EBL	EBT	EBR	WBL	WBT	WBR	NBL	NBT	NBR	SBL	SBT	SBR
Lane Configurations		↕			↕		↕	↕		↕	↕	
Traffic Vol, veh/h	1	12	7	34	13	3	6	100	50	8	58	4
Future Vol, veh/h	1	12	7	34	13	3	6	100	50	8	58	4
Peak Hour Factor	0.78	0.78	0.78	0.78	0.78	0.78	0.78	0.78	0.78	0.78	0.78	0.78
Heavy Vehicles, %	0	0	0	0	0	0	0	0	0	0	0	0
Mvmt Flow	1	15	9	44	17	4	8	128	64	10	74	5
Number of Lanes	0	1	0	0	1	0	1	2	0	1	2	0

Approach	EB	WB	NB	SB
Opposing Approach	WB	EB	SB	NB
Opposing Lanes	1	1	3	3
Conflicting Approach Left	SB	NB	EB	WB
Conflicting Lanes Left	3	3	1	1
Conflicting Approach Right	NB	SB	WB	EB
Conflicting Lanes Right	3	3	1	1
HCM Control Delay	7.9	8.8	8	7.9
HCM LOS	A	A	A	A

Lane	NBLn1	NBLn2	NBLn3	EBLn1	WBLn1	SBLn1	SBLn2	SBLn3
Vol Left, %	100%	0%	0%	5%	68%	100%	0%	0%
Vol Thru, %	0%	100%	40%	60%	26%	0%	100%	83%
Vol Right, %	0%	0%	60%	35%	6%	0%	0%	17%
Sign Control	Stop	Stop	Stop	Stop	Stop	Stop	Stop	Stop
Traffic Vol by Lane	6	67	83	20	50	8	39	23
LT Vol	6	0	0	1	34	8	0	0
Through Vol	0	67	33	12	13	0	39	19
RT Vol	0	0	50	7	3	0	0	4
Lane Flow Rate	8	85	107	26	64	10	50	30
Geometry Grp	7	7	7	7	7	7	7	7
Degree of Util (X)	0.011	0.115	0.131	0.035	0.097	0.015	0.068	0.04
Departure Headway (Hd)	5.331	4.829	4.408	4.983	5.452	5.414	4.912	4.791
Convergence, Y/N	Yes	Yes	Yes	Yes	Yes	Yes	Yes	Yes
Cap	674	745	816	720	659	663	732	750
Service Time	3.041	2.539	2.118	2.702	3.17	3.127	2.625	2.505
HCM Lane V/C Ratio	0.012	0.114	0.131	0.036	0.097	0.015	0.068	0.04
HCM Control Delay	8.1	8.2	7.8	7.9	8.8	8.2	8	7.7
HCM Lane LOS	A	A	A	A	A	A	A	A
HCM 95th-tile Q	0	0.4	0.4	0.1	0.3	0	0.2	0.1

HCM 6th TWSC
7: Orange Show Rd & Lena Rd

09/23/2021

Intersection						
Int Delay, s/veh	2					
Movement	EBL	EBT	WBT	WBR	SBL	SBR
Lane Configurations	↘	↑↑	↑↑		↘	↘
Traffic Vol, veh/h	125	558	503	30	13	85
Future Vol, veh/h	125	558	503	30	13	85
Conflicting Peds, #/hr	0	0	0	0	0	0
Sign Control	Free	Free	Free	Free	Stop	Stop
RT Channelized	-	None	-	None	-	None
Storage Length	145	-	-	-	0	0
Veh in Median Storage, #	-	0	0	-	0	-
Grade, %	-	0	0	-	0	-
Peak Hour Factor	81	81	81	81	81	81
Heavy Vehicles, %	0	0	0	0	0	0
Mvmt Flow	154	689	621	37	16	105

Major/Minor	Major1	Major2	Minor2		
Conflicting Flow All	658	0	-	0	1293 329
Stage 1	-	-	-	-	640 -
Stage 2	-	-	-	-	653 -
Critical Hdwy	4.1	-	-	-	6.8 6.9
Critical Hdwy Stg 1	-	-	-	-	5.8 -
Critical Hdwy Stg 2	-	-	-	-	5.8 -
Follow-up Hdwy	2.2	-	-	-	3.5 3.3
Pot Cap-1 Maneuver	939	-	-	-	157 673
Stage 1	-	-	-	-	493 -
Stage 2	-	-	-	-	485 -
Platoon blocked, %		-	-	-	
Mov Cap-1 Maneuver	939	-	-	-	131 673
Mov Cap-2 Maneuver	-	-	-	-	131 -
Stage 1	-	-	-	-	412 -
Stage 2	-	-	-	-	485 -

Approach	EB	WB	SB
HCM Control Delay, s	1.8	0	14.6
HCM LOS			B

Minor Lane/Major Mvmt	EBL	EBT	WBT	WBR	SBLn1	SBLn2
Capacity (veh/h)	939	-	-	-	131	673
HCM Lane V/C Ratio	0.164	-	-	-	0.123	0.156
HCM Control Delay (s)	9.6	-	-	-	36.3	11.3
HCM Lane LOS	A	-	-	-	E	B
HCM 95th %tile Q(veh)	0.6	-	-	-	0.4	0.6

HCM 6th TWSC
2: Norman Rd & Foisy Street

09/23/2021

Intersection						
Int Delay, s/veh	2.8					
Movement	EBL	EBT	WBT	WBR	SBL	SBR
Lane Configurations		↶	↷		↶	
Traffic Vol, veh/h	11	6	18	2	1	3
Future Vol, veh/h	11	6	18	2	1	3
Conflicting Peds, #/hr	0	0	0	0	0	0
Sign Control	Free	Free	Free	Free	Stop	Stop
RT Channelized	-	None	-	None	-	None
Storage Length	-	-	-	-	0	-
Veh in Median Storage, #	-	0	0	-	0	-
Grade, %	-	0	0	-	0	-
Peak Hour Factor	92	92	92	92	92	92
Heavy Vehicles, %	0	0	0	0	0	0
Mvmt Flow	12	7	20	2	1	3

Major/Minor	Major1	Major2	Minor2		
Conflicting Flow All	22	0	-	0	52 21
Stage 1	-	-	-	-	21 -
Stage 2	-	-	-	-	31 -
Critical Hdwy	4.1	-	-	-	6.4 6.2
Critical Hdwy Stg 1	-	-	-	-	5.4 -
Critical Hdwy Stg 2	-	-	-	-	5.4 -
Follow-up Hdwy	2.2	-	-	-	3.5 3.3
Pot Cap-1 Maneuver	1607	-	-	-	962 1062
Stage 1	-	-	-	-	1007 -
Stage 2	-	-	-	-	997 -
Platoon blocked, %		-	-	-	
Mov Cap-1 Maneuver	1607	-	-	-	955 1062
Mov Cap-2 Maneuver	-	-	-	-	955 -
Stage 1	-	-	-	-	1000 -
Stage 2	-	-	-	-	997 -

Approach	EB	WB	SB
HCM Control Delay, s	4.7	0	8.5
HCM LOS			A

Minor Lane/Major Mvmt	EBL	EBT	WBT	WBR	SBLn1
Capacity (veh/h)	1607	-	-	-	1033
HCM Lane V/C Ratio	0.007	-	-	-	0.004
HCM Control Delay (s)	7.3	0	-	-	8.5
HCM Lane LOS	A	A	-	-	A
HCM 95th %tile Q(veh)	0	-	-	-	0

HCM 6th Signalized Intersection Summary

4: Lena Rd & Central Ave

09/23/2021



Movement	EBL	EBT	EBR	WBL	WBT	WBR	NBL	NBT	NBR	SBL	SBT	SBR
Lane Configurations	↖	↗		↖	↗		↖	↑	↗	↖	↗	
Traffic Volume (veh/h)	8	169	6	28	202	8	18	34	76	6	11	11
Future Volume (veh/h)	8	169	6	28	202	8	18	34	76	6	11	11
Initial Q (Qb), veh	0	0	0	0	0	0	0	0	0	0	0	0
Ped-Bike Adj(A_pbT)	1.00		1.00	1.00		1.00	1.00		1.00	1.00		1.00
Parking Bus, Adj	1.00	1.00	1.00	1.00	1.00	1.00	1.00	1.00	1.00	1.00	1.00	1.00
Work Zone On Approach		No			No			No			No	
Adj Sat Flow, veh/h/ln	1700	1800	1800	1700	1800	1800	1700	1800	1800	1700	1800	1800
Adj Flow Rate, veh/h	8	172	6	29	206	8	18	35	78	6	11	11
Peak Hour Factor	0.98	0.98	0.98	0.98	0.98	0.98	0.98	0.98	0.98	0.98	0.98	0.98
Percent Heavy Veh, %	0	0	0	0	0	0	0	0	0	0	0	0
Cap, veh/h	224	421	15	255	577	22	797	963	816	711	879	755
Arrive On Green	0.00	0.12	0.12	0.05	0.17	0.17	0.02	0.54	0.54	0.00	0.50	0.50
Sat Flow, veh/h	1619	3372	117	1619	3357	130	1619	1800	1525	1619	1742	1498
Grp Volume(v), veh/h	8	87	91	29	105	109	18	35	78	6	11	11
Grp Sat Flow(s),veh/h/ln	1619	1710	1779	1619	1710	1777	1619	1800	1525	1619	1710	1530
Q Serve(g_s), s	0.1	3.7	3.8	1.2	4.3	4.4	0.4	0.7	2.0	0.1	0.3	0.3
Cycle Q Clear(g_c), s	0.1	3.7	3.8	1.2	4.3	4.4	0.4	0.7	2.0	0.1	0.3	0.3
Prop In Lane	1.00		0.07	1.00		0.07	1.00		1.00	1.00		0.98
Lane Grp Cap(c), veh/h	224	214	222	255	294	305	797	963	816	711	862	772
V/C Ratio(X)	0.04	0.41	0.41	0.11	0.36	0.36	0.02	0.04	0.10	0.01	0.01	0.01
Avail Cap(c_a), veh/h	424	363	378	382	363	378	960	963	816	912	862	772
HCM Platoon Ratio	1.00	1.00	1.00	1.00	1.00	1.00	1.00	1.00	1.00	1.00	1.00	1.00
Upstream Filter(I)	1.00	1.00	1.00	1.00	1.00	1.00	1.00	1.00	1.00	1.00	1.00	1.00
Uniform Delay (d), s/veh	31.1	32.3	32.3	28.1	29.2	29.2	9.0	8.8	9.1	9.8	9.9	9.9
Incr Delay (d2), s/veh	0.1	1.2	1.2	0.2	0.7	0.7	0.0	0.1	0.2	0.0	0.0	0.0
Initial Q Delay(d3),s/veh	0.0	0.0	0.0	0.0	0.0	0.0	0.0	0.0	0.0	0.0	0.0	0.0
%ile BackOfQ(50%),veh/ln	0.1	1.6	1.6	0.5	1.7	1.8	0.1	0.3	0.6	0.0	0.1	0.1
Unsig. Movement Delay, s/veh												
LnGrp Delay(d),s/veh	31.2	33.5	33.5	28.3	30.0	29.9	9.0	8.9	9.3	9.8	9.9	9.9
LnGrp LOS	C	C	C	C	C	C	A	A	A	A	A	A
Approach Vol, veh/h		186			243			131				28
Approach Delay, s/veh		33.4			29.7			9.2				9.9
Approach LOS		C			C			A				A
Timer - Assigned Phs	1	2	3	4	5	6	7	8				
Phs Duration (G+Y+Rc), s	5.5	48.8	9.7	16.0	8.0	46.3	6.0	19.7				
Change Period (Y+Rc), s	4.0	4.0	4.0	4.0	4.0	4.0	4.0	4.0				
Max Green Setting (Gmax), s	12.0	21.0	12.0	19.0	12.0	21.0	12.0	19.0				
Max Q Clear Time (g_c+I1), s	2.1	4.0	3.2	5.8	2.4	2.3	2.1	6.4				
Green Ext Time (p_c), s	0.0	0.3	0.0	0.6	0.0	0.0	0.0	0.8				
Intersection Summary												
HCM 6th Ctrl Delay				25.4								
HCM 6th LOS				C								

HCM 6th AWSC
6: Lena Rd & Norman Rd

09/23/2021

Intersection	
Intersection Delay, s/veh	8.1
Intersection LOS	A

Movement	EBL	EBT	EBR	WBL	WBT	WBR	NBL	NBT	NBR	SBL	SBT	SBR
Lane Configurations		↕			↕		↕	↕		↕	↕	
Traffic Vol, veh/h	2	5	2	45	2	6	8	84	33	5	61	1
Future Vol, veh/h	2	5	2	45	2	6	8	84	33	5	61	1
Peak Hour Factor	0.72	0.72	0.72	0.72	0.72	0.72	0.72	0.72	0.72	0.72	0.72	0.72
Heavy Vehicles, %	0	0	0	0	0	0	0	0	0	0	0	0
Mvmt Flow	3	7	3	63	3	8	11	117	46	7	85	1
Number of Lanes	0	1	0	0	1	0	1	2	0	1	2	0

Approach	EB	WB	NB	SB
Opposing Approach	WB	EB	SB	NB
Opposing Lanes	1	1	3	3
Conflicting Approach Left	SB	NB	EB	WB
Conflicting Lanes Left	3	3	1	1
Conflicting Approach Right	NB	SB	WB	EB
Conflicting Lanes Right	3	3	1	1
HCM Control Delay	7.9	8.8	7.9	8
HCM LOS	A	A	A	A

Lane	NBLn1	NBLn2	NBLn3	EBLn1	WBLn1	SBLn1	SBLn2	SBLn3
Vol Left, %	100%	0%	0%	22%	85%	100%	0%	0%
Vol Thru, %	0%	100%	46%	56%	4%	0%	100%	95%
Vol Right, %	0%	0%	54%	22%	11%	0%	0%	5%
Sign Control	Stop	Stop	Stop	Stop	Stop	Stop	Stop	Stop
Traffic Vol by Lane	8	56	61	9	53	5	41	21
LT Vol	8	0	0	2	45	5	0	0
Through Vol	0	56	28	5	2	0	41	20
RT Vol	0	0	33	2	6	0	0	1
Lane Flow Rate	11	78	85	12	74	7	56	30
Geometry Grp	7	7	7	7	7	7	7	7
Degree of Util (X)	0.016	0.104	0.105	0.018	0.111	0.01	0.077	0.04
Departure Headway (Hd)	5.327	4.825	4.445	5.125	5.442	5.389	4.887	4.854
Convergence, Y/N	Yes	Yes	Yes	Yes	Yes	Yes	Yes	Yes
Cap	675	746	809	700	661	667	736	740
Service Time	3.038	2.536	2.156	2.842	3.157	3.101	2.599	2.566
HCM Lane V/C Ratio	0.016	0.105	0.105	0.017	0.112	0.01	0.076	0.041
HCM Control Delay	8.1	8.1	7.7	7.9	8.8	8.2	8	7.8
HCM Lane LOS	A	A	A	A	A	A	A	A
HCM 95th-tile Q	0	0.3	0.4	0.1	0.4	0	0.2	0.1

HCM 6th TWSC
7: Orange Show Rd & Lena Rd

09/23/2021

Intersection						
Int Delay, s/veh	1.8					
Movement	EBL	EBT	WBT	WBR	SBL	SBR
Lane Configurations	↘	↑↑	↑↑		↘	↘
Traffic Vol, veh/h	134	409	361	21	8	40
Future Vol, veh/h	134	409	361	21	8	40
Conflicting Peds, #/hr	0	0	0	0	0	0
Sign Control	Free	Free	Free	Free	Stop	Stop
RT Channelized	-	None	-	None	-	None
Storage Length	145	-	-	-	0	0
Veh in Median Storage, #	-	0	0	-	0	-
Grade, %	-	0	0	-	0	-
Peak Hour Factor	87	87	87	87	87	87
Heavy Vehicles, %	0	0	0	0	0	0
Mvmt Flow	154	470	415	24	9	46

Major/Minor	Major1	Major2	Minor2		
Conflicting Flow All	439	0	-	0	970
Stage 1	-	-	-	-	427
Stage 2	-	-	-	-	543
Critical Hdwy	4.1	-	-	-	6.8
Critical Hdwy Stg 1	-	-	-	-	5.8
Critical Hdwy Stg 2	-	-	-	-	5.8
Follow-up Hdwy	2.2	-	-	-	3.5
Pot Cap-1 Maneuver	1132	-	-	-	254
Stage 1	-	-	-	-	632
Stage 2	-	-	-	-	552
Platoon blocked, %		-	-	-	
Mov Cap-1 Maneuver	1132	-	-	-	219
Mov Cap-2 Maneuver	-	-	-	-	219
Stage 1	-	-	-	-	546
Stage 2	-	-	-	-	552

Approach	EB	WB	SB
HCM Control Delay, s	2.1	0	11.9
HCM LOS			B

Minor Lane/Major Mvmt	EBL	EBT	WBT	WBR	SBLn1	SBLn2
Capacity (veh/h)	1132	-	-	-	219	790
HCM Lane V/C Ratio	0.136	-	-	-	0.042	0.058
HCM Control Delay (s)	8.7	-	-	-	22.2	9.8
HCM Lane LOS	A	-	-	-	C	A
HCM 95th %tile Q(veh)	0.5	-	-	-	0.1	0.2

HCM 6th TWSC
2: Norman Rd & Foisy Street

09/23/2021

Intersection						
Int Delay, s/veh	1.5					
Movement	EBL	EBT	WBT	WBR	SBL	SBR
Lane Configurations		↶	↷		↶	
Traffic Vol, veh/h	5	22	25	2	4	2
Future Vol, veh/h	5	22	25	2	4	2
Conflicting Peds, #/hr	0	0	0	0	0	0
Sign Control	Free	Free	Free	Free	Stop	Stop
RT Channelized	-	None	-	None	-	None
Storage Length	-	-	-	-	0	-
Veh in Median Storage, #	-	0	0	-	0	-
Grade, %	-	0	0	-	0	-
Peak Hour Factor	92	92	92	92	92	92
Heavy Vehicles, %	0	0	0	0	0	0
Mvmt Flow	5	24	27	2	4	2

Major/Minor	Major1	Major2	Minor2		
Conflicting Flow All	29	0	-	0	62 28
Stage 1	-	-	-	-	28 -
Stage 2	-	-	-	-	34 -
Critical Hdwy	4.1	-	-	-	6.4 6.2
Critical Hdwy Stg 1	-	-	-	-	5.4 -
Critical Hdwy Stg 2	-	-	-	-	5.4 -
Follow-up Hdwy	2.2	-	-	-	3.5 3.3
Pot Cap-1 Maneuver	1597	-	-	-	949 1053
Stage 1	-	-	-	-	1000 -
Stage 2	-	-	-	-	994 -
Platoon blocked, %		-	-	-	
Mov Cap-1 Maneuver	1597	-	-	-	946 1053
Mov Cap-2 Maneuver	-	-	-	-	946 -
Stage 1	-	-	-	-	997 -
Stage 2	-	-	-	-	994 -























Approach	EB	WB	SB
HCM Control Delay, s	1.3	0	8.7
HCM LOS			A

Minor Lane/Major Mvmt	EBL	EBT	WBT	WBR	SBLn1
Capacity (veh/h)	1597	-	-	-	979
HCM Lane V/C Ratio	0.003	-	-	-	0.007
HCM Control Delay (s)	7.3	0	-	-	8.7
HCM Lane LOS	A	A	-	-	A
HCM 95th %tile Q(veh)	0	-	-	-	0

HCM 6th Signalized Intersection Summary

4: Lena Rd & Central Ave

09/23/2021

												
Movement	EBL	EBT	EBR	WBL	WBT	WBR	NBL	NBT	NBR	SBL	SBT	SBR
Lane Configurations												
Traffic Volume (veh/h)	11	184	18	23	285	6	16	49	48	10	35	10
Future Volume (veh/h)	11	184	18	23	285	6	16	49	48	10	35	10
Initial Q (Qb), veh	0	0	0	0	0	0	0	0	0	0	0	0
Ped-Bike Adj(A_pbT)	1.00		1.00	1.00		1.00	1.00		1.00	1.00		1.00
Parking Bus, Adj	1.00	1.00	1.00	1.00	1.00	1.00	1.00	1.00	1.00	1.00	1.00	1.00
Work Zone On Approach		No			No			No			No	
Adj Sat Flow, veh/h/ln	1700	1800	1800	1700	1800	1800	1700	1800	1800	1700	1800	1800
Adj Flow Rate, veh/h	13	211	21	26	328	7	18	56	55	11	40	11
Peak Hour Factor	0.87	0.87	0.87	0.87	0.87	0.87	0.87	0.87	0.87	0.87	0.87	0.87
Percent Heavy Veh, %	0	0	0	0	0	0	0	0	0	0	0	0
Cap, veh/h	174	393	39	224	525	11	782	948	803	729	1364	360
Arrive On Green	0.01	0.12	0.12	0.04	0.15	0.15	0.02	0.53	0.53	0.01	0.51	0.51
Sat Flow, veh/h	1619	3144	310	1619	3424	73	1619	1800	1525	1619	2677	706
Grp Volume(v), veh/h	13	114	118	26	164	171	18	56	55	11	25	26
Grp Sat Flow(s),veh/h/ln	1619	1710	1744	1619	1710	1787	1619	1800	1525	1619	1710	1673
Q Serve(g_s), s	0.6	5.0	5.1	1.1	7.2	7.2	0.4	1.2	1.4	0.3	0.6	0.6
Cycle Q Clear(g_c), s	0.6	5.0	5.1	1.1	7.2	7.2	0.4	1.2	1.4	0.3	0.6	0.6
Prop In Lane	1.00		0.18	1.00		0.04	1.00		1.00	1.00		0.42
Lane Grp Cap(c), veh/h	174	214	218	224	262	274	782	948	803	729	872	853
V/C Ratio(X)	0.07	0.53	0.54	0.12	0.62	0.63	0.02	0.06	0.07	0.02	0.03	0.03
Avail Cap(c_a), veh/h	356	363	371	360	363	380	944	948	803	919	872	853
HCM Platoon Ratio	1.00	1.00	1.00	1.00	1.00	1.00	1.00	1.00	1.00	1.00	1.00	1.00
Upstream Filter(I)	1.00	1.00	1.00	1.00	1.00	1.00	1.00	1.00	1.00	1.00	1.00	1.00
Uniform Delay (d), s/veh	30.1	32.8	32.9	28.5	31.7	31.7	8.8	9.3	9.3	9.4	9.8	9.8
Incr Delay (d2), s/veh	0.2	2.1	2.1	0.2	2.4	2.3	0.0	0.1	0.2	0.0	0.1	0.1
Initial Q Delay(d3),s/veh	0.0	0.0	0.0	0.0	0.0	0.0	0.0	0.0	0.0	0.0	0.0	0.0
%ile BackOfQ(50%),veh/ln	0.2	2.1	2.2	0.4	3.0	3.1	0.1	0.4	0.4	0.1	0.2	0.2
Unsig. Movement Delay, s/veh												
LnGrp Delay(d),s/veh	30.3	34.9	34.9	28.7	34.1	34.1	8.8	9.4	9.5	9.4	9.8	9.8
LnGrp LOS	C	C	C	C	C	C	A	A	A	A	A	A
Approach Vol, veh/h		245			361			129			62	
Approach Delay, s/veh		34.7			33.7			9.3			9.7	
Approach LOS		C			C			A			A	
Timer - Assigned Phs	1	2	3	4	5	6	7	8				
Phs Duration (G+Y+Rc), s	6.6	48.1	9.3	16.0	8.0	46.8	7.0	18.3				
Change Period (Y+Rc), s	4.0	4.0	4.0	4.0	4.0	4.0	4.0	4.0				
Max Green Setting (Gmax), s	12.0	21.0	12.0	19.0	12.0	21.0	12.0	19.0				
Max Q Clear Time (g_c+I1), s	2.3	3.4	3.1	7.1	2.4	2.6	2.6	9.2				
Green Ext Time (p_c), s	0.0	0.3	0.0	0.9	0.0	0.1	0.0	1.2				
Intersection Summary												
HCM 6th Ctrl Delay				28.2								
HCM 6th LOS				C								

HCM 6th AWSC
6: Lena Rd & Norman Rd

09/23/2021

Intersection	
Intersection Delay, s/veh	8.1
Intersection LOS	A

Movement	EBL	EBT	EBR	WBL	WBT	WBR	NBL	NBT	NBR	SBL	SBT	SBR
Lane Configurations		↕			↕		↕	↕		↕	↕	
Traffic Vol, veh/h	1	13	7	36	14	3	6	106	53	8	61	4
Future Vol, veh/h	1	13	7	36	14	3	6	106	53	8	61	4
Peak Hour Factor	0.78	0.78	0.78	0.78	0.78	0.78	0.78	0.78	0.78	0.78	0.78	0.78
Heavy Vehicles, %	0	0	0	0	0	0	0	0	0	0	0	0
Mvmt Flow	1	17	9	46	18	4	8	136	68	10	78	5
Number of Lanes	0	1	0	0	1	0	1	2	0	1	2	0

Approach	EB	WB	NB	SB
Opposing Approach	WB	EB	SB	NB
Opposing Lanes	1	1	3	3
Conflicting Approach Left	SB	NB	EB	WB
Conflicting Lanes Left	3	3	1	1
Conflicting Approach Right	NB	SB	WB	EB
Conflicting Lanes Right	3	3	1	1
HCM Control Delay	8	8.8	8	8
HCM LOS	A	A	A	A

Lane	NBLn1	NBLn2	NBLn3	EBLn1	WBLn1	SBLn1	SBLn2	SBLn3
Vol Left, %	100%	0%	0%	5%	68%	100%	0%	0%
Vol Thru, %	0%	100%	40%	62%	26%	0%	100%	84%
Vol Right, %	0%	0%	60%	33%	6%	0%	0%	16%
Sign Control	Stop	Stop	Stop	Stop	Stop	Stop	Stop	Stop
Traffic Vol by Lane	6	71	88	21	53	8	41	24
LT Vol	6	0	0	1	36	8	0	0
Through Vol	0	71	35	13	14	0	41	20
RT Vol	0	0	53	7	3	0	0	4
Lane Flow Rate	8	91	113	27	68	10	52	31
Geometry Grp	7	7	7	7	7	7	7	7
Degree of Util (X)	0.011	0.122	0.139	0.038	0.104	0.016	0.072	0.042
Departure Headway (Hd)	5.35	4.848	4.427	5.03	5.487	5.441	4.939	4.823
Convergence, Y/N	Yes	Yes	Yes	Yes	Yes	Yes	Yes	Yes
Cap	671	741	812	713	654	660	727	744
Service Time	3.066	2.564	2.143	2.755	3.21	3.159	2.657	2.541
HCM Lane V/C Ratio	0.012	0.123	0.139	0.038	0.104	0.015	0.072	0.042
HCM Control Delay	8.1	8.2	7.9	8	8.8	8.2	8	7.8
HCM Lane LOS	A	A	A	A	A	A	A	A
HCM 95th-tile Q	0	0.4	0.5	0.1	0.3	0	0.2	0.1

HCM 6th TWSC
7: Orange Show Rd & Lena Rd

09/23/2021

Intersection						
Int Delay, s/veh	2.1					
Movement	EBL	EBT	WBT	WBR	SBL	SBR
Lane Configurations	↘	↑↑	↑↑		↘	↗
Traffic Vol, veh/h	133	591	533	32	14	90
Future Vol, veh/h	133	591	533	32	14	90
Conflicting Peds, #/hr	0	0	0	0	0	0
Sign Control	Free	Free	Free	Free	Stop	Stop
RT Channelized	-	None	-	None	-	None
Storage Length	145	-	-	-	0	0
Veh in Median Storage, #	-	0	0	-	0	-
Grade, %	-	0	0	-	0	-
Peak Hour Factor	81	81	81	81	81	81
Heavy Vehicles, %	0	0	0	0	0	0
Mvmt Flow	164	730	658	40	17	111

Major/Minor	Major1	Major2	Minor2		
Conflicting Flow All	698	0	-	0	1371 349
Stage 1	-	-	-	-	678 -
Stage 2	-	-	-	-	693 -
Critical Hdwy	4.1	-	-	-	6.8 6.9
Critical Hdwy Stg 1	-	-	-	-	5.8 -
Critical Hdwy Stg 2	-	-	-	-	5.8 -
Follow-up Hdwy	2.2	-	-	-	3.5 3.3
Pot Cap-1 Maneuver	908	-	-	-	140 653
Stage 1	-	-	-	-	471 -
Stage 2	-	-	-	-	463 -
Platoon blocked, %		-	-	-	
Mov Cap-1 Maneuver	908	-	-	-	115 653
Mov Cap-2 Maneuver	-	-	-	-	115 -
Stage 1	-	-	-	-	386 -
Stage 2	-	-	-	-	463 -

Approach	EB	WB	SB
HCM Control Delay, s	1.8	0	15.7
HCM LOS			C

Minor Lane/Major Mvmt	EBL	EBT	WBT	WBR	SBLn1	SBLn2
Capacity (veh/h)	908	-	-	-	115	653
HCM Lane V/C Ratio	0.181	-	-	-	0.15	0.17
HCM Control Delay (s)	9.8	-	-	-	41.8	11.6
HCM Lane LOS	A	-	-	-	E	B
HCM 95th %tile Q(veh)	0.7	-	-	-	0.5	0.6

HCM 6th TWSC
2: Norman Rd & Foisy Street

09/23/2021

Intersection						
Int Delay, s/veh	2					
Movement	EBL	EBT	WBT	WBR	SBL	SBR
Lane Configurations		↕	↕		↕	
Traffic Vol, veh/h	11	14	26	2	1	3
Future Vol, veh/h	11	14	26	2	1	3
Conflicting Peds, #/hr	0	0	0	0	0	0
Sign Control	Free	Free	Free	Free	Stop	Stop
RT Channelized	-	None	-	None	-	None
Storage Length	-	-	-	-	0	-
Veh in Median Storage, #	-	0	0	-	0	-
Grade, %	-	0	0	-	0	-
Peak Hour Factor	92	92	92	92	92	92
Heavy Vehicles, %	0	0	0	0	0	0
Mvmt Flow	12	15	28	2	1	3

Major/Minor	Major1	Major2	Minor2		
Conflicting Flow All	30	0	-	0	68 29
Stage 1	-	-	-	-	29 -
Stage 2	-	-	-	-	39 -
Critical Hdwy	4.1	-	-	-	6.4 6.2
Critical Hdwy Stg 1	-	-	-	-	5.4 -
Critical Hdwy Stg 2	-	-	-	-	5.4 -
Follow-up Hdwy	2.2	-	-	-	3.5 3.3
Pot Cap-1 Maneuver	1596	-	-	-	942 1052
Stage 1	-	-	-	-	999 -
Stage 2	-	-	-	-	989 -
Platoon blocked, %		-	-	-	
Mov Cap-1 Maneuver	1596	-	-	-	934 1052
Mov Cap-2 Maneuver	-	-	-	-	934 -
Stage 1	-	-	-	-	991 -
Stage 2	-	-	-	-	989 -























Approach	EB	WB	SB
HCM Control Delay, s	3.2	0	8.5
HCM LOS			A

Minor Lane/Major Mvmt	EBL	EBT	WBT	WBR	SBLn1
Capacity (veh/h)	1596	-	-	-	1020
HCM Lane V/C Ratio	0.007	-	-	-	0.004
HCM Control Delay (s)	7.3	0	-	-	8.5
HCM Lane LOS	A	A	-	-	A
HCM 95th %tile Q(veh)	0	-	-	-	0

HCM 6th Signalized Intersection Summary

4: Lena Rd & Central Ave

09/23/2021

												
Movement	EBL	EBT	EBR	WBL	WBT	WBR	NBL	NBT	NBR	SBL	SBT	SBR
Lane Configurations												
Traffic Volume (veh/h)	11	193	17	42	221	16	31	39	89	17	17	13
Future Volume (veh/h)	11	193	17	42	221	16	31	39	89	17	17	13
Initial Q (Qb), veh	0	0	0	0	0	0	0	0	0	0	0	0
Ped-Bike Adj(A_pbT)	1.00		1.00	1.00		1.00	1.00		1.00	1.00		1.00
Parking Bus, Adj	1.00	1.00	1.00	1.00	1.00	1.00	1.00	1.00	1.00	1.00	1.00	1.00
Work Zone On Approach		No			No			No			No	
Adj Sat Flow, veh/h/ln	1700	1800	1800	1700	1800	1800	1700	1800	1800	1700	1800	1800
Adj Flow Rate, veh/h	11	197	17	43	226	16	32	40	91	17	17	13
Peak Hour Factor	0.98	0.98	0.98	0.98	0.98	0.98	0.98	0.98	0.98	0.98	0.98	0.98
Percent Heavy Veh, %	0	0	0	0	0	0	0	0	0	0	0	0
Cap, veh/h	237	399	34	274	599	42	713	874	741	281	462	315
Arrive On Green	0.01	0.12	0.12	0.07	0.18	0.18	0.27	0.49	0.49	0.02	0.24	0.24
Sat Flow, veh/h	1619	3188	273	1619	3241	228	1619	1800	1525	1619	1946	1325
Grp Volume(v), veh/h	11	105	109	43	119	123	32	40	91	17	15	15
Grp Sat Flow(s),veh/h/ln	1619	1710	1751	1619	1710	1759	1619	1800	1525	1619	1710	1561
Q Serve(g_s), s	0.5	4.6	4.7	1.7	4.9	4.9	0.0	0.9	2.6	0.7	0.5	0.6
Cycle Q Clear(g_c), s	0.5	4.6	4.7	1.7	4.9	4.9	0.0	0.9	2.6	0.7	0.5	0.6
Prop In Lane	1.00		0.16	1.00		0.13	1.00		1.00	1.00		0.85
Lane Grp Cap(c), veh/h	237	214	219	274	316	325	713	874	741	281	406	371
V/C Ratio(X)	0.05	0.49	0.50	0.16	0.38	0.38	0.04	0.05	0.12	0.06	0.04	0.04
Avail Cap(c_a), veh/h	427	363	372	367	363	374	713	874	741	448	406	371
HCM Platoon Ratio	1.00	1.00	1.00	1.00	1.00	1.00	1.00	1.00	1.00	1.00	1.00	1.00
Upstream Filter(I)	1.00	1.00	1.00	1.00	1.00	1.00	1.00	1.00	1.00	1.00	1.00	1.00
Uniform Delay (d), s/veh	30.3	32.6	32.7	25.5	28.6	28.6	14.2	10.8	11.3	26.7	23.5	23.5
Incr Delay (d2), s/veh	0.1	1.7	1.8	0.3	0.7	0.7	0.0	0.1	0.3	0.1	0.2	0.2
Initial Q Delay(d3),s/veh	0.0	0.0	0.0	0.0	0.0	0.0	0.0	0.0	0.0	0.0	0.0	0.0
%ile BackOfQ(50%),veh/ln	0.2	1.9	2.0	0.6	1.9	2.0	0.3	0.4	0.9	0.3	0.2	0.2
Unsig. Movement Delay, s/veh												
LnGrp Delay(d),s/veh	30.4	34.4	34.4	25.7	29.3	29.3	14.3	10.9	11.6	26.8	23.6	23.7
LnGrp LOS	C	C	C	C	C	C	B	B	B	C	C	C
Approach Vol, veh/h		225			285			163			47	
Approach Delay, s/veh		34.2			28.8			12.0			24.8	
Approach LOS		C			C			B			C	
Timer - Assigned Phs	1	2	3	4	5	6	7	8				
Phs Duration (G+Y+Rc), s	7.8	44.8	11.4	16.0	27.6	25.0	6.6	20.8				
Change Period (Y+Rc), s	4.0	4.0	4.0	4.0	4.0	4.0	4.0	4.0				
Max Green Setting (Gmax), s	12.0	21.0	12.0	19.0	12.0	21.0	12.0	19.0				
Max Q Clear Time (g_c+I1), s	2.7	4.6	3.7	6.7	2.0	2.6	2.5	6.9				
Green Ext Time (p_c), s	0.0	0.4	0.0	0.8	0.0	0.1	0.0	0.9				
Intersection Summary												
HCM 6th Ctrl Delay			26.4									
HCM 6th LOS			C									

HCM 6th AWSC
6: Lena Rd & Norman Rd

09/23/2021

Intersection	
Intersection Delay, s/veh	8.3
Intersection LOS	A

Movement	EBL	EBT	EBR	WBL	WBT	WBR	NBL	NBT	NBR	SBL	SBT	SBR
Lane Configurations		↕			↕		↕	↕		↕	↕	
Traffic Vol, veh/h	8	6	3	47	2	6	10	110	39	6	75	7
Future Vol, veh/h	8	6	3	47	2	6	10	110	39	6	75	7
Peak Hour Factor	0.72	0.72	0.72	0.72	0.72	0.72	0.72	0.72	0.72	0.72	0.72	0.72
Heavy Vehicles, %	0	0	0	0	0	0	0	0	0	0	0	0
Mvmt Flow	11	8	4	65	3	8	14	153	54	8	104	10
Number of Lanes	0	1	0	0	1	0	1	2	0	1	2	0

Approach	EB	WB	NB	SB
Opposing Approach	WB	EB	SB	NB
Opposing Lanes	1	1	3	3
Conflicting Approach Left	SB	NB	EB	WB
Conflicting Lanes Left	3	3	1	1
Conflicting Approach Right	NB	SB	WB	EB
Conflicting Lanes Right	3	3	1	1
HCM Control Delay	8.4	9.1	8.1	8.1
HCM LOS	A	A	A	A

Lane	NBLn1	NBLn2	NBLn3	EBLn1	WBLn1	SBLn1	SBLn2	SBLn3
Vol Left, %	100%	0%	0%	47%	85%	100%	0%	0%
Vol Thru, %	0%	100%	48%	35%	4%	0%	100%	78%
Vol Right, %	0%	0%	52%	18%	11%	0%	0%	22%
Sign Control	Stop	Stop	Stop	Stop	Stop	Stop	Stop	Stop
Traffic Vol by Lane	10	73	76	17	55	6	50	32
LT Vol	10	0	0	8	47	6	0	0
Through Vol	0	73	37	6	2	0	50	25
RT Vol	0	0	39	3	6	0	0	7
Lane Flow Rate	14	102	105	24	76	8	69	44
Geometry Grp	7	7	7	7	7	7	7	7
Degree of Util (X)	0.021	0.139	0.132	0.036	0.119	0.013	0.096	0.06
Departure Headway (Hd)	5.399	4.897	4.535	5.452	5.622	5.479	4.977	4.823
Convergence, Y/N	Yes	Yes	Yes	Yes	Yes	Yes	Yes	Yes
Cap	665	733	792	657	638	655	722	744
Service Time	3.119	2.617	2.254	3.185	3.352	3.201	2.699	2.545
HCM Lane V/C Ratio	0.021	0.139	0.133	0.037	0.119	0.012	0.096	0.059
HCM Control Delay	8.2	8.4	7.9	8.4	9.1	8.3	8.2	7.9
HCM Lane LOS	A	A	A	A	A	A	A	A
HCM 95th-tile Q	0.1	0.5	0.5	0.1	0.4	0	0.3	0.2

HCM 6th TWSC
7: Orange Show Rd & Lena Rd

09/23/2021

Intersection						
Int Delay, s/veh	2.1					
Movement	EBL	EBT	WBT	WBR	SBL	SBR
Lane Configurations	↘	↑↑	↑↑		↘	↘
Traffic Vol, veh/h	156	423	374	29	11	53
Future Vol, veh/h	156	423	374	29	11	53
Conflicting Peds, #/hr	0	0	0	0	0	0
Sign Control	Free	Free	Free	Free	Stop	Stop
RT Channelized	-	None	-	None	-	None
Storage Length	145	-	-	-	0	0
Veh in Median Storage, #	-	0	0	-	0	-
Grade, %	-	0	0	-	0	-
Peak Hour Factor	87	87	87	87	87	87
Heavy Vehicles, %	0	0	0	0	0	0
Mvmt Flow	179	486	430	33	13	61

Major/Minor	Major1	Major2	Minor2		
Conflicting Flow All	463	0	0	1048	232
Stage 1	-	-	-	447	-
Stage 2	-	-	-	601	-
Critical Hdwy	4.1	-	-	6.8	6.9
Critical Hdwy Stg 1	-	-	-	5.8	-
Critical Hdwy Stg 2	-	-	-	5.8	-
Follow-up Hdwy	2.2	-	-	3.5	3.3
Pot Cap-1 Maneuver	1109	-	-	227	776
Stage 1	-	-	-	617	-
Stage 2	-	-	-	516	-
Platoon blocked, %	-	-	-	-	-
Mov Cap-1 Maneuver	1109	-	-	190	776
Mov Cap-2 Maneuver	-	-	-	190	-
Stage 1	-	-	-	518	-
Stage 2	-	-	-	516	-

Approach	EB	WB	SB
HCM Control Delay, s	2.4	0	12.6
HCM LOS			B

Minor Lane/Major Mvmt	EBL	EBT	WBT	WBR	SBLn1	SBLn2
Capacity (veh/h)	1109	-	-	-	190	776
HCM Lane V/C Ratio	0.162	-	-	-	0.067	0.079
HCM Control Delay (s)	8.9	-	-	-	25.3	10
HCM Lane LOS	A	-	-	-	D	B
HCM 95th %tile Q(veh)	0.6	-	-	-	0.2	0.3

HCM 6th TWSC
1: Foisy Street & Driveway 1

09/23/2021

Intersection						
Int Delay, s/veh	0					
Movement	WBL	WBR	NBT	NBR	SBL	SBT
Lane Configurations						
Traffic Vol, veh/h	0	0	0	0	0	0
Future Vol, veh/h	0	0	0	0	0	0
Conflicting Peds, #/hr	0	0	0	0	0	0
Sign Control	Stop	Stop	Free	Free	Free	Free
RT Channelized	-	None	-	None	-	None
Storage Length	0	-	-	-	-	-
Veh in Median Storage, #	0	-	0	-	-	0
Grade, %	0	-	0	-	-	0
Peak Hour Factor	92	92	92	92	92	92
Heavy Vehicles, %	0	0	0	0	0	0
Mvmt Flow	0	0	0	0	0	0

Major/Minor	Minor1	Major1	Major2			
Conflicting Flow All	1	0	0	0	0	0
Stage 1	0	-	-	-	-	-
Stage 2	1	-	-	-	-	-
Critical Hdwy	6.4	6.2	-	-	4.1	-
Critical Hdwy Stg 1	5.4	-	-	-	-	-
Critical Hdwy Stg 2	5.4	-	-	-	-	-
Follow-up Hdwy	3.5	3.3	-	-	2.2	-
Pot Cap-1 Maneuver	1027	-	-	-	-	-
Stage 1	-	-	-	-	-	-
Stage 2	1028	-	-	-	-	-
Platoon blocked, %						
Mov Cap-1 Maneuver	1027	-	-	-	-	-
Mov Cap-2 Maneuver	1027	-	-	-	-	-
Stage 1	-	-	-	-	-	-
Stage 2	1028	-	-	-	-	-

Approach	WB	NB	SB
HCM Control Delay, s	0	0	0
HCM LOS	A		

Minor Lane/Major Mvmt	NBT	NBRWBLn1	SBL	SBT
Capacity (veh/h)	-	-	-	-
HCM Lane V/C Ratio	-	-	-	-
HCM Control Delay (s)	-	-	0	0
HCM Lane LOS	-	-	A	A
HCM 95th %tile Q(veh)	-	-	-	-

HCM 6th TWSC
2: Norman Rd & Foisy Street

09/23/2021

Intersection						
Int Delay, s/veh	1.2					
Movement	EBL	EBT	WBT	WBR	SBL	SBR
Lane Configurations		↕	↕		↕	
Traffic Vol, veh/h	5	32	33	2	4	2
Future Vol, veh/h	5	32	33	2	4	2
Conflicting Peds, #/hr	0	0	0	0	0	0
Sign Control	Free	Free	Free	Free	Stop	Stop
RT Channelized	-	None	-	None	-	None
Storage Length	-	-	-	-	0	-
Veh in Median Storage, #	-	0	0	-	0	-
Grade, %	-	0	0	-	0	-
Peak Hour Factor	92	92	92	92	92	92
Heavy Vehicles, %	0	0	0	0	0	0
Mvmt Flow	5	35	36	2	4	2

Major/Minor	Major1	Major2	Minor2		
Conflicting Flow All	38	0	-	0	82 37
Stage 1	-	-	-	-	37 -
Stage 2	-	-	-	-	45 -
Critical Hdwy	4.1	-	-	-	6.4 6.2
Critical Hdwy Stg 1	-	-	-	-	5.4 -
Critical Hdwy Stg 2	-	-	-	-	5.4 -
Follow-up Hdwy	2.2	-	-	-	3.5 3.3
Pot Cap-1 Maneuver	1585	-	-	-	925 1041
Stage 1	-	-	-	-	991 -
Stage 2	-	-	-	-	983 -
Platoon blocked, %		-	-	-	
Mov Cap-1 Maneuver	1585	-	-	-	922 1041
Mov Cap-2 Maneuver	-	-	-	-	922 -
Stage 1	-	-	-	-	988 -
Stage 2	-	-	-	-	983 -

Approach	EB	WB	SB
HCM Control Delay, s	1	0	8.8
HCM LOS			A

Minor Lane/Major Mvmt	EBL	EBT	WBT	WBR	SBLn1
Capacity (veh/h)	1585	-	-	-	959
HCM Lane V/C Ratio	0.003	-	-	-	0.007
HCM Control Delay (s)	7.3	0	-	-	8.8
HCM Lane LOS	A	A	-	-	A
HCM 95th %tile Q(veh)	0	-	-	-	0

HCM 6th TWSC
3: Norman Rd & Driveway 2

09/23/2021

Intersection						
Int Delay, s/veh	0					
Movement	EBL	EBT	WBT	WBR	SBL	SBR
Lane Configurations		↶	↷		↶	
Traffic Vol, veh/h	0	0	0	0	0	0
Future Vol, veh/h	0	0	0	0	0	0
Conflicting Peds, #/hr	0	0	0	0	0	0
Sign Control	Free	Free	Free	Free	Stop	Stop
RT Channelized	-	None	-	None	-	None
Storage Length	-	-	-	-	0	-
Veh in Median Storage, #	-	0	0	-	0	-
Grade, %	-	0	0	-	0	-
Peak Hour Factor	92	92	92	92	92	92
Heavy Vehicles, %	0	0	0	0	0	0
Mvmt Flow	0	0	0	0	0	0

Major/Minor	Major1	Major2	Minor2		
Conflicting Flow All	1	0	-	0	1 1
Stage 1	-	-	-	-	1 -
Stage 2	-	-	-	-	0 -
Critical Hdwy	4.1	-	-	-	6.4 6.2
Critical Hdwy Stg 1	-	-	-	-	5.4 -
Critical Hdwy Stg 2	-	-	-	-	5.4 -
Follow-up Hdwy	2.2	-	-	-	3.5 3.3
Pot Cap-1 Maneuver	1635	-	-	-	1027 1090
Stage 1	-	-	-	-	1028 -
Stage 2	-	-	-	-	- -
Platoon blocked, %		-	-	-	
Mov Cap-1 Maneuver	1635	-	-	-	1027 1090
Mov Cap-2 Maneuver	-	-	-	-	1027 -
Stage 1	-	-	-	-	1028 -
Stage 2	-	-	-	-	- -

Approach	EB	WB	SB
HCM Control Delay, s	0	0	0
HCM LOS			A

Minor Lane/Major Mvmt	EBL	EBT	WBT	WBR	SBLn1
Capacity (veh/h)	1635	-	-	-	-
HCM Lane V/C Ratio	-	-	-	-	-
HCM Control Delay (s)	0	-	-	-	0
HCM Lane LOS	A	-	-	-	A
HCM 95th %tile Q(veh)	0	-	-	-	-

HCM 6th Signalized Intersection Summary

4: Lena Rd & Central Ave

09/23/2021



Movement	EBL	EBT	EBR	WBL	WBT	WBR	NBL	NBT	NBR	SBL	SBT	SBR
Lane Configurations	↖	↗		↖	↗		↖	↗	↗	↖	↗	
Traffic Volume (veh/h)	14	214	21	36	304	16	44	55	63	20	41	13
Future Volume (veh/h)	14	214	21	36	304	16	44	55	63	20	41	13
Initial Q (Qb), veh	0	0	0	0	0	0	0	0	0	0	0	0
Ped-Bike Adj(A_pbT)	1.00		1.00	1.00		1.00	1.00		1.00	1.00		1.00
Parking Bus, Adj	1.00	1.00	1.00	1.00	1.00	1.00	1.00	1.00	1.00	1.00	1.00	1.00
Work Zone On Approach		No			No			No			No	
Adj Sat Flow, veh/h/ln	1700	1800	1800	1700	1800	1800	1700	1800	1800	1700	1800	1800
Adj Flow Rate, veh/h	16	246	24	41	349	18	51	63	72	23	47	15
Peak Hour Factor	0.87	0.87	0.87	0.87	0.87	0.87	0.87	0.87	0.87	0.87	0.87	0.87
Percent Heavy Veh, %	0	0	0	0	0	0	0	0	0	0	0	0
Cap, veh/h	192	394	38	248	562	29	696	856	725	277	613	187
Arrive On Green	0.02	0.12	0.12	0.06	0.17	0.17	0.27	0.48	0.48	0.04	0.24	0.24
Sat Flow, veh/h	1619	3150	305	1619	3309	170	1619	1800	1525	1619	2582	786
Grp Volume(v), veh/h	16	133	137	41	180	187	51	63	72	23	30	32
Grp Sat Flow(s),veh/h/ln	1619	1710	1745	1619	1710	1769	1619	1800	1525	1619	1710	1658
Q Serve(g_s), s	0.7	5.9	6.0	1.7	7.8	7.9	0.0	1.5	2.1	0.9	1.1	1.2
Cycle Q Clear(g_c), s	0.7	5.9	6.0	1.7	7.8	7.9	0.0	1.5	2.1	0.9	1.1	1.2
Prop In Lane	1.00		0.17	1.00		0.10	1.00		1.00	1.00		0.47
Lane Grp Cap(c), veh/h	192	214	218	248	290	300	696	856	725	277	406	394
V/C Ratio(X)	0.08	0.62	0.63	0.17	0.62	0.62	0.07	0.07	0.10	0.08	0.07	0.08
Avail Cap(c_a), veh/h	362	363	371	346	363	376	696	856	725	423	406	394
HCM Platoon Ratio	1.00	1.00	1.00	1.00	1.00	1.00	1.00	1.00	1.00	1.00	1.00	1.00
Upstream Filter(I)	1.00	1.00	1.00	1.00	1.00	1.00	1.00	1.00	1.00	1.00	1.00	1.00
Uniform Delay (d), s/veh	29.7	33.2	33.2	27.2	30.8	30.8	15.0	11.4	11.6	26.9	23.7	23.7
Incr Delay (d2), s/veh	0.2	2.9	3.0	0.3	2.1	2.1	0.0	0.2	0.3	0.1	0.4	0.4
Initial Q Delay(d3),s/veh	0.0	0.0	0.0	0.0	0.0	0.0	0.0	0.0	0.0	0.0	0.0	0.0
%ile BackOfQ(50%),veh/ln	0.3	2.5	2.6	0.6	3.2	3.3	0.5	0.6	0.7	0.4	0.5	0.5
Unsig. Movement Delay, s/veh												
LnGrp Delay(d),s/veh	29.8	36.1	36.2	27.5	33.0	32.9	15.0	11.6	11.8	27.0	24.0	24.1
LnGrp LOS	C	D	D	C	C	C	B	B	B	C	C	C
Approach Vol, veh/h		286			408			186				85
Approach Delay, s/veh		35.8			32.4			12.6				24.9
Approach LOS		D			C			B				C
Timer - Assigned Phs	1	2	3	4	5	6	7	8				
Phs Duration (G+Y+Rc), s	8.8	44.0	11.2	16.0	27.8	25.0	7.6	19.6				
Change Period (Y+Rc), s	4.0	4.0	4.0	4.0	4.0	4.0	4.0	4.0				
Max Green Setting (Gmax), s	12.0	21.0	12.0	19.0	12.0	21.0	12.0	19.0				
Max Q Clear Time (g_c+I1), s	2.9	4.1	3.7	8.0	2.0	3.2	2.7	9.9				
Green Ext Time (p_c), s	0.0	0.4	0.0	1.0	0.1	0.2	0.0	1.3				
Intersection Summary												
HCM 6th Ctrl Delay											28.9	
HCM 6th LOS											C	

HCM 6th TWSC
5: Lena Rd & Driveway 3

09/23/2021

Intersection						
Int Delay, s/veh	0					
Movement	EBL	EBR	NBL	NBT	SBT	SBR
Lane Configurations						
Traffic Vol, veh/h	0	0	0	0	0	0
Future Vol, veh/h	0	0	0	0	0	0
Conflicting Peds, #/hr	0	0	0	0	0	0
Sign Control	Stop	Stop	Free	Free	Free	Free
RT Channelized	-	None	-	None	-	None
Storage Length	0	-	100	-	-	-
Veh in Median Storage, #	0	-	-	0	0	-
Grade, %	0	-	-	0	0	-
Peak Hour Factor	92	92	92	92	92	92
Heavy Vehicles, %	0	0	0	0	0	0
Mvmt Flow	0	0	0	0	0	0

Major/Minor	Minor2	Major1	Major2			
Conflicting Flow All	1	1	1	0	-	0
Stage 1	1	-	-	-	-	-
Stage 2	0	-	-	-	-	-
Critical Hdwy	6.8	6.9	4.1	-	-	-
Critical Hdwy Stg 1	5.8	-	-	-	-	-
Critical Hdwy Stg 2	5.8	-	-	-	-	-
Follow-up Hdwy	3.5	3.3	2.2	-	-	-
Pot Cap-1 Maneuver	1027	1089	1635	-	-	-
Stage 1	1027	-	-	-	-	-
Stage 2	-	-	-	-	-	-
Platoon blocked, %				-	-	-
Mov Cap-1 Maneuver	1027	1089	1635	-	-	-
Mov Cap-2 Maneuver	937	-	-	-	-	-
Stage 1	1027	-	-	-	-	-
Stage 2	-	-	-	-	-	-

Approach	EB	NB	SB
HCM Control Delay, s	0	0	0
HCM LOS	A		

Minor Lane/Major Mvmt	NBL	NBT	EBLn1	SBT	SBR
Capacity (veh/h)	1635	-	-	-	-
HCM Lane V/C Ratio	-	-	-	-	-
HCM Control Delay (s)	0	-	0	-	-
HCM Lane LOS	A	-	A	-	-
HCM 95th %tile Q(veh)	0	-	-	-	-

Intersection	
Intersection Delay, s/veh	8.4
Intersection LOS	A

Movement	EBL	EBT	EBR	WBL	WBT	WBR	NBL	NBT	NBR	SBL	SBT	SBR
Lane Configurations		↕			↕		↙	↕		↙	↕	
Traffic Vol, veh/h	8	13	10	42	15	4	7	122	55	8	85	10
Future Vol, veh/h	8	13	10	42	15	4	7	122	55	8	85	10
Peak Hour Factor	0.78	0.78	0.78	0.78	0.78	0.78	0.78	0.78	0.78	0.78	0.78	0.78
Heavy Vehicles, %	0	0	0	0	0	0	0	0	0	0	0	0
Mvmt Flow	10	17	13	54	19	5	9	156	71	10	109	13
Number of Lanes	0	1	0	0	1	0	1	2	0	1	2	0

Approach	EB	WB	NB	SB
Opposing Approach	WB	EB	SB	NB
Opposing Lanes	1	1	3	3
Conflicting Approach Left	SB	NB	EB	WB
Conflicting Lanes Left	3	3	1	1
Conflicting Approach Right	NB	SB	WB	EB
Conflicting Lanes Right	3	3	1	1
HCM Control Delay	8.4	9.2	8.3	8.2
HCM LOS	A	A	A	A

Lane	NBLn1	NBLn2	NBLn3	EBLn1	WBLn1	SBLn1	SBLn2	SBLn3
Vol Left, %	100%	0%	0%	26%	69%	100%	0%	0%
Vol Thru, %	0%	100%	43%	42%	25%	0%	100%	74%
Vol Right, %	0%	0%	57%	32%	7%	0%	0%	26%
Sign Control	Stop	Stop	Stop	Stop	Stop	Stop	Stop	Stop
Traffic Vol by Lane	7	81	96	31	61	8	57	38
LT Vol	7	0	0	8	42	8	0	0
Through Vol	0	81	41	13	15	0	57	28
RT Vol	0	0	55	10	4	0	0	10
Lane Flow Rate	9	104	123	40	78	10	73	49
Geometry Grp	7	7	7	7	7	7	7	7
Degree of Util (X)	0.014	0.144	0.155	0.059	0.123	0.016	0.102	0.066
Departure Headway (Hd)	5.46	4.957	4.553	5.302	5.642	5.543	5.04	4.857
Convergence, Y/N	Yes	Yes	Yes	Yes	Yes	Yes	Yes	Yes
Cap	656	724	789	675	635	646	711	737
Service Time	3.185	2.683	2.278	3.04	3.377	3.274	2.771	2.587
HCM Lane V/C Ratio	0.014	0.144	0.156	0.059	0.123	0.015	0.103	0.066
HCM Control Delay	8.3	8.5	8.1	8.4	9.2	8.4	8.3	7.9
HCM Lane LOS	A	A	A	A	A	A	A	A
HCM 95th-tile Q	0	0.5	0.5	0.2	0.4	0	0.3	0.2

HCM 6th TWSC
7: Orange Show Rd & Lena Rd

09/23/2021

Intersection						
Int Delay, s/veh	2.8					
Movement	EBL	EBT	WBT	WBR	SBL	SBR
Lane Configurations	↘	↑↑	↑↑		↘	↘
Traffic Vol, veh/h	145	606	547	37	24	112
Future Vol, veh/h	145	606	547	37	24	112
Conflicting Peds, #/hr	0	0	0	0	0	0
Sign Control	Free	Free	Free	Free	Stop	Stop
RT Channelized	-	None	-	None	-	None
Storage Length	145	-	-	-	0	0
Veh in Median Storage, #	-	0	0	-	0	-
Grade, %	-	0	0	-	0	-
Peak Hour Factor	81	81	81	81	81	81
Heavy Vehicles, %	0	0	0	0	0	0
Mvmt Flow	179	748	675	46	30	138

Major/Minor	Major1	Major2	Minor2		
Conflicting Flow All	721	0	-	0	1430
Stage 1	-	-	-	-	698
Stage 2	-	-	-	-	732
Critical Hdwy	4.1	-	-	-	6.8
Critical Hdwy Stg 1	-	-	-	-	5.8
Critical Hdwy Stg 2	-	-	-	-	5.8
Follow-up Hdwy	2.2	-	-	-	3.5
Pot Cap-1 Maneuver	890	-	-	-	128
Stage 1	-	-	-	-	460
Stage 2	-	-	-	-	442
Platoon blocked, %		-	-	-	
Mov Cap-1 Maneuver	890	-	-	-	102
Mov Cap-2 Maneuver	-	-	-	-	102
Stage 1	-	-	-	-	368
Stage 2	-	-	-	-	442

Approach	EB	WB	SB
HCM Control Delay, s	1.9	0	19.6
HCM LOS			C

Minor Lane/Major Mvmt	EBL	EBT	WBT	WBR	SBLn1	SBLn2
Capacity (veh/h)	890	-	-	-	102	641
HCM Lane V/C Ratio	0.201	-	-	-	0.288	0.216
HCM Control Delay (s)	10.1	-	-	-	54.1	12.2
HCM Lane LOS	B	-	-	-	F	B
HCM 95th %tile Q(veh)	0.7	-	-	-	1.1	0.8

HCM 6th TWSC
1: Foisy Street & Driveway 1

09/23/2021

Intersection						
Int Delay, s/veh	1.2					
Movement	WBL	WBR	NBT	NBR	SBL	SBT
Lane Configurations	W		T			T
Traffic Vol, veh/h	2	0	13	6	2	4
Future Vol, veh/h	2	0	13	6	2	4
Conflicting Peds, #/hr	0	0	0	0	0	0
Sign Control	Stop	Stop	Free	Free	Free	Free
RT Channelized	-	None	-	None	-	None
Storage Length	0	-	-	-	-	-
Veh in Median Storage, #	0	-	0	-	-	0
Grade, %	0	-	0	-	-	0
Peak Hour Factor	92	92	92	92	92	92
Heavy Vehicles, %	0	0	0	0	0	0
Mvmt Flow	2	0	14	7	2	4

Major/Minor	Minor1	Major1	Major2			
Conflicting Flow All	26	18	0	0	21	0
Stage 1	18	-	-	-	-	-
Stage 2	8	-	-	-	-	-
Critical Hdwy	6.4	6.2	-	-	4.1	-
Critical Hdwy Stg 1	5.4	-	-	-	-	-
Critical Hdwy Stg 2	5.4	-	-	-	-	-
Follow-up Hdwy	3.5	3.3	-	-	2.2	-
Pot Cap-1 Maneuver	995	1066	-	-	1608	-
Stage 1	1010	-	-	-	-	-
Stage 2	1020	-	-	-	-	-
Platoon blocked, %			-	-		-
Mov Cap-1 Maneuver	994	1066	-	-	1608	-
Mov Cap-2 Maneuver	994	-	-	-	-	-
Stage 1	1010	-	-	-	-	-
Stage 2	1019	-	-	-	-	-

Approach	WB	NB	SB
HCM Control Delay, s	8.6	0	2.4
HCM LOS	A		

Minor Lane/Major Mvmt	NBT	NBRWBLn1	SBL	SBT
Capacity (veh/h)	-	-	994	1608
HCM Lane V/C Ratio	-	-	0.002	0.001
HCM Control Delay (s)	-	-	8.6	7.2
HCM Lane LOS	-	-	A	A
HCM 95th %tile Q(veh)	-	-	0	0

HCM 6th TWSC
2: Norman Rd & Foisy Street

09/23/2021

Intersection						
Int Delay, s/veh	2.5					
Movement	EBL	EBT	WBT	WBR	SBL	SBR
Lane Configurations		↕	↕		↕	
Traffic Vol, veh/h	16	16	26	3	1	5
Future Vol, veh/h	16	16	26	3	1	5
Conflicting Peds, #/hr	0	0	0	0	0	0
Sign Control	Free	Free	Free	Free	Stop	Stop
RT Channelized	-	None	-	None	-	None
Storage Length	-	-	-	-	0	-
Veh in Median Storage, #	-	0	0	-	0	-
Grade, %	-	0	0	-	0	-
Peak Hour Factor	92	92	92	92	92	92
Heavy Vehicles, %	0	0	0	0	0	0
Mvmt Flow	17	17	28	3	1	5

Major/Minor	Major1	Major2	Minor2		
Conflicting Flow All	31	0	-	0	81 30
Stage 1	-	-	-	-	30 -
Stage 2	-	-	-	-	51 -
Critical Hdwy	4.1	-	-	-	6.4 6.2
Critical Hdwy Stg 1	-	-	-	-	5.4 -
Critical Hdwy Stg 2	-	-	-	-	5.4 -
Follow-up Hdwy	2.2	-	-	-	3.5 3.3
Pot Cap-1 Maneuver	1595	-	-	-	926 1050
Stage 1	-	-	-	-	998 -
Stage 2	-	-	-	-	977 -
Platoon blocked, %		-	-	-	
Mov Cap-1 Maneuver	1595	-	-	-	916 1050
Mov Cap-2 Maneuver	-	-	-	-	916 -
Stage 1	-	-	-	-	987 -
Stage 2	-	-	-	-	977 -

Approach	EB	WB	SB
HCM Control Delay, s	3.6	0	8.5
HCM LOS			A

Minor Lane/Major Mvmt	EBL	EBT	WBT	WBR	SBLn1
Capacity (veh/h)	1595	-	-	-	1025
HCM Lane V/C Ratio	0.011	-	-	-	0.006
HCM Control Delay (s)	7.3	0	-	-	8.5
HCM Lane LOS	A	A	-	-	A
HCM 95th %tile Q(veh)	0	-	-	-	0

HCM 6th TWSC
3: Norman Rd & Driveway 2

09/23/2021

Intersection						
Int Delay, s/veh	0.3					
Movement	EBL	EBT	WBT	WBR	SBL	SBR
Lane Configurations		↕	↕		↕	
Traffic Vol, veh/h	2	15	29	1	0	0
Future Vol, veh/h	2	15	29	1	0	0
Conflicting Peds, #/hr	0	0	0	0	0	0
Sign Control	Free	Free	Free	Free	Stop	Stop
RT Channelized	-	None	-	None	-	None
Storage Length	-	-	-	-	0	-
Veh in Median Storage, #	-	0	0	-	0	-
Grade, %	-	0	0	-	0	-
Peak Hour Factor	92	92	92	92	92	92
Heavy Vehicles, %	0	0	0	0	0	0
Mvmt Flow	2	16	32	1	0	0

Major/Minor	Major1	Major2	Minor2		
Conflicting Flow All	33	0	-	0	53 33
Stage 1	-	-	-	-	33 -
Stage 2	-	-	-	-	20 -
Critical Hdwy	4.1	-	-	-	6.4 6.2
Critical Hdwy Stg 1	-	-	-	-	5.4 -
Critical Hdwy Stg 2	-	-	-	-	5.4 -
Follow-up Hdwy	2.2	-	-	-	3.5 3.3
Pot Cap-1 Maneuver	1592	-	-	-	960 1046
Stage 1	-	-	-	-	995 -
Stage 2	-	-	-	-	1008 -
Platoon blocked, %		-	-	-	
Mov Cap-1 Maneuver	1592	-	-	-	959 1046
Mov Cap-2 Maneuver	-	-	-	-	959 -
Stage 1	-	-	-	-	994 -
Stage 2	-	-	-	-	1008 -























Approach	EB	WB	SB
HCM Control Delay, s	0.9	0	0
HCM LOS			A

Minor Lane/Major Mvmt	EBL	EBT	WBT	WBR	SBLn1
Capacity (veh/h)	1592	-	-	-	-
HCM Lane V/C Ratio	0.001	-	-	-	-
HCM Control Delay (s)	7.3	0	-	-	0
HCM Lane LOS	A	A	-	-	A
HCM 95th %tile Q(veh)	0	-	-	-	-

HCM 6th Signalized Intersection Summary

4: Lena Rd & Central Ave

09/23/2021

												
Movement	EBL	EBT	EBR	WBL	WBT	WBR	NBL	NBT	NBR	SBL	SBT	SBR
Lane Configurations												
Traffic Volume (veh/h)	11	193	17	42	221	16	36	39	89	17	17	13
Future Volume (veh/h)	11	193	17	42	221	16	36	39	89	17	17	13
Initial Q (Qb), veh	0	0	0	0	0	0	0	0	0	0	0	0
Ped-Bike Adj(A_pbT)	1.00		1.00	1.00		1.00	1.00		1.00	1.00		1.00
Parking Bus, Adj	1.00	1.00	1.00	1.00	1.00	1.00	1.00	1.00	1.00	1.00	1.00	1.00
Work Zone On Approach		No			No			No			No	
Adj Sat Flow, veh/h/ln	1700	1800	1800	1700	1800	1800	1700	1800	1800	1700	1800	1800
Adj Flow Rate, veh/h	11	197	17	43	226	16	37	40	91	17	17	13
Peak Hour Factor	0.98	0.98	0.98	0.98	0.98	0.98	0.98	0.98	0.98	0.98	0.98	0.98
Percent Heavy Veh, %	0	0	0	0	0	0	0	0	0	0	0	0
Cap, veh/h	237	399	34	274	599	42	713	874	741	281	462	315
Arrive On Green	0.01	0.12	0.12	0.07	0.18	0.18	0.27	0.49	0.49	0.02	0.24	0.24
Sat Flow, veh/h	1619	3188	273	1619	3241	228	1619	1800	1525	1619	1946	1325
Grp Volume(v), veh/h	11	105	109	43	119	123	37	40	91	17	15	15
Grp Sat Flow(s),veh/h/ln	1619	1710	1751	1619	1710	1759	1619	1800	1525	1619	1710	1561
Q Serve(g_s), s	0.5	4.6	4.7	1.7	4.9	4.9	0.0	0.9	2.6	0.7	0.5	0.6
Cycle Q Clear(g_c), s	0.5	4.6	4.7	1.7	4.9	4.9	0.0	0.9	2.6	0.7	0.5	0.6
Prop In Lane	1.00		0.16	1.00		0.13	1.00		1.00	1.00		0.85
Lane Grp Cap(c), veh/h	237	214	219	274	316	325	713	874	741	281	406	371
V/C Ratio(X)	0.05	0.49	0.50	0.16	0.38	0.38	0.05	0.05	0.12	0.06	0.04	0.04
Avail Cap(c_a), veh/h	427	363	372	367	363	374	713	874	741	448	406	371
HCM Platoon Ratio	1.00	1.00	1.00	1.00	1.00	1.00	1.00	1.00	1.00	1.00	1.00	1.00
Upstream Filter(I)	1.00	1.00	1.00	1.00	1.00	1.00	1.00	1.00	1.00	1.00	1.00	1.00
Uniform Delay (d), s/veh	30.3	32.6	32.7	25.5	28.6	28.6	14.3	10.8	11.3	26.7	23.5	23.5
Incr Delay (d2), s/veh	0.1	1.7	1.8	0.3	0.7	0.7	0.0	0.1	0.3	0.1	0.2	0.2
Initial Q Delay(d3),s/veh	0.0	0.0	0.0	0.0	0.0	0.0	0.0	0.0	0.0	0.0	0.0	0.0
%ile BackOfQ(50%),veh/ln	0.2	1.9	2.0	0.6	1.9	2.0	0.4	0.4	0.9	0.3	0.2	0.2
Unsig. Movement Delay, s/veh												
LnGrp Delay(d),s/veh	30.4	34.4	34.4	25.7	29.3	29.3	14.3	10.9	11.6	26.8	23.6	23.7
LnGrp LOS	C	C	C	C	C	C	B	B	B	C	C	C
Approach Vol, veh/h		225			285			168			47	
Approach Delay, s/veh		34.2			28.8			12.0			24.8	
Approach LOS		C			C			B			C	
Timer - Assigned Phs	1	2	3	4	5	6	7	8				
Phs Duration (G+Y+Rc), s	7.8	44.8	11.4	16.0	27.6	25.0	6.6	20.8				
Change Period (Y+Rc), s	4.0	4.0	4.0	4.0	4.0	4.0	4.0	4.0				
Max Green Setting (Gmax), s	12.0	21.0	12.0	19.0	12.0	21.0	12.0	19.0				
Max Q Clear Time (g_c+I1), s	2.7	4.6	3.7	6.7	2.0	2.6	2.5	6.9				
Green Ext Time (p_c), s	0.0	0.4	0.0	0.8	0.0	0.1	0.0	0.9				
Intersection Summary												
HCM 6th Ctrl Delay				26.3								
HCM 6th LOS				C								

HCM 6th TWSC
5: Lena Rd & Driveway 3

09/23/2021

Intersection						
Int Delay, s/veh	0.4					
Movement	EBL	EBR	NBL	NBT	SBT	SBR
Lane Configurations	⤵		⤵	↑↑	↑↑	
Traffic Vol, veh/h	5	2	3	120	95	6
Future Vol, veh/h	5	2	3	120	95	6
Conflicting Peds, #/hr	0	0	0	0	0	0
Sign Control	Stop	Stop	Free	Free	Free	Free
RT Channelized	-	None	-	None	-	None
Storage Length	0	-	100	-	-	-
Veh in Median Storage, #	0	-	-	0	0	-
Grade, %	0	-	-	0	0	-
Peak Hour Factor	92	92	92	92	92	92
Heavy Vehicles, %	0	0	0	0	0	0
Mvmt Flow	5	2	3	130	103	7

Major/Minor	Minor2	Major1	Major2			
Conflicting Flow All	178	55	110	0	-	0
Stage 1	107	-	-	-	-	-
Stage 2	71	-	-	-	-	-
Critical Hdwy	6.8	6.9	4.1	-	-	-
Critical Hdwy Stg 1	5.8	-	-	-	-	-
Critical Hdwy Stg 2	5.8	-	-	-	-	-
Follow-up Hdwy	3.5	3.3	2.2	-	-	-
Pot Cap-1 Maneuver	800	1007	1493	-	-	-
Stage 1	912	-	-	-	-	-
Stage 2	949	-	-	-	-	-
Platoon blocked, %				-	-	-
Mov Cap-1 Maneuver	798	1007	1493	-	-	-
Mov Cap-2 Maneuver	787	-	-	-	-	-
Stage 1	910	-	-	-	-	-
Stage 2	949	-	-	-	-	-

Approach	EB	NB	SB
HCM Control Delay, s	9.3	0.2	0
HCM LOS	A		

Minor Lane/Major Mvmt	NBL	NBT	EBLn1	SBT	SBR
Capacity (veh/h)	1493	-	839	-	-
HCM Lane V/C Ratio	0.002	-	0.009	-	-
HCM Control Delay (s)	7.4	-	9.3	-	-
HCM Lane LOS	A	-	A	-	-
HCM 95th %tile Q(veh)	0	-	0	-	-

Intersection	
Intersection Delay, s/veh	8.4
Intersection LOS	A

Movement	EBL	EBT	EBR	WBL	WBT	WBR	NBL	NBT	NBR	SBL	SBT	SBR
Lane Configurations		↕			↕		↕	↕		↕	↕	
Traffic Vol, veh/h	8	6	3	47	3	6	12	113	39	6	77	7
Future Vol, veh/h	8	6	3	47	3	6	12	113	39	6	77	7
Peak Hour Factor	0.72	0.72	0.72	0.72	0.72	0.72	0.72	0.72	0.72	0.72	0.72	0.72
Heavy Vehicles, %	0	0	0	0	0	0	0	0	0	0	0	0
Mvmt Flow	11	8	4	65	4	8	17	157	54	8	107	10
Number of Lanes	0	1	0	0	1	0	1	2	0	1	2	0

Approach	EB	WB	NB	SB
Opposing Approach	WB	EB	SB	NB
Opposing Lanes	1	1	3	3
Conflicting Approach Left	SB	NB	EB	WB
Conflicting Lanes Left	3	3	1	1
Conflicting Approach Right	NB	SB	WB	EB
Conflicting Lanes Right	3	3	1	1
HCM Control Delay	8.4	9.2	8.2	8.2
HCM LOS	A	A	A	A

Lane	NBLn1	NBLn2	NBLn3	EBLn1	WBLn1	SBLn1	SBLn2	SBLn3
Vol Left, %	100%	0%	0%	47%	84%	100%	0%	0%
Vol Thru, %	0%	100%	49%	35%	5%	0%	100%	79%
Vol Right, %	0%	0%	51%	18%	11%	0%	0%	21%
Sign Control	Stop	Stop	Stop	Stop	Stop	Stop	Stop	Stop
Traffic Vol by Lane	12	75	77	17	56	6	51	33
LT Vol	12	0	0	8	47	6	0	0
Through Vol	0	75	38	6	3	0	51	26
RT Vol	0	0	39	3	6	0	0	7
Lane Flow Rate	17	105	106	24	78	8	71	45
Geometry Grp	7	7	7	7	7	7	7	7
Degree of Util (X)	0.025	0.143	0.135	0.036	0.122	0.013	0.099	0.061
Departure Headway (Hd)	5.409	4.906	4.549	5.478	5.639	5.493	4.99	4.84
Convergence, Y/N	Yes	Yes	Yes	Yes	Yes	Yes	Yes	Yes
Cap	663	732	790	654	636	653	719	741
Service Time	3.128	2.626	2.268	3.212	3.369	3.215	2.713	2.562
HCM Lane V/C Ratio	0.026	0.143	0.134	0.037	0.123	0.012	0.099	0.061
HCM Control Delay	8.3	8.4	8	8.4	9.2	8.3	8.3	7.9
HCM Lane LOS	A	A	A	A	A	A	A	A
HCM 95th-tile Q	0.1	0.5	0.5	0.1	0.4	0	0.3	0.2

HCM 6th TWSC
7: Orange Show Rd & Lena Rd

09/23/2021

Intersection						
Int Delay, s/veh	2.1					
Movement	EBL	EBT	WBT	WBR	SBL	SBR
Lane Configurations	↘	↑↑	↑↑		↘	↘
Traffic Vol, veh/h	160	423	374	30	11	55
Future Vol, veh/h	160	423	374	30	11	55
Conflicting Peds, #/hr	0	0	0	0	0	0
Sign Control	Free	Free	Free	Free	Stop	Stop
RT Channelized	-	None	-	None	-	None
Storage Length	145	-	-	-	0	0
Veh in Median Storage, #	-	0	0	-	0	-
Grade, %	-	0	0	-	0	-
Peak Hour Factor	87	87	87	87	87	87
Heavy Vehicles, %	0	0	0	0	0	0
Mvmt Flow	184	486	430	34	13	63

Major/Minor	Major1	Major2	Minor2		
Conflicting Flow All	464	0	-	0	1058
Stage 1	-	-	-	-	447
Stage 2	-	-	-	-	611
Critical Hdwy	4.1	-	-	-	6.8
Critical Hdwy Stg 1	-	-	-	-	5.8
Critical Hdwy Stg 2	-	-	-	-	5.8
Follow-up Hdwy	2.2	-	-	-	3.5
Pot Cap-1 Maneuver	1108	-	-	-	223
Stage 1	-	-	-	-	617
Stage 2	-	-	-	-	510
Platoon blocked, %		-	-	-	
Mov Cap-1 Maneuver	1108	-	-	-	186
Mov Cap-2 Maneuver	-	-	-	-	186
Stage 1	-	-	-	-	515
Stage 2	-	-	-	-	510

Approach	EB	WB	SB
HCM Control Delay, s	2.4	0	12.7
HCM LOS			B

Minor Lane/Major Mvmt	EBL	EBT	WBT	WBR	SBLn1	SBLn2
Capacity (veh/h)	1108	-	-	-	186	776
HCM Lane V/C Ratio	0.166	-	-	-	0.068	0.081
HCM Control Delay (s)	8.9	-	-	-	25.8	10.1
HCM Lane LOS	A	-	-	-	D	B
HCM 95th %tile Q(veh)	0.6	-	-	-	0.2	0.3

HCM 6th TWSC
1: Foisy Street & Driveway 1

09/23/2021

Intersection						
Int Delay, s/veh	3.1					
Movement	WBL	WBR	NBT	NBR	SBL	SBT
Lane Configurations	W		T			T
Traffic Vol, veh/h	6	2	7	1	0	6
Future Vol, veh/h	6	2	7	1	0	6
Conflicting Peds, #/hr	0	0	0	0	0	0
Sign Control	Stop	Stop	Free	Free	Free	Free
RT Channelized	-	None	-	None	-	None
Storage Length	0	-	-	-	-	-
Veh in Median Storage, #	0	-	0	-	-	0
Grade, %	0	-	0	-	-	0
Peak Hour Factor	92	92	92	92	92	92
Heavy Vehicles, %	0	0	0	0	0	0
Mvmt Flow	7	2	8	1	0	7

Major/Minor	Minor1	Major1	Major2			
Conflicting Flow All	16	9	0	0	9	0
Stage 1	9	-	-	-	-	-
Stage 2	7	-	-	-	-	-
Critical Hdwy	6.4	6.2	-	-	4.1	-
Critical Hdwy Stg 1	5.4	-	-	-	-	-
Critical Hdwy Stg 2	5.4	-	-	-	-	-
Follow-up Hdwy	3.5	3.3	-	-	2.2	-
Pot Cap-1 Maneuver	1008	1079	-	-	1624	-
Stage 1	1019	-	-	-	-	-
Stage 2	1021	-	-	-	-	-
Platoon blocked, %			-	-		-
Mov Cap-1 Maneuver	1008	1079	-	-	1624	-
Mov Cap-2 Maneuver	1008	-	-	-	-	-
Stage 1	1019	-	-	-	-	-
Stage 2	1021	-	-	-	-	-

Approach	WB	NB	SB
HCM Control Delay, s	8.5	0	0
HCM LOS	A		

Minor Lane/Major Mvmt	NBT	NBRWBLn1	SBL	SBT
Capacity (veh/h)	-	-	1025	1624
HCM Lane V/C Ratio	-	-	0.008	-
HCM Control Delay (s)	-	-	8.5	0
HCM Lane LOS	-	-	A	A
HCM 95th %tile Q(veh)	-	-	0	0

HCM 6th TWSC
2: Norman Rd & Foisy Street

09/23/2021

Intersection						
Int Delay, s/veh	1.7					
Movement	EBL	EBT	WBT	WBR	SBL	SBR
Lane Configurations		↕	↕		↕	
Traffic Vol, veh/h	6	32	35	2	5	7
Future Vol, veh/h	6	32	35	2	5	7
Conflicting Peds, #/hr	0	0	0	0	0	0
Sign Control	Free	Free	Free	Free	Stop	Stop
RT Channelized	-	None	-	None	-	None
Storage Length	-	-	-	-	0	-
Veh in Median Storage, #	-	0	0	-	0	-
Grade, %	-	0	0	-	0	-
Peak Hour Factor	92	92	92	92	92	92
Heavy Vehicles, %	0	0	0	0	0	0
Mvmt Flow	7	35	38	2	5	8

Major/Minor	Major1	Major2	Minor2		
Conflicting Flow All	40	0	-	0	88 39
Stage 1	-	-	-	-	39 -
Stage 2	-	-	-	-	49 -
Critical Hdwy	4.1	-	-	-	6.4 6.2
Critical Hdwy Stg 1	-	-	-	-	5.4 -
Critical Hdwy Stg 2	-	-	-	-	5.4 -
Follow-up Hdwy	2.2	-	-	-	3.5 3.3
Pot Cap-1 Maneuver	1583	-	-	-	918 1038
Stage 1	-	-	-	-	989 -
Stage 2	-	-	-	-	979 -
Platoon blocked, %		-	-	-	
Mov Cap-1 Maneuver	1583	-	-	-	913 1038
Mov Cap-2 Maneuver	-	-	-	-	913 -
Stage 1	-	-	-	-	984 -
Stage 2	-	-	-	-	979 -

Approach	EB	WB	SB
HCM Control Delay, s	1.2	0	8.7
HCM LOS			A

Minor Lane/Major Mvmt	EBL	EBT	WBT	WBR	SBLn1
Capacity (veh/h)	1583	-	-	-	982
HCM Lane V/C Ratio	0.004	-	-	-	0.013
HCM Control Delay (s)	7.3	0	-	-	8.7
HCM Lane LOS	A	A	-	-	A
HCM 95th %tile Q(veh)	0	-	-	-	0

HCM 6th TWSC
3: Norman Rd & Driveway 2

09/23/2021

Intersection						
Int Delay, s/veh	0.3					
Movement	EBL	EBT	WBT	WBR	SBL	SBR
Lane Configurations		↕	↕		↕	
Traffic Vol, veh/h	0	38	36	0	1	2
Future Vol, veh/h	0	38	36	0	1	2
Conflicting Peds, #/hr	0	0	0	0	0	0
Sign Control	Free	Free	Free	Free	Stop	Stop
RT Channelized	-	None	-	None	-	None
Storage Length	-	-	-	-	0	-
Veh in Median Storage, #	-	0	0	-	0	-
Grade, %	-	0	0	-	0	-
Peak Hour Factor	92	92	92	92	92	92
Heavy Vehicles, %	0	0	0	0	0	0
Mvmt Flow	0	41	39	0	1	2

Major/Minor	Major1	Major2	Minor2		
Conflicting Flow All	39	0	-	0	80 39
Stage 1	-	-	-	-	39 -
Stage 2	-	-	-	-	41 -
Critical Hdwy	4.1	-	-	-	6.4 6.2
Critical Hdwy Stg 1	-	-	-	-	5.4 -
Critical Hdwy Stg 2	-	-	-	-	5.4 -
Follow-up Hdwy	2.2	-	-	-	3.5 3.3
Pot Cap-1 Maneuver	1584	-	-	-	927 1038
Stage 1	-	-	-	-	989 -
Stage 2	-	-	-	-	987 -
Platoon blocked, %		-	-	-	
Mov Cap-1 Maneuver	1584	-	-	-	927 1038
Mov Cap-2 Maneuver	-	-	-	-	927 -
Stage 1	-	-	-	-	989 -
Stage 2	-	-	-	-	987 -























Approach	EB	WB	SB
HCM Control Delay, s	0	0	8.6
HCM LOS			A

Minor Lane/Major Mvmt	EBL	EBT	WBT	WBR	SBLn1
Capacity (veh/h)	1584	-	-	-	998
HCM Lane V/C Ratio	-	-	-	-	0.003
HCM Control Delay (s)	0	-	-	-	8.6
HCM Lane LOS	A	-	-	-	A
HCM 95th %tile Q(veh)	0	-	-	-	0

HCM 6th Signalized Intersection Summary

4: Lena Rd & Central Ave

09/23/2021

												
Movement	EBL	EBT	EBR	WBL	WBT	WBR	NBL	NBT	NBR	SBL	SBT	SBR
Lane Configurations												
Traffic Volume (veh/h)	14	214	23	36	304	16	48	55	64	20	41	13
Future Volume (veh/h)	14	214	23	36	304	16	48	55	64	20	41	13
Initial Q (Qb), veh	0	0	0	0	0	0	0	0	0	0	0	0
Ped-Bike Adj(A_pbT)	1.00		1.00	1.00		1.00	1.00		1.00	1.00		1.00
Parking Bus, Adj	1.00	1.00	1.00	1.00	1.00	1.00	1.00	1.00	1.00	1.00	1.00	1.00
Work Zone On Approach		No			No			No			No	
Adj Sat Flow, veh/h/ln	1700	1800	1800	1700	1800	1800	1700	1800	1800	1700	1800	1800
Adj Flow Rate, veh/h	16	246	26	41	349	18	55	63	74	23	47	15
Peak Hour Factor	0.87	0.87	0.87	0.87	0.87	0.87	0.87	0.87	0.87	0.87	0.87	0.87
Percent Heavy Veh, %	0	0	0	0	0	0	0	0	0	0	0	0
Cap, veh/h	192	391	41	247	562	29	818	428	362	784	613	187
Arrive On Green	0.02	0.12	0.12	0.06	0.17	0.17	0.27	0.24	0.24	0.27	0.24	0.24
Sat Flow, veh/h	1619	3124	327	1619	3309	170	1619	1800	1525	1619	2582	786
Grp Volume(v), veh/h	16	134	138	41	180	187	55	63	74	23	30	32
Grp Sat Flow(s),veh/h/ln	1619	1710	1741	1619	1710	1769	1619	1800	1525	1619	1710	1658
Q Serve(g_s), s	0.7	5.9	6.0	1.7	7.8	7.9	0.0	2.2	2.4	0.0	1.1	1.2
Cycle Q Clear(g_c), s	0.7	5.9	6.0	1.7	7.8	7.9	0.0	2.2	2.4	0.0	1.1	1.2
Prop In Lane	1.00		0.19	1.00		0.10	1.00		1.00	1.00		0.47
Lane Grp Cap(c), veh/h	192	214	218	247	290	300	818	428	362	784	406	394
V/C Ratio(X)	0.08	0.63	0.64	0.17	0.62	0.62	0.07	0.15	0.20	0.03	0.07	0.08
Avail Cap(c_a), veh/h	362	363	370	345	363	376	818	428	362	784	406	394
HCM Platoon Ratio	1.00	1.00	1.00	1.00	1.00	1.00	1.00	1.00	1.00	1.00	1.00	1.00
Upstream Filter(I)	1.00	1.00	1.00	1.00	1.00	1.00	1.00	1.00	1.00	1.00	1.00	1.00
Uniform Delay (d), s/veh	29.7	33.2	33.3	27.2	30.8	30.8	10.6	24.1	15.0	10.9	23.7	23.7
Incr Delay (d2), s/veh	0.2	3.0	3.1	0.3	2.1	2.1	0.0	0.7	1.3	0.0	0.4	0.4
Initial Q Delay(d3),s/veh	0.0	0.0	0.0	0.0	0.0	0.0	0.0	0.0	0.0	0.0	0.0	0.0
%ile BackOfQ(50%),veh/ln	0.3	2.5	2.6	0.6	3.2	3.3	0.5	1.0	1.2	0.2	0.5	0.5
Unsig. Movement Delay, s/veh												
LnGrp Delay(d),s/veh	29.8	36.2	36.3	27.5	33.0	32.9	10.7	24.8	16.3	10.9	24.0	24.1
LnGrp LOS	C	D	D	C	C	C	B	C	B	B	C	C
Approach Vol, veh/h		288			408			192				85
Approach Delay, s/veh		35.9			32.4			17.5				20.5
Approach LOS		D			C			B				C
Timer - Assigned Phs	1	2	3	4	5	6	7	8				
Phs Duration (G+Y+Rc), s	27.8	25.0	11.2	16.0	27.8	25.0	7.6	19.6				
Change Period (Y+Rc), s	4.0	4.0	4.0	4.0	4.0	4.0	4.0	4.0				
Max Green Setting (Gmax), s	12.0	21.0	12.0	19.0	12.0	21.0	12.0	19.0				
Max Q Clear Time (g_c+I1), s	2.0	4.4	3.7	8.0	2.0	3.2	2.7	9.9				
Green Ext Time (p_c), s	0.0	0.4	0.0	1.0	0.1	0.2	0.0	1.3				
Intersection Summary												
HCM 6th Ctrl Delay			29.5									
HCM 6th LOS			C									

HCM 6th TWSC
5: Lena Rd & Driveway 3

09/23/2021

Intersection						
Int Delay, s/veh	0.4					
Movement	EBL	EBR	NBL	NBT	SBT	SBR
Lane Configurations	Y		Y	↑↑	↑↑	
Traffic Vol, veh/h	5	3	1	139	100	2
Future Vol, veh/h	5	3	1	139	100	2
Conflicting Peds, #/hr	0	0	0	0	0	0
Sign Control	Stop	Stop	Free	Free	Free	Free
RT Channelized	-	None	-	None	-	None
Storage Length	0	-	100	-	-	-
Veh in Median Storage, #	1	-	-	0	0	-
Grade, %	0	-	-	0	0	-
Peak Hour Factor	92	92	92	92	92	92
Heavy Vehicles, %	0	0	0	0	0	0
Mvmt Flow	5	3	1	151	109	2

Major/Minor	Minor2	Major1		Major2	
Conflicting Flow All	188	56	111	0	0
Stage 1	110	-	-	-	-
Stage 2	78	-	-	-	-
Critical Hdwy	6.8	6.9	4.1	-	-
Critical Hdwy Stg 1	5.8	-	-	-	-
Critical Hdwy Stg 2	5.8	-	-	-	-
Follow-up Hdwy	3.5	3.3	2.2	-	-
Pot Cap-1 Maneuver	789	1005	1492	-	-
Stage 1	908	-	-	-	-
Stage 2	942	-	-	-	-
Platoon blocked, %				-	-
Mov Cap-1 Maneuver	788	1005	1492	-	-
Mov Cap-2 Maneuver	781	-	-	-	-
Stage 1	907	-	-	-	-
Stage 2	942	-	-	-	-

Approach	EB	NB	SB
HCM Control Delay, s	9.3	0.1	0
HCM LOS	A		

Minor Lane/Major Mvmt	NBL	NBT	EBLn1	SBT	SBR
Capacity (veh/h)	1492	-	852	-	-
HCM Lane V/C Ratio	0.001	-	0.01	-	-
HCM Control Delay (s)	7.4	-	9.3	-	-
HCM Lane LOS	A	-	A	-	-
HCM 95th %tile Q(veh)	0	-	0	-	-

Intersection	
Intersection Delay, s/veh	8.5
Intersection LOS	A

Movement	EBL	EBT	EBR	WBL	WBT	WBR	NBL	NBT	NBR	SBL	SBT	SBR
Lane Configurations		↕			↕		↙	↕		↙	↕	
Traffic Vol, veh/h	8	14	12	42	15	4	7	123	55	8	88	10
Future Vol, veh/h	8	14	12	42	15	4	7	123	55	8	88	10
Peak Hour Factor	0.78	0.78	0.78	0.78	0.78	0.78	0.78	0.78	0.78	0.78	0.78	0.78
Heavy Vehicles, %	0	0	0	0	0	0	0	0	0	0	0	0
Mvmt Flow	10	18	15	54	19	5	9	158	71	10	113	13
Number of Lanes	0	1	0	0	1	0	1	2	0	1	2	0

Approach	EB	WB	NB	SB
Opposing Approach	WB	EB	SB	NB
Opposing Lanes	1	1	3	3
Conflicting Approach Left	SB	NB	EB	WB
Conflicting Lanes Left	3	3	1	1
Conflicting Approach Right	NB	SB	WB	EB
Conflicting Lanes Right	3	3	1	1
HCM Control Delay	8.4	9.2	8.3	8.3
HCM LOS	A	A	A	A

Lane	NBLn1	NBLn2	NBLn3	EBLn1	WBLn1	SBLn1	SBLn2	SBLn3
Vol Left, %	100%	0%	0%	24%	69%	100%	0%	0%
Vol Thru, %	0%	100%	43%	41%	25%	0%	100%	75%
Vol Right, %	0%	0%	57%	35%	7%	0%	0%	25%
Sign Control	Stop	Stop	Stop	Stop	Stop	Stop	Stop	Stop
Traffic Vol by Lane	7	82	96	34	61	8	59	39
LT Vol	7	0	0	8	42	8	0	0
Through Vol	0	82	41	14	15	0	59	29
RT Vol	0	0	55	12	4	0	0	10
Lane Flow Rate	9	105	123	44	78	10	75	50
Geometry Grp	7	7	7	7	7	7	7	7
Degree of Util (X)	0.014	0.145	0.156	0.064	0.123	0.016	0.106	0.068
Departure Headway (Hd)	5.473	4.97	4.567	5.281	5.658	5.556	5.053	4.874
Convergence, Y/N	Yes	Yes	Yes	Yes	Yes	Yes	Yes	Yes
Cap	655	722	785	677	633	645	709	735
Service Time	3.2	2.697	2.294	3.02	3.395	3.286	2.783	2.604
HCM Lane V/C Ratio	0.014	0.145	0.157	0.065	0.123	0.016	0.106	0.068
HCM Control Delay	8.3	8.5	8.1	8.4	9.2	8.4	8.4	8
HCM Lane LOS	A	A	A	A	A	A	A	A
HCM 95th-tile Q	0	0.5	0.6	0.2	0.4	0	0.4	0.2

HCM 6th TWSC
7: Orange Show Rd & Lena Rd

09/23/2021

Intersection						
Int Delay, s/veh	2.9					
Movement	EBL	EBT	WBT	WBR	SBL	SBR
Lane Configurations	↘	↑↑	↑↑		↘	↘
Traffic Vol, veh/h	146	606	547	37	25	116
Future Vol, veh/h	146	606	547	37	25	116
Conflicting Peds, #/hr	0	0	0	0	0	0
Sign Control	Free	Free	Free	Free	Stop	Stop
RT Channelized	-	None	-	None	-	None
Storage Length	145	-	-	-	0	0
Veh in Median Storage, #	-	0	0	-	0	-
Grade, %	-	0	0	-	0	-
Peak Hour Factor	81	81	81	81	81	81
Heavy Vehicles, %	0	0	0	0	0	0
Mvmt Flow	180	748	675	46	31	143

Major/Minor	Major1	Major2	Minor2		
Conflicting Flow All	721	0	-	0	1432 361
Stage 1	-	-	-	-	698 -
Stage 2	-	-	-	-	734 -
Critical Hdwy	4.1	-	-	-	6.8 6.9
Critical Hdwy Stg 1	-	-	-	-	5.8 -
Critical Hdwy Stg 2	-	-	-	-	5.8 -
Follow-up Hdwy	2.2	-	-	-	3.5 3.3
Pot Cap-1 Maneuver	890	-	-	-	127 641
Stage 1	-	-	-	-	460 -
Stage 2	-	-	-	-	441 -
Platoon blocked, %		-	-	-	
Mov Cap-1 Maneuver	890	-	-	-	101 641
Mov Cap-2 Maneuver	-	-	-	-	101 -
Stage 1	-	-	-	-	367 -
Stage 2	-	-	-	-	441 -

Approach	EB	WB	SB
HCM Control Delay, s	2	0	19.9
HCM LOS			C

Minor Lane/Major Mvmt	EBL	EBT	WBT	WBR	SBLn1	SBLn2
Capacity (veh/h)	890	-	-	-	101	641
HCM Lane V/C Ratio	0.203	-	-	-	0.288	0.223
HCM Control Delay (s)	10.1	-	-	-	55.6	12.2
HCM Lane LOS	B	-	-	-	F	B
HCM 95th %tile Q(veh)	0.8	-	-	-	1.2	0.9

HCM 6th AWSC
7: Orange Show Rd & Lena Rd

09/23/2021

Intersection	
Intersection Delay, s/veh	11.7
Intersection LOS	B

Movement	EBL	EBT	WBT	WBR	SBL	SBR
Lane Configurations	↘	↑↑	↑↑		↘	↗
Traffic Vol, veh/h	160	423	374	30	11	55
Future Vol, veh/h	160	423	374	30	11	55
Peak Hour Factor	0.87	0.87	0.87	0.87	0.87	0.87
Heavy Vehicles, %	0	0	0	0	0	0
Mvmt Flow	184	486	430	34	13	63
Number of Lanes	1	2	2	0	1	1

Approach	EB	WB	SB
Opposing Approach	WB	EB	
Opposing Lanes	2	3	0
Conflicting Approach Left	SB		WB
Conflicting Lanes Left	2	0	2
Conflicting Approach Right		SB	EB
Conflicting Lanes Right	0	2	3
HCM Control Delay	10.9	13.1	10.3
HCM LOS	B	B	B

Lane	EBLn1	EBLn2	EBLn3	WBLn1	WBLn2	SBLn1	SBLn2
Vol Left, %	100%	0%	0%	0%	0%	100%	0%
Vol Thru, %	0%	100%	100%	100%	81%	0%	0%
Vol Right, %	0%	0%	0%	0%	19%	0%	100%
Sign Control	Stop	Stop	Stop	Stop	Stop	Stop	Stop
Traffic Vol by Lane	160	212	212	249	155	11	55
LT Vol	160	0	0	0	0	11	0
Through Vol	0	212	212	249	125	0	0
RT Vol	0	0	0	0	30	0	55
Lane Flow Rate	184	243	243	287	178	13	63
Geometry Grp	8	8	8	8	8	8	8
Degree of Util (X)	0.325	0.395	0.28	0.482	0.293	0.027	0.116
Departure Headway (Hd)	6.359	5.855	4.143	6.06	5.924	7.822	6.608
Convergence, Y/N	Yes	Yes	Yes	Yes	Yes	Yes	Yes
Cap	566	615	865	596	608	457	542
Service Time	4.088	3.584	1.872	3.79	3.653	5.573	4.359
HCM Lane V/C Ratio	0.325	0.395	0.281	0.482	0.293	0.028	0.116
HCM Control Delay	12.1	12.4	8.5	14.3	11.1	10.8	10.2
HCM Lane LOS	B	B	A	B	B	B	B
HCM 95th-tile Q	1.4	1.9	1.1	2.6	1.2	0.1	0.4

HCM 6th AWSC
7: Orange Show Rd & Lena Rd

09/23/2021

Intersection	
Intersection Delay, s/veh	26.4
Intersection LOS	D

Movement	EBL	EBT	WBT	WBR	SBL	SBR
Lane Configurations	↘	↑↑	↑↑		↘	↗
Traffic Vol, veh/h	146	606	547	37	25	116
Future Vol, veh/h	146	606	547	37	25	116
Peak Hour Factor	0.81	0.81	0.81	0.81	0.81	0.81
Heavy Vehicles, %	0	0	0	0	0	0
Mvmt Flow	180	748	675	46	31	143
Number of Lanes	1	2	2	0	1	1

Approach	EB	WB	SB
Opposing Approach	WB	EB	
Opposing Lanes	2	3	0
Conflicting Approach Left	SB		WB
Conflicting Lanes Left	2	0	2
Conflicting Approach Right		SB	EB
Conflicting Lanes Right	0	2	3
HCM Control Delay	20.2	37.1	14.7
HCM LOS	C	E	B

Lane	EBLn1	EBLn2	EBLn3	WBLn1	WBLn2	SBLn1	SBLn2
Vol Left, %	100%	0%	0%	0%	0%	100%	0%
Vol Thru, %	0%	100%	100%	100%	83%	0%	0%
Vol Right, %	0%	0%	0%	0%	17%	0%	100%
Sign Control	Stop	Stop	Stop	Stop	Stop	Stop	Stop
Traffic Vol by Lane	146	303	303	365	219	25	116
LT Vol	146	0	0	0	0	25	0
Through Vol	0	303	303	365	182	0	0
RT Vol	0	0	0	0	37	0	116
Lane Flow Rate	180	374	374	450	271	31	143
Geometry Grp	8	8	8	8	8	8	8
Degree of Util (X)	0.384	0.743	0.564	0.912	0.54	0.081	0.329
Departure Headway (Hd)	7.663	7.155	5.426	7.296	7.176	9.5	8.27
Convergence, Y/N	Yes	Yes	Yes	Yes	Yes	Yes	Yes
Cap	470	505	666	495	504	377	434
Service Time	5.404	4.896	3.166	5.043	4.923	7.272	6.041
HCM Lane V/C Ratio	0.383	0.741	0.562	0.909	0.538	0.082	0.329
HCM Control Delay	15.1	27.9	15	48.6	18.1	13.1	15.1
HCM Lane LOS	C	D	B	E	C	B	C
HCM 95th-tile Q	1.8	6.2	3.5	10.5	3.2	0.3	1.4

APPENDIX D: SBCTA LOW VMT AREA SCREENING TOOL

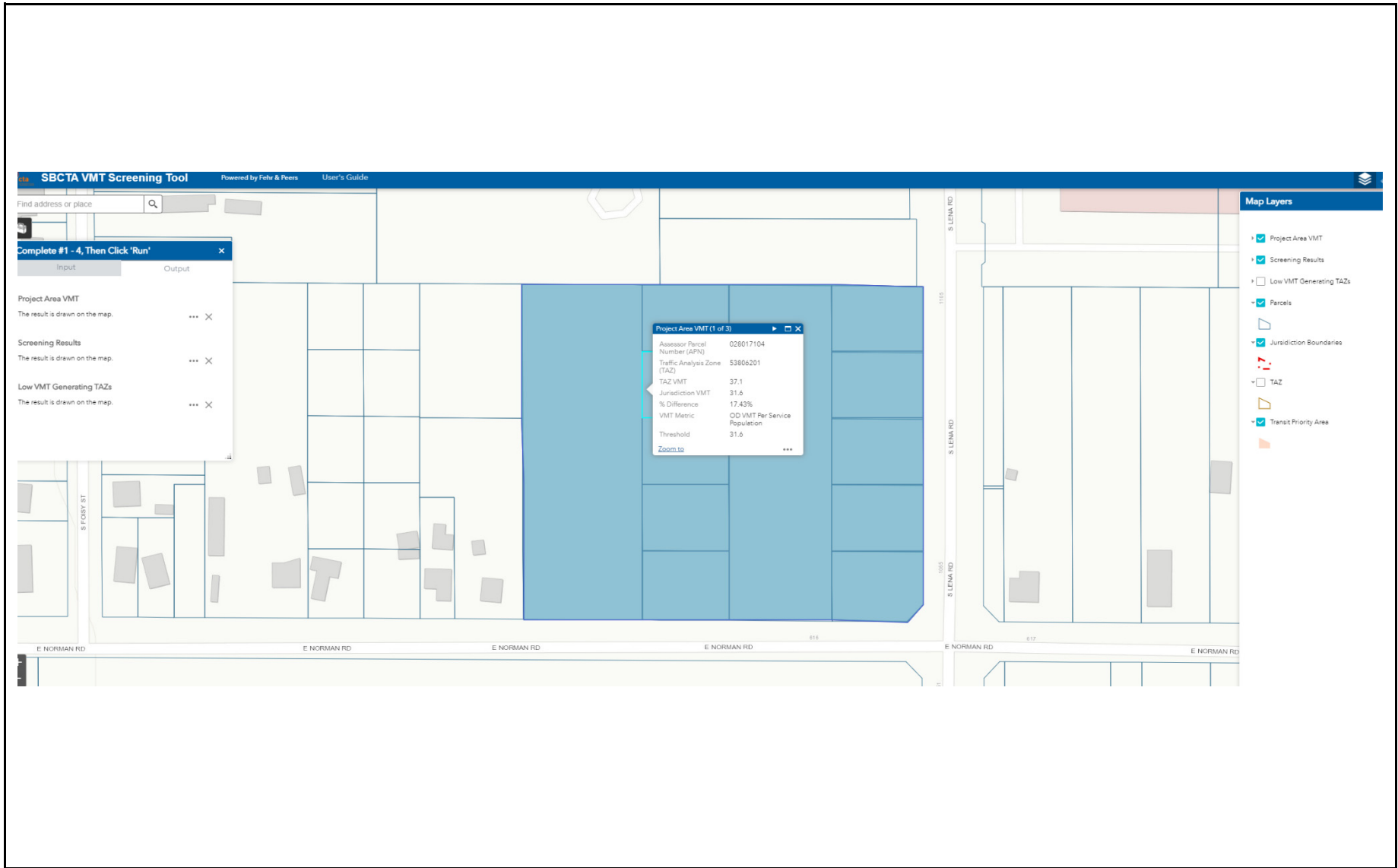

FIGURE D-1

Gateway South 8 Warehouse
SBCTA Low VMT Area Screening Tool (Baseline)

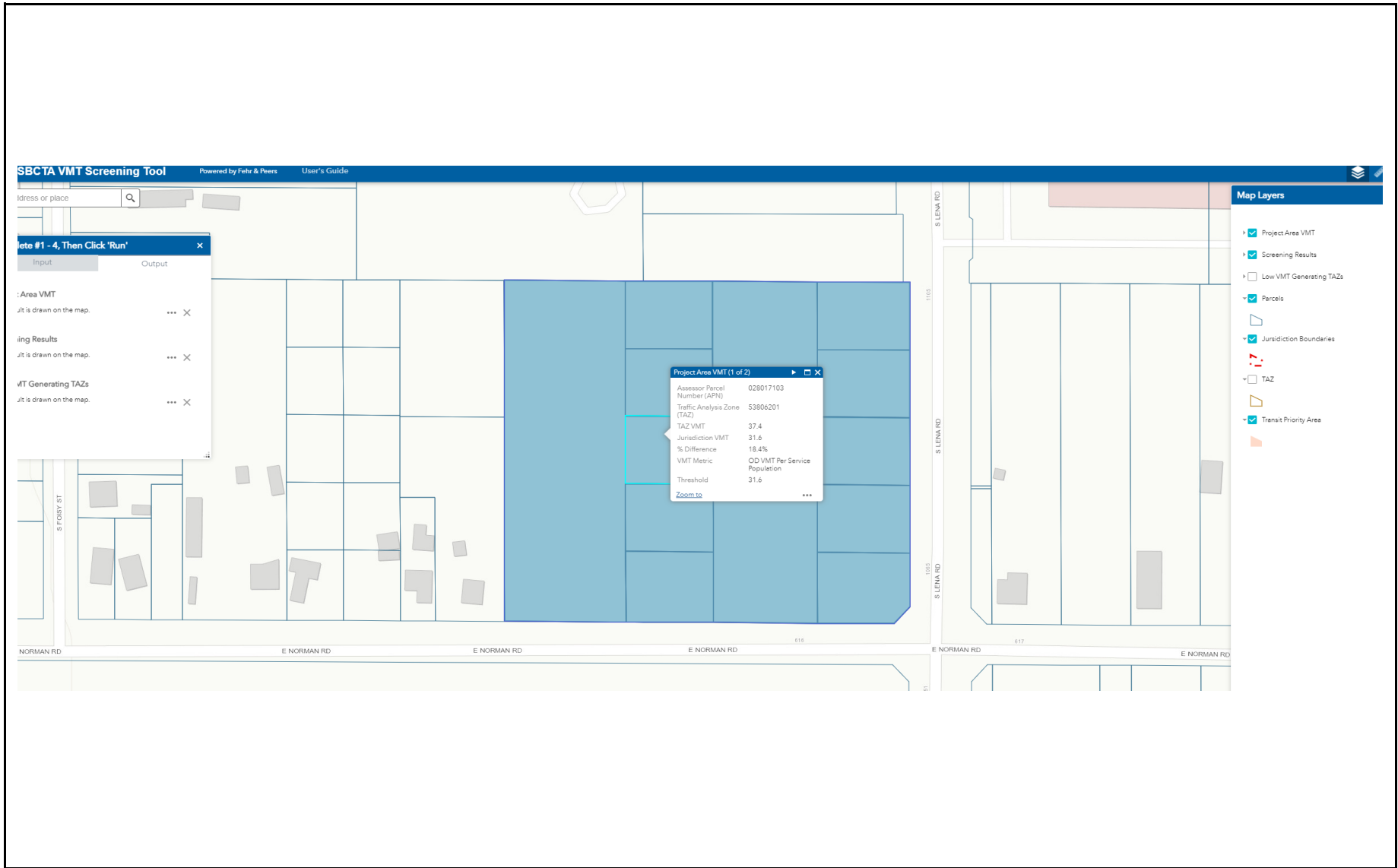

FIGURE D-2

Gateway South 8 Warehouse
SBCTA Low VMT Area Screening Tool (2040)

